

Omar Arias-Montez, President
John Carapiet, Vice President
Richard Snyder, Secretary

Catharine Benediktsson, Director
Tod Moody, Director

**NOTICE AND AGENDA
Regular Board Meeting
at Sanitary District No. 5 of Marin County
Thursday, October 17th, 2024**

5:00 P.M. REGULAR BOARD MEETING

Teleconference Location:

Director Richard Snyder 10 Pomander Walk Belvedere CA 94920	Director Catherine Benediktsson 2352 Mar East Street Tiburon CA 94920
---	---

PURSUANT TO THE RALPH M. BROWN ACT, ALL VOTES SHALL BE BY ROLL CALL DUE TO DIRECTOR SNYDER TELECONFERENCE FROM 10 Pomander Walk Belvedere CA 94920 & DIRECTOR BENEDIKTSSON FROM 2352 Mar East Street Tiburon CA 94920

ROLL CALL:

PUBLIC COMMENTS: The public is invited to address the Board on items that do not appear on the agenda and are within the subject matter jurisdiction of the Board. The Brown Act does not allow the Board to take action on any public comment. Please limit public comments to no more than three minutes.

DIRECTORS' COMMENTS AND/OR AGENDA REQUESTS:

CONSENT CALENDAR:

1. Approval of September 19th, 2024 Regular Board Meeting Minutes
2. Review and receive all electronic fund transfers (EFTs) and approve warrants from September 13th, 2024, through October 10th, 2024, (JP Morgan Chase Bank, check no.10810 through check no. 10868, all transactions totaling \$1,199,740.55) and receive September 2024 payroll, in the sum of \$131,678.46 (Rubio)
3. Receipt of Financial Reports through October 10, 2024 (Rubio)

MANAGEMENT REPORTS:

4. District Manager Summary Report (Rubio)

NEW BUSINESS:

5. Review of final Plan Set and Specifications regarding the 2025 Sewer Rehabilitation Project - prepared by Nute Engineers and authorize the District Manager to prepare project to go out to bid. –Action (Rubio)
6. Discussion regarding potential for adding bill pay as a payment option for the District through its current bank CHASE for paying vendors/contractors. -Discussion only (Rubio)

7. Review and discuss updated draft agreement with Mill Valley refuse for the transportation of the Districts Bio-Solids and authorize the District Manager to proceed with entering into a new agreement with Mill Valley Refuse for Bio-Solids deliveries to the Lystek Facility located in Fairfield CA and Redwood Landfill Located in Novato CA. -Action (Rubio)
8. Consideration to Cancel the Regular Board Meeting scheduled for November 21, 2024 and schedule a special meeting for November 19, 2024 at 5pm. – Action (Rubio)

UNFINISHED BUSINESS:

COMMITTEE REPORTS:

9. Capital Improvement Program Committee (Moody/Carapiet)
10. Finance & Fiscal Oversight Committee (Benediktsson/Carapiet)
11. Governance Committee (No Meeting)
12. Personnel Committee (No Meeting)
13. Solar Ad-Hoc Meeting (Moody/Benediktsson)

OTHER BUSINESS:

ENVIRONMENTAL:

CORRESPONDENCE:

INFORMATIONAL ITEMS:

CLOSED SESSION:

ADJOURNMENT:

The Board will be asked to adjourn the meeting to a Special Board Meeting on November 19, 2024, at 5:00 P.M.

At its discretion, the Board of Directors may consider the above-agenda items out of the order in which they appear currently. Accessible public meetings: Upon request, the District will provide written agenda materials in appropriate alternate formats, or disability-related modification or accommodation, including auxiliary aids or services to enable individual with disabilities to participate in public meetings. Please submit written requests to the District at P.O. Box 227, Tiburon, CA 94920 or rdohrmann@sani5.org at least two days prior to the meeting.

Omar Arias-Montez, President
John Carapiet, Vice President
Richard Snyder, Secretary

Item #1
Catharine Benediktsson, Director
Tod Moody, Director

**NOTICE AND AGENDA
Regular Board Meeting
at Sanitary District No. 5 of Marin County
Thursday, September 19th, 2024**

5:00 P.M. REGULAR BOARD MEETING

Teleconference Location:

Director Richard Snyder 10 Pomander Walk Belvedere CA 94920	Director Catherine Benediktsson 2352 Mar East Street Tiburon CA 94920
---	---

PURSUANT TO THE RALPH M. BROWN ACT, ALL VOTES SHALL BE BY ROLL CALL DUE TO DIRECTOR SNYDER TELECONFERENCE FROM 10 Pomander Walk Belvedere CA 94920 & DIRECTOR BENEDIKTSSON FROM 2352 Mar East Street Tiburon CA 94920

ROLL CALL: Omar Arias-Montez, Tod Moody, Richard Snyder , John Carapiet
Catherine Benediktsson arrived @ 5:01pm

PUBLIC COMMENTS: The public is invited to address the Board on items that do not appear on the agenda and are within the subject matter jurisdiction of the Board. The Brown Act does not allow the Board to take action on any public comment. Please limit public comments to no more than three minutes. **None**

DIRECTORS' COMMENTS AND/OR AGENDA REQUESTS: Director Moody requested the creation of a Solar Power Ad-Hoc Committee, President Arias- appointed Director Moody and Benediktsson to the ad-hoc with John Carapiet as the alternate.

CONSENT CALENDAR:

1. Approval of August 15th, 2024 Regular Board Meeting Minutes
2. Review and receive all electronic fund transfers (EFTs) and approve warrants from August 9th, 2024, through September 12th, 2024, (JP Morgan Chase Bank, check no.10751 through check no. 10809, all transactions totaling \$436,042.72) and receive August 2024 payroll, in the sum of \$143,234.09 (Rubio)
3. Receipt of Financial Reports through September 12, 2024 (Rubio)

Motion to approve consent calendar

(M/S Snyder/Benediktsson 5-0-0-0)

Ayes: Arias-Montez, Snyder, Benediktsson, Carapiet, Moody

Noes: None

Absent: None

Abstain: None

MANAGEMENT REPORTS:

4. District Manager Summary Report (Rubio) **Manager Rubio provided update**

NEW BUSINESS:

Public Hearing

5. Adoption of Ordinances pertaining to the Updated 2024 Sewer Capacity Fees and Permit/Inspection Fees - (Rubio)

- a. Adoption of Ordinance 2024-01 *“AN ORDINANCE OF SANITARY DISTRICT NO. 5 OF MARIN COUNTY RAISING THE CONNECTION FEES TO THE DISTRICT'S SEWER SYSTEM AND AMENDING ORDINANCE NOS. 70-1, 79-1, 06-01, 06-02, 14-01(B) AND ALL OTHER ORDINANCES AS THEY PERTAIN TO THE SETTING OF CONNECTION FEES”* - Action (Rubio)

Motion to adopt Ordinance 2024-01 as written

(M/S Snyder/Benediktsson 5-0-0-0)

Ayes: Arias-Montez, Snyder, Benediktsson, Carapiet, Moody

Noes: None

Absent: None

Abstain: None

- b. Adoption of Ordinance 2024-02 *“AN AMENDED ORDINANCE REGULATING THE USE OF PUBLIC AND PRIVATE SEWERS AND DRAINS, THE INSTALLATION AND CONNECTION OF BUILDING SEWERS, THE INSTALLATION OF SEWER LATERALS AND PUBLIC SEWER MAIN EXTENSIONS, PROVIDING PERMITS AND FIXING FEES FOR THE INSTALLATION AND CONNECTION OF SANITARY SEWERS, REGULATING THE DISCHARGE OF WATERS AND WASTES INTO THE PUBLIC SEWER SYSTEM, AND PROVIDING PENALTIES FOR THE VIOLATION OF THE PROVISIONS THEREOF”*- Action (Rubio)

Motion to adopt Ordinance 2024-02 as written

(M/S Snyder/Moody 5-0-0-0)

Ayes: Arias-Montez, Snyder, Benediktsson, Carapiet, Moody

Noes: None

Absent: None

Abstain: None

6. Declaration of Surplus Property – Action (Rubio)

Motion to declare Old Boom Truck surplus Property and authorize the General Manager to dispose through trade or open bid.

(M/S Snyder/Arias 5-0-0-0)

Ayes: Arias-Montez, Snyder, Benediktsson, Carapiet, Moody

Noes: None

Absent: None

Abstain: None

7. Review and discuss updated draft agreement with Lystek for the acceptance of the Districts Bio-Solids and authorizing the District Manager to proceed with entering into a new agreement with Lystek for Bio-Solids deliveries to the Lystek Facility located in Fairfield CA. -Action (Rubio)

Motion to accept new agreement and authorize the General Manger to enter into a new agreement with Lystek

(M/S Snyder/Carapiet 5-0-0-0)

Ayes: Arias-Montez, Snyder, Benediktsson, Carapiet, Moody

Noes: None

Absent: None

Abstain: None

8. Consideration to move funds to CLASS Account from LAIF for the funding of the Emergency Reserve Fund and CALPERS Reserve Fund- Action (Rubio)

Motion to make a transfer of funds as recommended by the General Manager to the Disaster Recovery Reserve Fund and CALPERS UAL Reserve Fund

(M/S Snyder/Benediktsson 5-0-0-0)

Ayes: Arias-Montez, Snyder, Benediktsson, Carapiet, Moody

Noes: None

Absent: None

Abstain: None

UNFINISHED BUSINESS:

COMMITTEE REPORTS:

9. Capital Improvement Program Committee (Moody/Carapiet)
10. Finance & Fiscal Oversight Committee (Benediktsson/Carapiet)
11. Governance Committee (No Meeting)
12. Personnel Committee (No Meeting)

OTHER BUSINESS:

ENVIRONMENTAL:

CORRESPONDENCE:

INFORMATIONAL ITEMS:

CLOSED SESSION:

ADJOURNMENT:

The Board will be asked to adjourn the meeting to a Regular Board Meeting on October 17, 2024, at 5:00 P.M.

Approved:

Attest:

Omar Arias-Montez
Board President

Richard Snyder
Board Secretary

At its discretion, the Board of Directors may consider the above-agenda items out of the order in which they appear currently. Accessible public meetings: Upon request, the District will provide written agenda materials in appropriate alternate formats, or disability-related modification or accommodation, including auxiliary aids or services to enable individual with disabilities to participate in public meetings. Please submit written requests to the District at P.O. Box 227, Tiburon, CA 94920 or rdohrmann@sani5.org at least two days prior to the meeting.

Sanitary District No.5 of Marin County

Warrant List Summary

September 13 through October 10, 2024

10/05/24

Date	Num	Name	Memo	Amount
JP Morgan Chase - Primary 7399				
09/18/2024	EFT	CalPERS (Health Premium)	Health Premium - Oct 2024	-16,065.64
09/18/2024	EFT	CalPERS (Pension)	Pension - Aug 2024	-25,213.42
09/18/2024	EFT	CalPERS (457 Def Comp)	457 Contributions, semi-monthly, 9/15/24	-6,439.34
10/03/2024	EFT	CalPERS (457 Def Comp)	457 Contributions, semi-monthly, 9/30/24	-6,439.34
10/03/2024	EFT	CalPERS (Pension)	Pension - Sept 2024	-25,213.42
09/19/2024	10810	Alhambra - Primo Water	drinking water service - Aug 2024	-27.46
09/19/2024	10811	AT&T	Paradise Cove & Pumps & Lines Telephones: 8/28/24-9/27/24	-581.41
09/19/2024	10812	AVEVA Select California	annual renewals of (3) softwares	-14,470.00
09/19/2024	10813	Bay Alarm	monitoring services: security alarm & fire, Oct-Dec 2024	-258.00
09/19/2024	10814	Brelje and Race Laboratories, Inc.	samples submitted - Aug 2024	-1,584.00
09/19/2024	10815	California Bank and Trust	MP upgrade: principal & interest due	-692,642.01
09/19/2024	10816	Caltest Analytical Laboratory	Lab Monitoring - Aug 2024	-1,654.90
09/19/2024	10817	Caltronics Business Systems, Inc.	copier base rate & usage charge, Aug 2024	-183.87
09/19/2024	10818	D&K Auto Service	2013 Ford F250, oil & filter	-184.13
09/19/2024	10819	East Bay Muni Utility District	FY25 BACWA Membership & Special Program Fees	-5,074.00
09/19/2024	10820	Fastenal Company	MP parts	-568.34
09/19/2024	10821	FireMaster	annual maintenance & testing, extinguishers	-1,025.00
09/19/2024	10822	Golden State Lumber	Douglas fir wood, strong bolts, nails, plate washers	-2,273.27
09/19/2024	10823	Grainger	water suction hose, parking curbs & delineator posts	-1,270.68
09/19/2024	10824	HDR Engineering Inc	Digester Cleaning & Rehab Project: Prof Serv 7/28/24-8/24/24	-18,633.49
09/19/2024	10825	Herc Rentals, Inc.	propane fuel for forklift	-222.58
09/19/2024	10826	HireRight, LLC	background screening services, Aug 2024	-110.12
09/19/2024	10827	Jackson's Hardware, Inc.	fuel for hedge trimmer	-218.49
09/19/2024	10828	JM Integration, LLC	screw press panel upgrade	-25,880.00
09/19/2024	10829	McMaster-Carr Supply Company	For MP & SASM: push-to-connect tube fitting for chemicals	-573.83
09/19/2024	10830	MISCOwater	ReNu pumphead, spare	-1,395.94
09/19/2024	10831	Nute Engineering Corp.	Cove Rd Pump Station Improv - Engineering Services Aug 2024	-3,529.00
09/19/2024	10832	Sewer Tech Inc	File Storage Building, retaining wall addition	-38,900.00
09/19/2024	10833	Telstar Instruments	install radio equipment/field work performed	-5,399.00
09/19/2024	10834	Univar Solutions	Sodium bisulfite bulk & sodium bicarb bags, Sept 2024	-10,239.74
09/19/2024	10835	Verizon Wireless	pump station telephones, 8/9/24-9/8/24	-229.67
09/19/2024	10836	Waste Management, Redwood Landfill	garbage service - Aug 2024	-2,416.15
10/10/2024	10837	Alameda Electrical Distributors, Inc.	materials for new storage shed, electrical box covers for Belv 8 & Tib 4	-2,521.89
10/10/2024	10838	Amazon Capital Services (Amazon Busine...	Stmt Date 9/30/24:batteries for CMC control panels, emergency lights/m...	-219.80
10/10/2024	10839	Banshee Networks, Inc.	computer network services - Aug 2024	-1,684.53
10/10/2024	10840	California Service Tool	drill bits, PVC supplies	-127.41
10/10/2024	10841	Cintas Corporation	weekly - scraper & towels, Sept 2024, and (2) uniform clothing purchases	-808.93
10/10/2024	10842	Comcast Business (Internet) *9465	cable, internet, voice - Oct 2024	-688.71
10/10/2024	10843	Comcast Business (VOIP) *5517	Business Voice Edge - Sept & Oct 2024	-768.63
10/10/2024	10844	DKF Solutions Group, LLC	monthly Training Link - Sept & Oct 2024	-924.00
10/10/2024	10845	Fastenal Company	10 invoices: louvered panel, latex gloves, Plant parts & supplies	-7,055.19
10/10/2024	10846	Frank A. Olsen Company	replacement valves that were taken from Digester project	-8,075.45
10/10/2024	10847	Golden State Lumber	Douglas Fir, Plywood, Microlam, HardiePlank siding, HardieTrim smooth	-12,048.18
10/10/2024	10848	Goodman Building Supply Co.	Stmt Date 9/25/24: Plant supplies, Tib PS4 materials	-644.06
10/10/2024	10849	Hardiman Construction / Trenchless Titan	Progress Billing #4: 2022 Sewer Rehab Project-Tib & Belv	-171,134.00
10/10/2024	10850	HF&H Consultants, LLC	2022 Sewer Rate Study - Aug 2024	-885.00
10/10/2024	10851	Home Depot Credit Services *2889	tools for new service truck, artificial lawn	-2,479.74
10/10/2024	10852	Jackson's Hardware, Inc.	rain gear & safety PPE for new hire Nate	-592.06
10/10/2024	10853	Jill Kalehua, DMMS	Accounting Services - Sept 2024	-3,805.20
10/10/2024	10854	Ken Grady Company, Inc.	flow meters, air pumps, air filters, sensor	-4,623.07
10/10/2024	10855	Linscott Engineering Contractors Inc.	Sludge Valve Replacements-Leak Investigation: Sept 2024	-2,846.94
10/10/2024	10856	McCampbell Analytical, Inc.	chronic toxicity screening - Sept 2024	-6,345.00
10/10/2024	10857	Mill Valley Refuse Serv (Garbage) *2945	garbage service - Oct 2024	-290.76
10/10/2024	10858	NSI Lab Solutions, Inc.	lab chemicals	-1,949.00
10/10/2024	10859	Ongaro & Sons, Inc	service call: Belv Hawthorne Nursery School, DOS 9/19/24	-468.19
10/10/2024	10860	Pacific Gas & Electric	Stmt Date 9/26/24	-30,059.45
10/10/2024	10861	Pacific Gas & Electric (Engineering)	engineering advance - EP Cove Rd Belvedere	-3,500.00
10/10/2024	10862	Peterson CAT	service check ups for all generators	-12,059.44
10/10/2024	10863	Roy's Sewer Service, Inc.	2001 Paradise Dr & Belvedere resident	-1,762.50
10/10/2024	10864	Special Dist Risk Mgmt Authority (SDRMA)	Basic Life, ADD, LTD, Dental & Vision - Nov 2024	-1,413.43
10/10/2024	10865	TESCO Controls, Inc.	equipment repairs: June & July 2024	-4,109.75
10/10/2024	10866	The Ark Newspaper	(4) legal notifications - advertising	-4,680.00
10/10/2024	10867	U.S. Bank cc *3611	US postage stamps	-219.00
10/10/2024	10868	WorkSmart Automation, Inc.	service call: configure the new BPS 8 Pump Station screens & tags, Se...	-2,035.00
Total JP Morgan Chase - Primary 7399				-1,199,740.55
TOTAL				-1,199,740.55

10/05/24

**Sanitary District No.5 of Marin County
Warrant List Detail**

September 13 through October 10, 2024

<u>Num</u>	<u>Type</u>	<u>Date</u>	<u>Name</u>	<u>Memo</u>	<u>Account</u>	<u>Paid Amo...</u>
EFT	Check	09/18/202	CalPERS (Health Premi...	Health Premium - Oct 2024	JP Morgan Chase - Primary ...	
				(10) Active Employee Health - Oct 2024	8020.05 · Employee Health	-20,277.98
				Active Employee Health, retroactive credit: Arlee Hill - Oct ...	8020.05 · Employee Health	5,311.34
				(7) Retiree Health - Oct 2024	8022.05 · Retiree Health	<u>-1,099.00</u>
TOTAL						-16,065.64
EFT	Check	09/18/202	CalPERS (Pension)	Pension - Aug 2024	JP Morgan Chase - Primary ...	
				Pepra, Aug 2024	8019.05 · PERS Retirement	-10,102.80
				Classic, Aug 2024	8019.05 · PERS Retirement	<u>-15,110.62</u>
TOTAL						-25,213.42
EFT	Check	09/18/202	CalPERS (457 Def Comp)	457 Contributions, semi-monthly, 9/15/24	JP Morgan Chase - Primary ...	
				457 Contributions, semi-monthly, 9/15/24	8008 · Deferred Comp 457	<u>-6,439.34</u>
TOTAL						-6,439.34
EFT	Check	10/03/202	CalPERS (457 Def Comp)	457 Contributions, semi-monthly, 9/30/24	JP Morgan Chase - Primary ...	
				457 Contributions, semi-monthly, 9/30/24	8008 · Deferred Comp 457	<u>-6,439.34</u>
TOTAL						-6,439.34
EFT	Check	10/03/202	CalPERS (Pension)	Pension - Sept 2024	JP Morgan Chase - Primary ...	
				Pepra, Sept 2024	8019.05 · PERS Retirement	-10,102.80
				Classic, Sept 2024	8019.05 · PERS Retirement	<u>-15,110.62</u>
TOTAL						-25,213.42

10/05/24

**Sanitary District No.5 of Marin County
Warrant List Detail**

September 13 through October 10, 2024

Num	Type	Date	Name	Memo	Account	Paid Amo...
10810	Bill Pmt -Check	09/19/202	Alhambra - Primo Water	drinking water service - Aug 2024	JP Morgan Chase - Primary ...	
12012...	Bill	09/13/202		drinking water service - Aug 2024	7023 · Janitorial Supplies & S...	-27.46
TOTAL						-27.46
10811	Bill Pmt -Check	09/19/202	AT&T	Paradise Cove & Pumps & Lines Telephones: 8/28/24-...	JP Morgan Chase - Primary ...	
Bill Dat...	Bill	08/28/202		8/28/24-9/27/24, Sept 2024 8/28/24-9/27/24, Sept 2024 late fee from previous invoice, Aug 2024	8532 · Paradise Cove Teleph... 8533 · Pumps & Lines Teleph... 8532 · Paradise Cove Teleph...	-368.43 -202.98 -10.00
TOTAL						-581.41
10812	Bill Pmt -Check	09/19/202	AVEVA Select California	annual renewals of (3) softwares	JP Morgan Chase - Primary ...	
447989	Bill	09/13/202		TV-SSA, TopView Software Support renewal, PO O-24-05...	8510 · Data/Alarms/IT Supp &...	-612.50
447988	Bill	09/13/202		TV-SSA, TopView Software Support renewal. PO O-24-05...	8510 · Data/Alarms/IT Supp &...	-437.50
				CF Premium WW HMI, renewal, PO O-24-057, 12/21/24-6...	8510 · Data/Alarms/IT Supp &...	-5,705.00
				CF Premium WW HMI, renewal, PO O-24-057, 7/1/25-12/...	8510 · Data/Alarms/IT Supp &...	-5,705.00
				CF Premium Historian, renewal, PO O-24-057, 12/21/24-6...	8510 · Data/Alarms/IT Supp &...	-1,005.00
				CF Premium Historian, renewal, PO O-24-057, 7/1/25-12/...	8510 · Data/Alarms/IT Supp &...	-1,005.00
TOTAL						-14,470.00
10813	Bill Pmt -Check	09/19/202	Bay Alarm	monitoring services: security alarm & fire, Oct-Dec 2024	JP Morgan Chase - Primary ...	
21660...	Bill	09/03/202		security alarm monitoring service, Oct-Dec 2024 fire monitoring fee, Oct-Dec 2024	8510 · Data/Alarms/IT Supp &... 8510 · Data/Alarms/IT Supp &...	-57.00 -201.00
TOTAL						-258.00
10814	Bill Pmt -Check	09/19/202	Brelje and Race Laborat...	samples submitted - Aug 2024	JP Morgan Chase - Primary ...	
158344	Bill	09/10/202		samples submitted - Aug 2024 samples submitted - Aug 2024	7051 · Main Plant Lab Monitor... 7052 · Paradise Cove Monitori...	-1,464.00 -120.00
TOTAL						-1,584.00

10/05/24

**Sanitary District No.5 of Marin County
Warrant List Detail**

September 13 through October 10, 2024

<u>Num</u>	<u>Type</u>	<u>Date</u>	<u>Name</u>	<u>Memo</u>	<u>Account</u>	<u>Paid Amo...</u>
10815	Bill Pmt -Check	09/19/202	California Bank and Trust	MP upgrade: principal & interest due	JP Morgan Chase - Primary ...	
Stmnt D...	Bill	09/02/202		principal due interest due	9730.01 · Zion Loan - Principal 9730.02 · Zion Loan - Interest	-625,000.00 -67,642.01
TOTAL						-692,642.01
10816	Bill Pmt -Check	09/19/202	Caltest Analytical Labor...	Lab Monitoring - Aug 2024	JP Morgan Chase - Primary ...	
722725	Bill	09/11/202		Main Plant Lab Monitoring - Aug 2024 Paradise Cover Monitoring - Aug 2024	7051 · Main Plant Lab Monitor... 7052 · Paradise Cove Monitori...	-1,558.00 -96.90
TOTAL						-1,654.90
10817	Bill Pmt -Check	09/19/202	Caltronics Business Sy...	copier base rate & usage charge, Aug 2024	JP Morgan Chase - Primary ...	
4169106	Bill	09/06/202		Konica Minolta/KON-C308, usage charge, 8/2/24-9/1/24 base rate charge plus tax, 8/2/24-9/1/24	6047 · Office Supplies 6047 · Office Supplies	-90.76 -93.11
TOTAL						-183.87
10818	Bill Pmt -Check	09/19/202	D&K Auto Service	2013 Ford F250, oil & filter	JP Morgan Chase - Primary ...	
78922	Bill	09/09/202		2013 Ford F250, oil & filter. PO M-24-017	7072 · Maintenance	-184.13
TOTAL						-184.13
10819	Bill Pmt -Check	09/19/202	East Bay Muni Utility Di...	FY25 BACWA Membership & Special Program Fees	JP Morgan Chase - Primary ...	
9009070	Bill	08/30/202		FY25 BACWA Membership & Special Program Fees, AJE...	7062 · Permits/Fees - General	-5,074.00
TOTAL						-5,074.00

10/05/24

**Sanitary District No.5 of Marin County
Warrant List Detail**

September 13 through October 10, 2024

<u>Num</u>	<u>Type</u>	<u>Date</u>	<u>Name</u>	<u>Memo</u>	<u>Account</u>	<u>Paid Amo...</u>
10820	Bill Pmt -Check	09/19/202	Fastenal Company	MP parts	JP Morgan Chase - Primary ...	
CAPE...	Bill	09/09/202		sprayer, PO 0-24-027	7022 · Plant Maint. Parts & Se...	-15.39
CAPE...	Bill	09/09/202		stainless steel fasteners, lubricant, adhesives. PO O-24-039	7021 · Plant Maintenance Sup...	-552.95
TOTAL						-568.34
10821	Bill Pmt -Check	09/19/202	FireMaster	annual maintenance & testing, extinguishers	JP Morgan Chase - Primary ...	
00012...	Bill	08/30/202		annual maintenance & testing, extinguishers	8515 · Safety	-1,025.00
TOTAL						-1,025.00
10822	Bill Pmt -Check	09/19/202	Golden State Lumber	Douglas fir wood, strong bolts, nails, plate washers	JP Morgan Chase - Primary ...	
7156418	Bill	09/06/202		strong bolts	7022 · Plant Maint. Parts & Se...	-37.97
7159655	Bill	09/09/202		douglas fir wood	7022 · Plant Maint. Parts & Se...	-2,121.64
7162771	Bill	09/10/202		smooth nails & plate washers	7022 · Plant Maint. Parts & Se...	-113.66
TOTAL						-2,273.27
10823	Bill Pmt -Check	09/19/202	Grainger	water suction hose, parking curbs & delineator posts	JP Morgan Chase - Primary ...	
92359...	Bill	09/03/202		water suction hose. PO 0-24-038	7022 · Plant Maint. Parts & Se...	-863.64
92438...	Bill	09/10/202		parking curb stops & delineator posts. PO O-24-054	7028 · Grounds Maintenance	-407.04
TOTAL						-1,270.68
10824	Bill Pmt -Check	09/19/202	HDR Engineering Inc	Digester Cleaning & Rehab Project: Prof Serv 7/28/24-...	JP Morgan Chase - Primary ...	
12006...	Bill	09/06/202		Digester Cleaning & Rehab Project: Prof Serv 7/28/24-8/2...	6017 · Consulting Fees	-18,633.49
TOTAL						-18,633.49

10/05/24

**Sanitary District No.5 of Marin County
Warrant List Detail**

September 13 through October 10, 2024

<u>Num</u>	<u>Type</u>	<u>Date</u>	<u>Name</u>	<u>Memo</u>	<u>Account</u>	<u>Paid Amo...</u>
10825	Bill Pmt -Check	09/19/202	Herc Rentals, Inc.	propane fuel for forklift	JP Morgan Chase - Primary ...	
34921...	Bill	09/10/202		propane fuel for forklift. PO O-24-056	7071 · Fuel	-222.58
TOTAL						-222.58
10826	Bill Pmt -Check	09/19/202	HireRight, LLC	background screening services, Aug 2024	JP Morgan Chase - Primary ...	
1000-I...	Bill	08/31/202		background screening services, Nathaniel Adams, Aug 20...	6017 · Consulting Fees	-110.12
TOTAL						-110.12
10827	Bill Pmt -Check	09/19/202	Jackson's Hardware, Inc.	fuel for hedge trimmer	JP Morgan Chase - Primary ...	
162786	Bill	09/12/202		fuel for hedge trimmer. PO M-24-018	7028 · Grounds Maintenance	-218.49
TOTAL						-218.49
10828	Bill Pmt -Check	09/19/202	JM Integration, LLC	screw press panel upgrade	JP Morgan Chase - Primary ...	
23405	Bill	09/06/202		screw press panel upgrade. PO 0-24-052	7022 · Plant Maint. Parts & Se...	-25,880.00
TOTAL						-25,880.00
10829	Bill Pmt -Check	09/19/202	McMaster-Carr Supply ...	For MP & SASM: push-to-connect tube fitting for che...	JP Morgan Chase - Primary ...	
32834...	Bill	09/05/202		push-to-connect tube fittings for chemicals, SASM. PO 0-2...	7026 · SASM Supplies & Chem	-176.07
32843...	Bill	09/05/202		push-to-connect tube fittings for chemicals. PO 0-24-046	7022 · Plant Maint. Parts & Se...	-397.76
TOTAL						-573.83
10830	Bill Pmt -Check	09/19/202	MISCOwater	ReNu pumpehead, spare	JP Morgan Chase - Primary ...	
36751...	Bill	08/21/202		ReNu pumpehead, spare. PO 0-24-017	7022 · Plant Maint. Parts & Se...	-1,395.94
TOTAL						-1,395.94

10/05/24

**Sanitary District No.5 of Marin County
Warrant List Detail**

September 13 through October 10, 2024

<u>Num</u>	<u>Type</u>	<u>Date</u>	<u>Name</u>	<u>Memo</u>	<u>Account</u>	<u>Paid Amo...</u>
10831	Bill Pmt -Check	09/19/202	Nute Engineering Corp.	Cove Rd Pump Station Improv - Engineering Services ...	JP Morgan Chase - Primary ...	
27373	Bill	09/12/202		Cove Rd Pump Station Improv - Engineering Services Au...	6017 · Consulting Fees	-3,529.00
TOTAL						-3,529.00
10832	Bill Pmt -Check	09/19/202	Sewer Tech Inc	File Storage Building, retaining wall addition	JP Morgan Chase - Primary ...	
2020/1...	Bill	09/11/202		File Storage Building, retaining wall addition	7022 · Plant Maint. Parts & Se...	-38,900.00
TOTAL						-38,900.00
10833	Bill Pmt -Check	09/19/202	Telstar Instruments	install radio equipment/field work perfomed	JP Morgan Chase - Primary ...	
123257	Bill	09/09/202		install radio equipment/field work perfomed 8/27/24-8/28/24	7011 · Pumps & Lines Mainte...	-5,399.00
TOTAL						-5,399.00
10834	Bill Pmt -Check	09/19/202	Univar Solutions	Sodium bisulfite bulk & sodium bicarb bags, Sept 2024	JP Morgan Chase - Primary ...	
52391...	Bill	09/04/202		Sod Bicarb bags. PO 0-24-040	7042 · Paradise Supplies & C...	-2,351.72
52401...	Bill	09/09/202		Sod bisulfite bulk. PO O-24-042	7024 · Main Plant Chemicals	-7,888.02
TOTAL						-10,239.74
10835	Bill Pmt -Check	09/19/202	Verizon Wireless	pump station telephones, 8/9/24-9/8/24	JP Morgan Chase - Primary ...	
99733...	Bill	09/08/202		pump station telephones, 8/9/24-9/8/24	8533 · Pumps & Lines Teleph...	-229.67
TOTAL						-229.67
10836	Bill Pmt -Check	09/19/202	Waste Management, Re...	garbage service - Aug 2024	JP Morgan Chase - Primary ...	
01114...	Bill	09/01/202		Garbage service - Aug 2024	7029 · Main Plant Sludge Disp...	-2,416.15
TOTAL						-2,416.15

10/05/24

**Sanitary District No.5 of Marin County
Warrant List Detail**

September 13 through October 10, 2024

Num	Type	Date	Name	Memo	Account	Paid Amo...
10837	Bill Pmt -Check	10/10/202	Alameda Electrical Distr...	materials for new storage shed, electrical box coves f...	JP Morgan Chase - Primary ...	
S5889...	Bill	09/13/202		materials for new storage shed up top. PO M-24-019	7027 · Electrical & Instrument	-987.70
S5889...	Bill	09/13/202		electrical box covers for Belvedere 8 & Tiburon 4. PO M-2...	7011 · Pumps & Lines Mainte...	-18.81
S5889...	Bill	09/16/202		materials for new storage shed up top. PO M-24-019	7027 · Electrical & Instrument	-607.57
S5889...	Bill	09/16/202		electrical box covers for Belvedere 8 & Tiburon 4. PO M-2...	7011 · Pumps & Lines Mainte...	-187.62
S5889...	Bill	09/18/202		materials for new storage shed up top. PO M-24-019	7027 · Electrical & Instrument	-720.19
TOTAL						-2,521.89
10838	Bill Pmt -Check	10/10/202	Amazon Capital Service...	Stmnt Date 9/30/24:batteries for CMC control panels, e...	JP Morgan Chase - Primary ...	
Stmnt D...	Bill	09/30/202		Inv IG1D-MH9N-TRM4, batteries for CMC control panels. ...	7011 · Pumps & Lines Mainte...	-105.71
				Inv IG1D-MH9N-TRM4, batteries for emergency lights/mai...	7022 · Plant Maint. Parts & Se...	-45.14
				Inv 1TNL-94F3-WPWX, urinal screen deodorizer 12 pk. Ja...	7023 · Janitorial Supplies & S...	-25.97
				Inv 1JLL-WGKC-XWPD, misc supplies. PO O-24-060	7021 · Plant Maintenance Sup...	-42.98
TOTAL						-219.80
10839	Bill Pmt -Check	10/10/202	Banshee Networks, Inc.	computer network services - Aug 2024	JP Morgan Chase - Primary ...	
16398	Bill	09/25/202		computer network services - Aug 2024	8510 · Data/Alarms/IT Supp &...	-1,684.53
TOTAL						-1,684.53
10840	Bill Pmt -Check	10/10/202	California Service Tool	drill bits, PVC supplies	JP Morgan Chase - Primary ...	
S5831...	Bill	07/01/202		drill bits, PVC supplies, PO 753069 Joe. Inv date is 6/14/24.	7022 · Plant Maint. Parts & Se...	-127.41
TOTAL						-127.41
10841	Bill Pmt -Check	10/10/202	Cintas Corporation	weekly - scraper & towels, Sept 2024, and (2) uniform ...	JP Morgan Chase - Primary ...	
Stmnt D...	Bill	09/30/202		weekly - scraper & towels, Inv 4204362141, 9/6/24	7023 · Janitorial Supplies & S...	-35.00
				weekly - scraper & towels, Inv 4205110241, 9/13/24	7023 · Janitorial Supplies & S...	-35.00
				weekly - scraper & towels, Inv 4205827834, 9/20/24	7023 · Janitorial Supplies & S...	-35.00
				weekly - scraper & towels, Inv 4206554548, 9/27/24	7023 · Janitorial Supplies & S...	-35.00

10/05/24

**Sanitary District No.5 of Marin County
Warrant List Detail**

September 13 through October 10, 2024

Num	Type	Date	Name	Memo	Account	Paid Amo...
				uniform clothing, PO O-24-058	8515 · Safety	-306.44
				uniform clothing, PO O-24-034	8515 · Safety	-362.49
TOTAL						-808.93
10842	Bill Pmt -Check	10/10/202	Comcast Business (Inte...	cable, internet, voice - Oct 2024	JP Morgan Chase - Primary ...	
Bill Dat...	Bill	09/26/202		Business Cable, Internet, Voice - Oct 2024	8531 · Main Plant Telephones	-688.71
TOTAL						-688.71
10843	Bill Pmt -Check	10/10/202	Comcast Business (VOI...	Business Voice Edge - Sept & Oct 2024	JP Morgan Chase - Primary ...	
21728...	Bill	09/01/202		Business Voice Edge - Sept 2024	8531 · Main Plant Telephones	-378.46
21982...	Bill	10/01/202		Business Voice Edge - Oct 2024	8531 · Main Plant Telephones	-384.49
				Business Voice Edge, late charge, Sept 2024	8531 · Main Plant Telephones	-5.68
TOTAL						-768.63
10844	Bill Pmt -Check	10/10/202	DKF Solutions Group, L...	monthly Training Link - Sept & Oct 2024	JP Morgan Chase - Primary ...	
22436	Bill	09/01/202		TrainingLink monthly subscription - Sept 2024	8515 · Safety	-462.00
22480	Bill	10/01/202		TrainingLink monthly subscription - Oct 2024	8515 · Safety	-462.00
TOTAL						-924.00
10845	Bill Pmt -Check	10/10/202	Fastenal Company	10 invoices: louvered panel, latex gloves, Plant parts ...	JP Morgan Chase - Primary ...	
CAPE...	Bill	09/11/202	Sewerage Agency of Sou...	1/2 CPVC Ell SR/F. PO O-24-049 SASM	7026 · SASM Supplies & Chem	-43.84
CAPE...	Bill	09/11/202		1/2 coupling SR. PO O-24-050	7022 · Plant Maint. Parts & Se...	-294.98
CAPE...	Bill	09/11/202		parts. PO O-24-039	7022 · Plant Maint. Parts & Se...	-1,805.82
CAPE...	Bill	09/18/202		1/2 CPVC 90 ELL SR/F. PO O-24-050	7022 · Plant Maint. Parts & Se...	-102.30
CAPE...	Bill	09/18/202		316 SS Core Filter. PO O-24-024	7022 · Plant Maint. Parts & Se...	-572.64
CAPE...	Bill	09/18/202		36" x 61" louvered panel. PO O-24-021	7021 · Plant Maintenance Sup...	-1,356.59
CAPE...	Bill	09/18/202		parts. PO O-24-039	7022 · Plant Maint. Parts & Se...	-97.88
CAPE...	Bill	09/20/202		parts. PO O-24-039	7022 · Plant Maint. Parts & Se...	-2,137.26

10/05/24

**Sanitary District No.5 of Marin County
Warrant List Detail**

September 13 through October 10, 2024

<u>Num</u>	<u>Type</u>	<u>Date</u>	<u>Name</u>	<u>Memo</u>	<u>Account</u>	<u>Paid Amo...</u>
CAPE...	Bill	09/25/202		parts. PO O-24-039	7022 · Plant Maint. Parts & Se...	-159.35
CAPE...	Bill	09/25/202		latex gloves. PO O-24-024	7021 · Plant Maintenance Sup...	-484.53
TOTAL						-7,055.19
10846	Bill Pmt -Check	10/10/202	Frank A. Olsen Company	replacement valves that were taken from Digester proj...	JP Morgan Chase - Primary ...	
254581	Bill	10/03/202		replacement valves that were taken from Digester project. ...	7022 · Plant Maint. Parts & Se...	-8,075.45
TOTAL						-8,075.45
10847	Bill Pmt -Check	10/10/202	Golden State Lumber	Douglas Fir, Plywood, Microlam, HardiePlank siding, ...	JP Morgan Chase - Primary ...	
7169334	Bill	09/12/202		plywood, douglas fir, microlam, strong bolts	7022 · Plant Maint. Parts & Se...	-5,719.26
7194576	Bill	09/24/202		HardiePlank siding cedar & HardieTrim smooth, plywood	7022 · Plant Maint. Parts & Se...	-6,328.92
TOTAL						-12,048.18
10848	Bill Pmt -Check	10/10/202	Goodman Building Sup...	Stmt Date 9/25/24: Plant supplies, Tib PS4 materials	JP Morgan Chase - Primary ...	
Stmt D...	Bill	09/25/202		misc supplies/parts for plant, Inv 895946, PO M-24-013 plant parts, misc fitting, Inv 896381, PO O-24-047 materials for Tiburon PS #4, Inv 896868, PO M-24-020 plant supplies, Inv 897540, PO O-24-061	7021 · Plant Maintenance Sup... 7022 · Plant Maint. Parts & Se... 7011 · Pumps & Lines Mainte... 7023 · Janitorial Supplies & S...	-335.82 -145.57 -99.05 -63.62
TOTAL						-644.06
10849	Bill Pmt -Check	10/10/202	Hardiman Construction ...	Progress Billing #4: 2022 Sewer Rehab Project-Tib & ...	JP Morgan Chase - Primary ...	
4	Bill	09/23/202		Progress Billing #4: 2022 Sewer Rehab Project-Tib & Belv	9301 · Tiburon Sewer Line Re...	-171,134.00
TOTAL						-171,134.00
10850	Bill Pmt -Check	10/10/202	HF&H Consultants, LLC	2022 Sewer Rate Study - Aug 2024	JP Morgan Chase - Primary ...	
9721505	Bill	09/23/202		2022 Sewer Rate Study - Aug 2024	6017 · Consulting Fees	-885.00
TOTAL						-885.00

10/05/24

**Sanitary District No.5 of Marin County
Warrant List Detail**

September 13 through October 10, 2024

Num	Type	Date	Name	Memo	Account	Paid Amo...
10851	Bill Pmt -Check	10/10/202	Home Depot Credit Serv...	tools for new service truck, artificial lawn	JP Morgan Chase - Primary ...	
Stmnt D...	Bill	09/15/202		Inv 34382, tools Inv 8600058, artificial lawn	7011 · Pumps & Lines Mainte... 7028 · Grounds Maintenance	-1,777.84 -701.90
TOTAL						-2,479.74
10852	Bill Pmt -Check	10/10/202	Jackson's Hardware, Inc.	rain gear & safety PPE for new hire Nate	JP Morgan Chase - Primary ...	
164171	Bill	10/02/202		new gear for Nate: rain gear & safety PPE. PO M-24-030	8520 · Personal Protection/Sa...	-592.06
TOTAL						-592.06
10853	Bill Pmt -Check	10/10/202	Jill Kalehua, DMMS	Accounting Services - Sept 2024	JP Morgan Chase - Primary ...	
Sept 2...	Bill	10/01/202		Accounting Services - Sept 2024	6008 · Audit & Accounting	-3,805.20
TOTAL						-3,805.20
10854	Bill Pmt -Check	10/10/202	Ken Grady Company, Inc.	flow meters, air pumps, air filters, sensor	JP Morgan Chase - Primary ...	
6063	Bill	09/20/202		parts. PO O-24-043	7022 · Plant Maint. Parts & Se...	-3,390.19
6064	Bill	09/20/202		parts. PO O-24-044	7022 · Plant Maint. Parts & Se...	-1,232.88
TOTAL						-4,623.07
10855	Bill Pmt -Check	10/10/202	Linscott Engineering C...	Sludge Valve Replacements-Leak Investigation: Sept ...	JP Morgan Chase - Primary ...	
4357	Bill	09/23/202		Sludge Valve Replacements-Leak Investigation: Sept 2024	7011 · Pumps & Lines Mainte...	-2,846.94
TOTAL						-2,846.94
10856	Bill Pmt -Check	10/10/202	McCampbell Analytical, ...	chronic toxicity screening - Sept 2024	JP Morgan Chase - Primary ...	
2409004	Bill	09/20/202		chronic toxicity screening: 9/2/24, 9/4/24, 9/6/24	7053 · Chronic Toxicity	-3,890.00
2409381	Bill	09/27/202		chronic toxicity screening: 9/9/24	7053 · Chronic Toxicity	-2,455.00
TOTAL						-6,345.00

10/05/24

**Sanitary District No.5 of Marin County
Warrant List Detail**

September 13 through October 10, 2024

<u>Num</u>	<u>Type</u>	<u>Date</u>	<u>Name</u>	<u>Memo</u>	<u>Account</u>	<u>Paid Amo...</u>
10857	Bill Pmt -Check	10/10/202	Mill Valley Refuse Serv (...	garbage service - Oct 2024	JP Morgan Chase - Primary ...	
00036...	Bill	10/01/202		Garbage service, Oct 2024	7028 · Grounds Maintenance	-290.76
TOTAL						-290.76
10858	Bill Pmt -Check	10/10/202	NSI Lab Solutions, Inc.	lab chemicals	JP Morgan Chase - Primary ...	
441073	Bill	09/20/202		lab chemicals. PO O-24-055	7025 · Lab Supplies & Chemic...	-1,949.00
TOTAL						-1,949.00
10859	Bill Pmt -Check	10/10/202	Ongaro & Sons, Inc	service call: Belv Hawthorne Nursery School, DOS 9/1...	JP Morgan Chase - Primary ...	
225909	Bill	09/19/202		plumbing evaluation, pull & reset toilet, DOS 9/19/24	7011 · Pumps & Lines Mainte...	-468.19
TOTAL						-468.19
10860	Bill Pmt -Check	10/10/202	Pacific Gas & Electric	Stmt Date 9/26/24	JP Morgan Chase - Primary ...	
Stmt D...	Bill	09/26/202		Stmt Date 9/26/24 Stmt Date 9/26/24 Stmt Date 9/26/24	8542 · Main Plant Utilities 8543 · Paradise Cove Utilities 8544 · Pump Station Utilities	-23,076.18 -2,564.54 -4,418.73
TOTAL						-30,059.45
10861	Bill Pmt -Check	10/10/202	Pacific Gas & Electric (...	engineering advance - EP Cove Rd Belvedere	JP Morgan Chase - Primary ...	
00083...	Bill	09/27/202		Engineering Advance: Project # P000327069. Application ...	9309 · BPS #1 Generator Rep...	-3,500.00
TOTAL						-3,500.00

10/05/24

**Sanitary District No.5 of Marin County
Warrant List Detail**

September 13 through October 10, 2024

Num	Type	Date	Name	Memo	Account	Paid Amo...
10862	Bill Pmt -Check	10/10/202	Peterson CAT	service check ups for all generators	JP Morgan Chase - Primary ...	
Stmt D...	Bill	09/30/202		generator service check, Inv SW270059991, PO M-24-014	7011 · Pumps & Lines Mainte...	-701.44
				generator service check, Inv SW270059992, PO M-24-014	7011 · Pumps & Lines Mainte...	-701.44
				generator service check, Inv SW270060002, PO M-24-014	7011 · Pumps & Lines Mainte...	-701.44
				generator service check, Inv SW270060003, PO M-24-014	7011 · Pumps & Lines Mainte...	-701.44
				generator service check, Inv SW270060005, PO M-24-014	7011 · Pumps & Lines Mainte...	-702.58
				generator service check, Inv SW270060006, PO M-24-014	7011 · Pumps & Lines Mainte...	-702.58
				generator service check, Inv SW270060015, PO M-24-014	7011 · Pumps & Lines Mainte...	-702.58
				generator service check, Inv SW270060016, PO M-24-014	7011 · Pumps & Lines Mainte...	-702.58
				generator service check, Inv SW270060023, PO M-24-014	7011 · Pumps & Lines Mainte...	-701.82
				generator service check, Inv SW270060024, PO M-24-014	7011 · Pumps & Lines Mainte...	-701.82
				generator service check, Inv SW270060025, PO M-24-014	7011 · Pumps & Lines Mainte...	-701.82
				generator service check, Inv SW270060026, PO M-24-014	7011 · Pumps & Lines Mainte...	-704.83
				generator service check, Inv SW270060027, PO M-24-014	7011 · Pumps & Lines Mainte...	-700.37
				generator service check, Inv SW270060028, PO M-24-014	7011 · Pumps & Lines Mainte...	-2,232.33
				generator service check, Inv SW270060029, PO M-24-014	7011 · Pumps & Lines Mainte...	-700.37
TOTAL						-12,059.44
10863	Bill Pmt -Check	10/10/202	Roy's Sewer Service, Inc.	2001 Paradise Dr & Belvedere resident	JP Morgan Chase - Primary ...	
228304	Bill	09/09/202		service call: 2001 Paradise Dr	7022 · Plant Maint. Parts & Se...	-1,410.00
228251	Bill	09/11/202		service call: 425 Bella Vista Ave, Belvedere	7011 · Pumps & Lines Mainte...	-352.50
TOTAL						-1,762.50
10864	Bill Pmt -Check	10/10/202	Special Dist Risk Mgmt ...	Basic Life, ADD, LTD, Dental & Vision - Nov 2024	JP Morgan Chase - Primary ...	
Sampl...	Bill	10/05/202		Basic Life & ADD, LTD, Dental, Vision - Nov 2024	8020.05 · Employee Health	-1,413.43
TOTAL						-1,413.43
10865	Bill Pmt -Check	10/10/202	TESCO Controls, Inc.	equipment repairs: June & July 2024	JP Morgan Chase - Primary ...	
00838...	Bill	09/23/202		equipment repair, DOS 6/27/24	7022 · Plant Maint. Parts & Se...	-2,653.50
				equipment repair, DOS 7/18/24	7022 · Plant Maint. Parts & Se...	-1,456.25
TOTAL						-4,109.75

10/05/24

Sanitary District No.5 of Marin County
Warrant List Detail

September 13 through October 10, 2024

Num	Type	Date	Name	Memo	Account	Paid Amo...
10866	Bill Pmt -Check	10/10/202	The Ark Newspaper	(4) legal notifications - advertising	JP Morgan Chase - Primary ...	
10000...	Bill	09/18/202		Legal 4619: Aug & Sept 2024	6001 · Advertising	-450.00
				Legal 4620: Aug & Sept 2024	6001 · Advertising	-450.00
10000...	Bill	09/25/202		Legal #4663, Sept 2024	6001 · Advertising	-410.00
				Legal #4664, Sept 2024	6001 · Advertising	-3,370.00
TOTAL						-4,680.00
10867	Bill Pmt -Check	10/10/202	U.S. Bank cc *3611	US postage stamps	JP Morgan Chase - Primary ...	
Stmt D...	Bill	09/25/202		postage: US stamps	6056 · Postage	-219.00
TOTAL						-219.00
10868	Bill Pmt -Check	10/10/202	WorkSmart Automation,...	service call: configure the new BPS 8 Pump Station s...	JP Morgan Chase - Primary ...	
5445	Bill	10/01/202		service call: configure the new BPS 8 Pump Station scree...	8510 · Data/Alarms/IT Supp &...	-2,035.00
TOTAL						-2,035.00

Sanitary District No.5 of Marin County Annual Budget vs Actual Expenses July 1 through October 10, 2024

	Jul 1 - Oct 10, 24	Budget	\$ Over Budget	% of Budget
Ordinary Income/Expense				
Income				
5000 · Property Taxes / AD VALOREM				
5001.2 · TEETER	5,869.74	999,999.00	-994,129.26	0.6%
5002 · UNSEC	0.00	16,000.00	-16,000.00	0.0%
5003 · PUNS / PRIOR UNSECURED	0.00	1,500.00	-1,500.00	0.0%
5004 · REDEMPTION / RDMPT	209.19	0.00	209.19	100.0%
5006 · SPLU	0.00	100.00	-100.00	0.0%
5041 · SUPSEC	806.25	20,000.00	-19,193.75	4.0%
5043 · SECU	0.00	0.00	0.00	0.0%
5046 · Excess ERAF	51,871.09	300,000.00	-248,128.91	17.3%
5280 · HOPTR	0.00	3,000.00	-3,000.00	0.0%
5483 · Other tax	7.78	7,000.00	-6,992.22	0.1%
Total 5000 · Property Taxes / AD VALOREM	58,764.05	1,347,599.00	-1,288,834.95	4.4%
5007 · Sewer Service Charge				
5007.1 · Sewer Service - Ops	109,885.77	5,115,266.00	-5,005,380.23	2.1%
5007.2 · Sewer Service - Cap	0.00	1,028,242.00	-1,028,242.00	0.0%
Total 5007 · Sewer Service Charge	109,885.77	6,143,508.00	-6,033,622.23	1.8%
5201 · INTEREST				
5201.1 · Interest County of Marin	1,832.19	100.00	1,732.19	1,832.2%
5201.2 · Interest LAIF	180,543.94	200,000.00	-19,456.06	90.3%
Total 5201 · INTEREST	182,376.13	200,100.00	-17,723.87	91.1%
5900.10 · Paradise Sewer Line Ext. Fees	0.00	0.00	0.00	0.0%
5900.3 · Connection Fees				
5900.31 · Collection	42,894.00	200,000.00	-157,106.00	21.4%
5900.34 · Treatment	51,542.00	200,000.00	-148,458.00	25.8%
Total 5900.3 · Connection Fees	94,436.00	400,000.00	-305,564.00	23.6%
5900.4 · Permit Inspection & Admin Fees	11,950.00	35,000.00	-23,050.00	34.1%
5900.5 · SASM Expense Reimb.	0.00	75,000.00	-75,000.00	0.0%
5900.9 · Other Income	980.75	0.00	980.75	100.0%
Total Income	458,392.70	8,201,207.00	-7,742,814.30	5.6%
Gross Profit	458,392.70	8,201,207.00	-7,742,814.30	5.6%
Expense				
6000 · Administrative Expenses				
6001 · Advertising	4,680.00	0.00	4,680.00	100.0%
6002 · Outreach & Newsletter	0.00	0.00	0.00	0.0%
6008 · Audit & Accounting	12,505.20	90,000.00	-77,494.80	13.9%
6017 · Consulting Fees	25,737.61	125,000.00	-99,262.39	20.6%
6018 · Travel & Meetings				
6018.1 · Meetings & Travel	9,964.19	17,000.00	-7,035.81	58.6%
6018.2 · Standby Mileage Expense Reimb	880.32	8,000.00	-7,119.68	11.0%
Total 6018 · Travel & Meetings	10,844.51	25,000.00	-14,155.49	43.4%
6020 · Continuing Education	4,878.50	10,000.00	-5,121.50	48.8%
6021 · County Fees	0.00	16,590.00	-16,590.00	0.0%
6024 · Director Fees	0.00	9,000.00	-9,000.00	0.0%
6025 · Dues & Subscriptions	2,442.74	35,000.00	-32,557.26	7.0%
6026 · Elections	0.00	10,000.00	-10,000.00	0.0%
6033 · Insurance				
6033.1 · Insurance - SD5 Property	69,285.84	100,000.00	-30,714.16	69.3%
6033.2 · Insurance - SD5 Liability	0.00	60,000.00	-60,000.00	0.0%
6033.3 · Insurance - SD5 Auto	3,432.00	10,000.00	-6,568.00	34.3%
Total 6033 · Insurance	72,717.84	170,000.00	-97,282.16	42.8%

Sanitary District No.5 of Marin County
Annual Budget vs Actual Expenses
 July 1 through October 10, 2024

	<u>Jul 1 - Oct 10, 24</u>	<u>Budget</u>	<u>\$ Over Budget</u>	<u>% of Budget</u>
6039 · Legal	4,288.00	50,000.00	-45,712.00	8.6%
6047 · Office Supplies	665.24	11,000.00	-10,334.76	6.0%
6056 · Postage	-2,188.70	1,300.00	-3,488.70	-168.4%
6059 · Pollution Prevention/Public Edu	0.00	5,500.00	-5,500.00	0.0%
6065 · Miscellaneous Expense	370.02	0.00	370.02	100.0%
Total 6000 · Administrative Expenses	136,940.96	558,390.00	-421,449.04	24.5%
7000 · Ops & Maintenance Expenses				
7010 · Pumps & Lines Maintenance				
7011 · Pumps & Lines Maintenance	37,589.22	200,000.00	-162,410.78	18.8%
7013 · Emergency Line Repair	17,119.16	100,000.00	-82,880.84	17.1%
Total 7010 · Pumps & Lines Maintenance	54,708.38	300,000.00	-245,291.62	18.2%
7020 · Main Plant Maintenance				
7021 · Plant Maintenance Supplies	2,746.54	80,000.00	-77,253.46	3.4%
7022 · Plant Maint. Parts & Service	129,526.44	300,000.00	-170,473.56	43.2%
7023 · Janitorial Supplies & Service	1,453.16	10,000.00	-8,546.84	14.5%
7024 · Main Plant Chemicals	41,617.49	165,000.00	-123,382.51	25.2%
7025 · Lab Supplies & Chemicals	2,243.68	25,000.00	-22,756.32	9.0%
7027 · Electrical & Instrument	2,315.46	30,000.00	-27,684.54	7.7%
7028 · Grounds Maintenance	3,003.66	8,000.00	-4,996.34	37.5%
7029 · Main Plant Sludge Disposal	12,146.56	55,000.00	-42,853.44	22.1%
Total 7020 · Main Plant Maintenance	195,052.99	673,000.00	-477,947.01	29.0%
7040 · Paradise Cove Plant Maint				
7041 · Paradise Parts & Service	23.49	20,000.00	-19,976.51	0.1%
7042 · Paradise Supplies & Chemicals	2,351.72	6,500.00	-4,148.28	36.2%
7043 · Paradise Sludge Disposal	0.00	3,000.00	-3,000.00	0.0%
Total 7040 · Paradise Cove Plant Maint	2,375.21	29,500.00	-27,124.79	8.1%
7050 · Monitoring				
7051 · Main Plant Lab Monitoring	7,043.70	50,000.00	-42,956.30	14.1%
7052 · Paradise Cove Monitoring	1,617.20	9,000.00	-7,382.80	18.0%
7053 · Chronic Toxicity	8,795.00	15,000.00	-6,205.00	58.6%
Total 7050 · Monitoring	17,455.90	74,000.00	-56,544.10	23.6%
7060 · Permits/Fees				
7061 · Main Plant NPDES Renewal	0.00	0.00	0.00	0.0%
7062 · Permits/Fees - General	9,195.67	50,000.00	-40,804.33	18.4%
7063 · Paradise Cove Permits/Fees	0.00	9,000.00	-9,000.00	0.0%
7064 · Paradise Cove NPDES Renewal	0.00	0.00	0.00	0.0%
Total 7060 · Permits/Fees	9,195.67	59,000.00	-49,804.33	15.6%
7070 · Truck Maintenance				
7071 · Fuel	222.58	20,000.00	-19,777.42	1.1%
7072 · Maintenance	3,120.21	30,000.00	-26,879.79	10.4%
Total 7070 · Truck Maintenance	3,342.79	50,000.00	-46,657.21	6.7%
Total 7000 · Ops & Maintenance Expenses	282,130.94	1,185,500.00	-903,369.06	23.8%
8000 · Salaries and Benefits Expenses				
8001 · Salaries	373,514.90	1,636,798.00	-1,263,283.10	22.8%
8003 · Overtime	22,332.66	125,000.00	-102,667.34	17.9%
8004 · Standby Pay	22,280.62	80,000.00	-57,719.38	27.9%
8005 · Employee Incentives	10,000.00	25,000.00	-15,000.00	40.0%
8006 · Vacation Buyout	24,284.40	80,000.00	-55,715.60	30.4%
8013 · Payroll Taxes	37,105.20	110,000.00	-72,894.80	33.7%
8015 · Payroll Service Processing Fees	2,666.80	8,000.00	-5,333.20	33.3%
8016 · Car Allowance	8,000.00	8,000.00	0.00	100.0%

Sanitary District No.5 of Marin County
Annual Budget vs Actual Expenses
 July 1 through October 10, 2024

	Jul 1 - Oct 10, 24	Budget	\$ Over Budget	% of Budget
8019 · PERS Retirement				
8019.05 · PERS Retirement	71,879.35	312,067.00	-240,187.65	23.0%
8019.06 · PERS Retirement - RBP	0.00	0.00	0.00	0.0%
8019.08 · PERS Retirement - CalPERS UAL	0.00	0.00	0.00	0.0%
Total 8019 · PERS Retirement	71,879.35	312,067.00	-240,187.65	23.0%
8020 · Employee Health				
8020.05 · Employee Health	90,250.60	300,000.00	-209,749.40	30.1%
8021 · Employee Health Deductions	-1,025.22	2,500.00	-3,525.22	-41.0%
8020 · Employee Health - Other	0.00	0.00	0.00	0.0%
Total 8020 · Employee Health	89,225.38	302,500.00	-213,274.62	29.5%
8022 · Retiree Health				
8022.05 · Retiree Health	4,457.73	75,000.00	-70,542.27	5.9%
8022.10 · CERBT/OPEB Annual Arc Contribtn	0.00	140,000.00	-140,000.00	0.0%
8022 · Retiree Health - Other	0.00	0.00	0.00	0.0%
Total 8022 · Retiree Health	4,457.73	215,000.00	-210,542.27	2.1%
8023 · Workers Comp Insurance	39,709.00	56,000.00	-16,291.00	70.9%
Total 8000 · Salaries and Benefits Expenses	705,456.04	2,958,365.00	-2,252,908.96	23.8%
8500 · Other Operating Expenses				
8510 · Data/Alarms/IT Supp & Licensing	28,638.05	100,000.00	-71,361.95	28.6%
8515 · Safety	5,115.21	60,000.00	-54,884.79	8.5%
8520 · Personal Protection/Safety Wear	1,456.59	15,000.00	-13,543.41	9.7%
8530 · Telephone				
8531 · Main Plant Telephones	4,289.46	12,000.00	-7,710.54	35.7%
8532 · Paradise Cove Telephones	668.78	1,500.00	-831.22	44.6%
8533 · Pumps & Lines Telephones	1,622.73	7,000.00	-5,377.27	23.2%
Total 8530 · Telephone	6,580.97	20,500.00	-13,919.03	32.1%
8540 · Utilities				
8541 · Water	2,047.37	11,000.00	-8,952.63	18.6%
8542 · Main Plant Utilities	68,514.11	240,000.00	-171,485.89	28.5%
8543 · Paradise Cove Utilities	7,553.39	35,000.00	-27,446.61	21.6%
8544 · Pump Station Utilities	13,490.38	65,000.00	-51,509.62	20.8%
Total 8540 · Utilities	91,605.25	351,000.00	-259,394.75	26.1%
Total 8500 · Other Operating Expenses	133,396.07	546,500.00	-413,103.93	24.4%
Total Expense	1,257,924.01	5,248,755.00	-3,990,830.99	24.0%
Net Ordinary Income	-799,531.31	2,952,452.00	-3,751,983.31	-27.1%
Other Income/Expense				
Other Expense				
9100 · Capital Expenditures				
9200 · Main Plant Equipment Capital				
9201 · LED Lighting Upgrades	0.00	0.00	0.00	0.0%
9201.1 · M.P. Roll-Up Doors	59,081.00	0.00	59,081.00	100.0%
9201.2 · M.P. Corrosion Protection	19,800.00	0.00	19,800.00	100.0%
9202 · M.P. Drainage	0.00	0.00	0.00	0.0%
9206 · Infl Dry Weather Pump Rplcmnt				
9206.1 · Dry Weather Primary Cover	0.00	0.00	0.00	0.0%
Total 9206 · Infl Dry Weather Pump Rplcmnt	0.00	0.00	0.00	0.0%
9208 · M.P. Chem Feed Trx Pump Rplcmnt	0.00	0.00	0.00	0.0%
9212 · M.P. Headworks				
9212.2 · M.P. Switchgear Upgrade/Imprvmt	0.00	0.00	0.00	0.0%
Total 9212 · M.P. Headworks	0.00	0.00	0.00	0.0%

Sanitary District No.5 of Marin County
Annual Budget vs Actual Expenses
 July 1 through October 10, 2024

	Jul 1 - Oct 10, 24	Budget	\$ Over Budget	% of Budget
9213 · M.P. Digester				
9213.1 · Digester Rehab	0.00	0.00	0.00	0.0%
Total 9213 · M.P. Digester	0.00	0.00	0.00	0.0%
9216 · M.P. Secondary Clarifier				
9216.1 · Scum Removal Project FY22-23	0.00	0.00	0.00	0.0%
9216 · M.P. Secondary Clarifier - Other	0.00	0.00	0.00	0.0%
Total 9216 · M.P. Secondary Clarifier	0.00	0.00	0.00	0.0%
9217 · SD5 Shop Rplcmnt /Ops Control				
9217.1 · FY23-24 Shop Rehab	0.00	0.00	0.00	0.0%
Total 9217 · SD5 Shop Rplcmnt /Ops Control	0.00	0.00	0.00	0.0%
9229.8 · Vehicle Replacement	216,076.20	0.00	216,076.20	100.0%
9200 · Main Plant Equipment Capital - Other	0.00	0.00	0.00	0.0%
Total 9200 · Main Plant Equipment Capital	294,957.20	0.00	294,957.20	100.0%
9300 · Pumps & Lines Capital				
9301 · Tiburon Sewer Line Rehab Prog	172,334.00	0.00	172,334.00	100.0%
9303 · CCTV Sewer Project	0.00	0.00	0.00	0.0%
9304 · Belvedere Sewer Line Rehab Prog	0.00	0.00	0.00	0.0%
9305 · Valve/Wet Well Replacements				
9305.2 · Tiburon Wet Well Rehab	0.00	0.00	0.00	0.0%
Total 9305 · Valve/Wet Well Replacements	0.00	0.00	0.00	0.0%
9306 · PS Pump & Valve Replacements	0.00	0.00	0.00	0.0%
9309 · BPS #1 Generator Replcmnt	8,987.00	0.00	8,987.00	100.0%
9313 · Manholes/Rodholes	24,106.96	0.00	24,106.96	100.0%
9314.01 · SR Ave Diverter Project	0.00	0.00	0.00	0.0%
9300 · Pumps & Lines Capital - Other	0.00	0.00	0.00	0.0%
Total 9300 · Pumps & Lines Capital	205,427.96	0.00	205,427.96	100.0%
9400 · Paradise Cove Capital				
9406 · P.C. Plant Grit Removal	0.00	0.00	0.00	0.0%
9407 · P.C. Pump Replacement	0.00	0.00	0.00	0.0%
9408 · P.C. Access Rd Imprvmnts	0.00	0.00	0.00	0.0%
9400 · Paradise Cove Capital - Other	0.00	0.00	0.00	0.0%
Total 9400 · Paradise Cove Capital	0.00	0.00	0.00	0.0%
9500 · Undesignated Capital				
9510 · Undesignated Cap - M.P.	0.00	0.00	0.00	0.0%
9520 · Undesignated Cap - P.C. Plant	0.00	0.00	0.00	0.0%
9530 · Undesignated Cap - P & L	0.00	0.00	0.00	0.0%
Total 9500 · Undesignated Capital	0.00	0.00	0.00	0.0%
9100 · Capital Expenditures - Other	0.00	0.00	0.00	0.0%
Total 9100 · Capital Expenditures	500,385.16	0.00	500,385.16	100.0%
9700 · Debt Service				
9701 · Zion Bank Loan- Principal	0.00	0.00	0.00	0.0%
9702 · Zion Bank Loan - Interest	0.00	0.00	0.00	0.0%

Sanitary District No.5 of Marin County Annual Budget vs Actual Expenses July 1 through October 10, 2024

	Jul 1 - Oct 10, 24	Budget	\$ Over Budget	% of Budget
9730 · Debt Service - MPR Project				
9730.01 · Zion Loan - Principal	625,000.00	0.00	625,000.00	100.0%
9730.02 · Zion Loan - Interest	67,642.01	0.00	67,642.01	100.0%
9731 · Debt Service MPR Bond Principal	0.00	0.00	0.00	0.0%
9732 · Debt Service MPR Bond Interest	0.00	0.00	0.00	0.0%
9734 · MPR Refi - Principal	0.00	0.00	0.00	0.0%
9735 · MPR Refi - Interest	0.00	0.00	0.00	0.0%
Total 9730 · Debt Service - MPR Project	<u>692,642.01</u>	<u>0.00</u>	<u>692,642.01</u>	<u>100.0%</u>
Total 9700 · Debt Service	<u>692,642.01</u>	<u>0.00</u>	<u>692,642.01</u>	<u>100.0%</u>
Total Other Expense	<u>1,193,027.17</u>	<u>0.00</u>	<u>1,193,027.17</u>	<u>100.0%</u>
Net Other Income	<u>-1,193,027.17</u>	<u>0.00</u>	<u>-1,193,027.17</u>	<u>100.0%</u>
Net Income	<u>-1,992,558.48</u>	<u>2,952,452.00</u>	<u>-4,945,010.48</u>	<u>-67.5%</u>



Summary Statement

September 30, 2024

Page 1 of 4

Investor ID: CA-01-0195

0000182-0000707 PDF 697362

**Sanitary District No. 5 of Marin County
PO Box 227
Tiburon, CA 94920**

California CLASS

California CLASS

Average Monthly Yield: 5.2597%

		Beginning Balance	Contributions	Withdrawals	Income Earned	Income Earned YTD	Average Daily Balance	Month End Balance
CA-01-0195-0001	Emergency Replacement Fund	0.00	1,000,000.00	0.00	549.76	549.76	133,351.79	1,000,549.76
CA-01-0195-0002	CalPERS UAL Fund	0.00	139,951.00	0.00	115.42	115.42	27,994.05	140,066.42
TOTAL		0.00	1,139,951.00	0.00	665.18	665.18	161,345.84	1,140,616.18



Emergency Replacement Fund

Account Summary

Average Monthly Yield: 5.2597%

	Beginning Balance	Contributions	Withdrawals	Income Earned	Income Earned YTD	Average Daily Balance	Month End Balance
California CLASS	0.00	1,000,000.00	0.00	549.76	549.76	133,351.79	1,000,549.76

Transaction Activity

Transaction Date	Transaction Description	Contributions	Withdrawals	Balance	Transaction Number
09/23/2024	Contribution	1.00			6508
09/27/2024	Contribution	999,999.00			6544
09/30/2024	Income Dividend Reinvestment	549.76			
09/30/2024	Ending Balance			1,000,549.76	



Account Statement

September 30, 2024

Page 3 of 4

Account Number: CA-01-0195-0002

CalPERS UAL Fund

Account Summary

Average Monthly Yield: 5.2597%

	Beginning Balance	Contributions	Withdrawals	Income Earned	Income Earned YTD	Average Daily Balance	Month End Balance
California CLASS	0.00	139,951.00	0.00	115.42	115.42	27,994.05	140,066.42

Transaction Activity

Transaction Date	Transaction Description	Contributions	Withdrawals	Balance	Transaction Number
09/25/2024	Contribution	139,951.00			6519
09/30/2024	Income Dividend Reinvestment	115.42			
09/30/2024	Ending Balance			140,066.42	



California CLASS

California CLASS

Date	Dividend Rate	Daily Yield
09/01/2024	0.000000000	5.4035%
09/02/2024	0.000000000	5.4035%
09/03/2024	0.000146793	5.3787%
09/04/2024	0.000147382	5.3942%
09/05/2024	0.000147628	5.4032%
09/06/2024	0.000442686	5.4008%
09/07/2024	0.000000000	5.4008%
09/08/2024	0.000000000	5.4008%
09/09/2024	0.000147346	5.3929%
09/10/2024	0.000147355	5.3932%
09/11/2024	0.000147286	5.3907%
09/12/2024	0.000146932	5.3777%
09/13/2024	0.000440367	5.3725%
09/14/2024	0.000000000	5.3725%
09/15/2024	0.000000000	5.3725%
09/16/2024	0.000147118	5.3845%
09/17/2024	0.000147765	5.4082%
09/18/2024	0.000147687	5.4053%
09/19/2024	0.000144865	5.3021%
09/20/2024	0.000414282	5.0543%
09/21/2024	0.000000000	5.0543%
09/22/2024	0.000000000	5.0543%
09/23/2024	0.000137865	5.0459%
09/24/2024	0.000137691	5.0395%
09/25/2024	0.000137589	5.0357%
09/26/2024	0.000137358	5.0273%
09/27/2024	0.000412029	5.0267%
09/28/2024	0.000000000	5.0267%
09/29/2024	0.000000000	5.0267%
09/30/2024	0.000137730	5.0409%

Performance results are shown net of all fees and expenses and reflect the reinvestment of dividends and other earnings. Many factors affect performance including changes in market conditions and interest rates and in response to other economic, political, or financial developments. Investment involves risk including the possible loss of principal. No assurance can be given that the performance objectives of a given strategy will be achieved. **Past performance is no guarantee of future results. Any financial and/or investment decision may incur losses.**

Sanitary District No.5 of Marin County
Comparative Balance Sheet
As of October 10, 2024

	Oct 10, 24	Sep 10, 24	\$ Change
ASSETS			
Current Assets			
Checking/Savings			
JP Morgan Chase - Primary 7399	-45,791.01	349,223.99	-395,015.00
JP Morgan Chase - Payroll 7506	99,683.62	82,282.60	17,401.02
JP Morgan Chase - Transfer 7522	1,146,254.28	207,254.28	939,000.00
Local Agency Investment Fund			
SD5 CalPERS Retirement Trust	71,951.00	71,951.00	0.00
SD5 Operating Reserve	61,853.05	1,200,853.05	-1,139,000.00
SD5 Operating	2,097,861.76	3,097,861.76	-1,000,000.00
SD5 Disaster Recovery Fund	1,000,000.00	1,000,000.00	0.00
SD5 Capital & CIP Reserve	9,725,065.99	9,725,065.99	0.00
Total Local Agency Investment Fund	<u>12,956,731.80</u>	<u>15,095,731.80</u>	<u>-2,139,000.00</u>
Total Checking/Savings	<u>14,156,878.69</u>	<u>15,734,492.67</u>	<u>-1,577,613.98</u>
Accounts Receivable			
Accounts Receivable	350,900.13	296,690.31	54,209.82
Total Accounts Receivable	<u>350,900.13</u>	<u>296,690.31</u>	<u>54,209.82</u>
Other Current Assets	<u>101,229.39</u>	<u>101,229.39</u>	<u>0.00</u>
Total Current Assets	<u>14,609,008.21</u>	<u>16,132,412.37</u>	<u>-1,523,404.16</u>
Fixed Assets	<u>18,809,155.30</u>	<u>18,809,155.30</u>	<u>0.00</u>
TOTAL ASSETS	<u>33,418,163.51</u>	<u>34,941,567.67</u>	<u>-1,523,404.16</u>
LIABILITIES & EQUITY			
Liabilities	5,221,419.87	6,289,310.42	-1,067,890.55
Equity	<u>28,196,743.64</u>	<u>28,652,257.25</u>	<u>-455,513.61</u>
TOTAL LIABILITIES & EQUITY	<u>33,418,163.51</u>	<u>34,941,567.67</u>	<u>-1,523,404.16</u>

Overtime hours



Check date

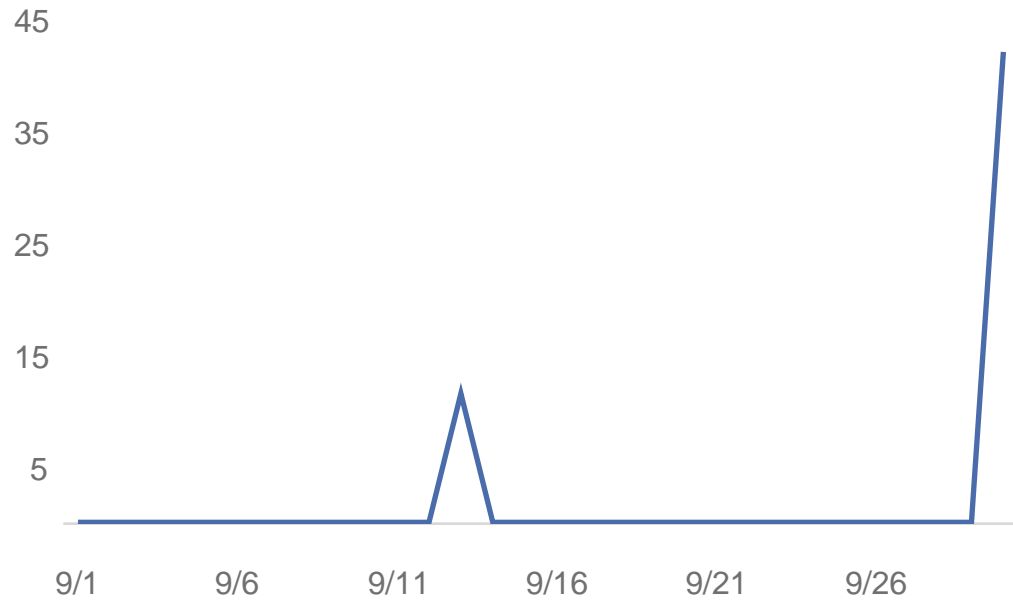

Sep 1, 2024 - Sep 30, 2024

● My Company

53.5 hrs

Overtime amounts



Check date

\$4.5k

\$3.5k

\$2.5k

\$1.5k

\$500

Sep 1, 2024 - Sep 30, 2024

● My Company

\$5,374.07

9/1

9/6

9/11

9/16

9/21

9/26



Check date	Overtime amount
9/1	\$0
9/2	\$0
9/3	\$0
9/4	\$0
9/5	\$0
9/6	\$0
9/7	\$0
9/8	\$0
9/9	\$0
9/10	\$0
9/11	\$0
9/12	\$1,200
9/13	\$0
9/14	\$0
9/15	\$0
9/16	\$0
9/17	\$0
9/18	\$0
9/19	\$0
9/20	\$0
9/21	\$0
9/22	\$0
9/23	\$0
9/24	\$0
9/25	\$0
9/26	\$0
9/27	\$0
9/28	\$0
9/29	\$0
9/30	\$5,374.07

Labor cost ⓘ



Check date

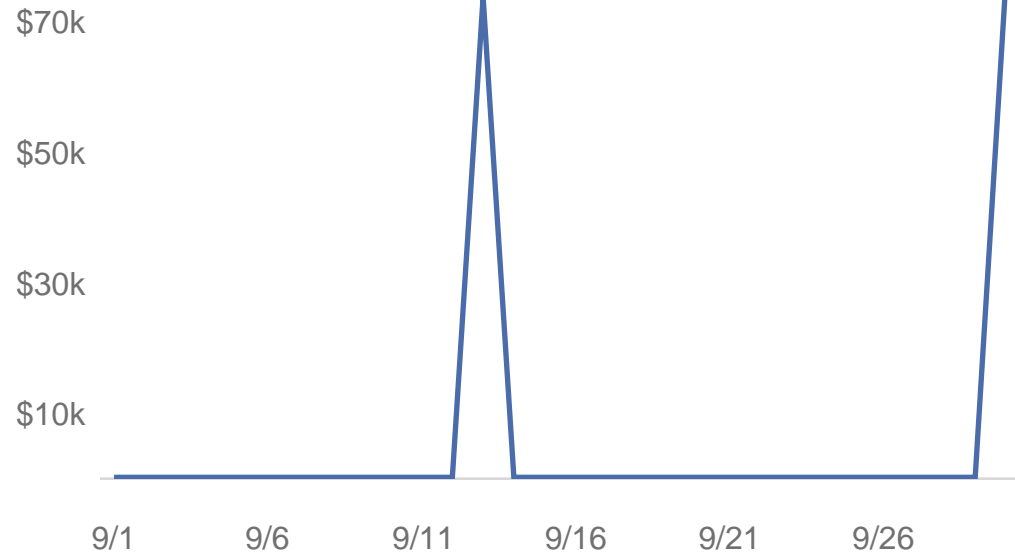

Sep 1, 2024 - Sep 30, 2024

● My Company

\$149,673.77

Full name	Overtime amounts	Overtime hours
Alvarez, Joel		
Balf, Abigail	960.10	13.50
Bilsborough Sr., Chad E		
Collodi, Pete		
Cottrell III, Rulon K	1370.99	11.00
LaTorre, Daniel P	1959.36	17.00
Rosser, John M	527.00	5.00
Rubio, Antonio		
Salazar, Ignacio G	277.62	4.00
Screechfield-Lablue, Pierce L		
Triola, Joseph	279.00	3.00
	5374.07	53.50

Overtime hours



Check date

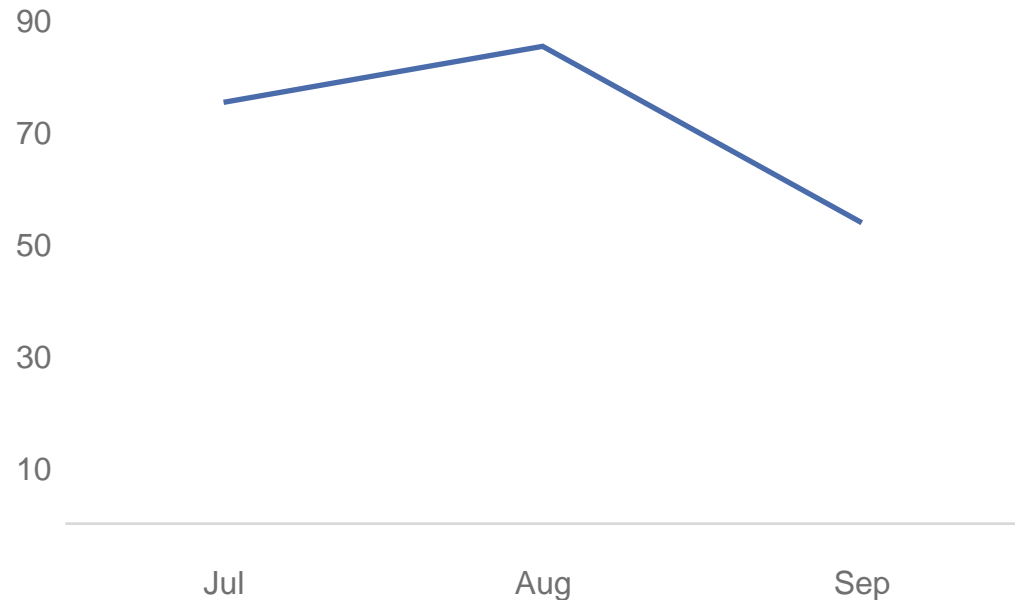

Jul 1, 2024 - Sep 30, 2024

● My Company

213.5 hrs

Overtime amounts



Check date

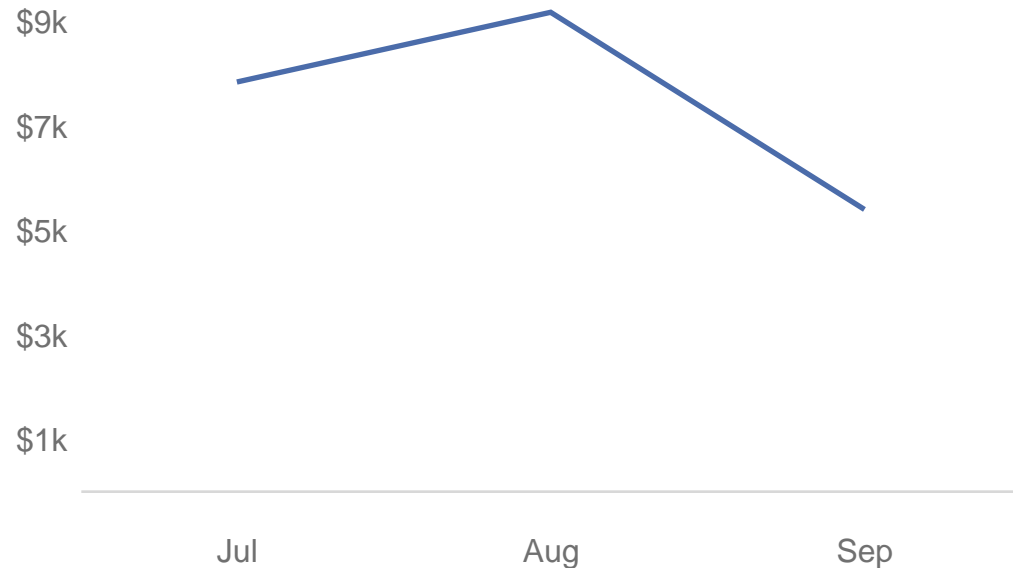

Jul 1, 2024 - Sep 30, 2024

● My Company

\$22,332.66

Labor cost ⓘ



Check date

Jul 1, 2024 - Sep 30, 2024

\$250k

● My Company

\$505,552.49

\$150k

\$50k

Jul

Aug

Sep

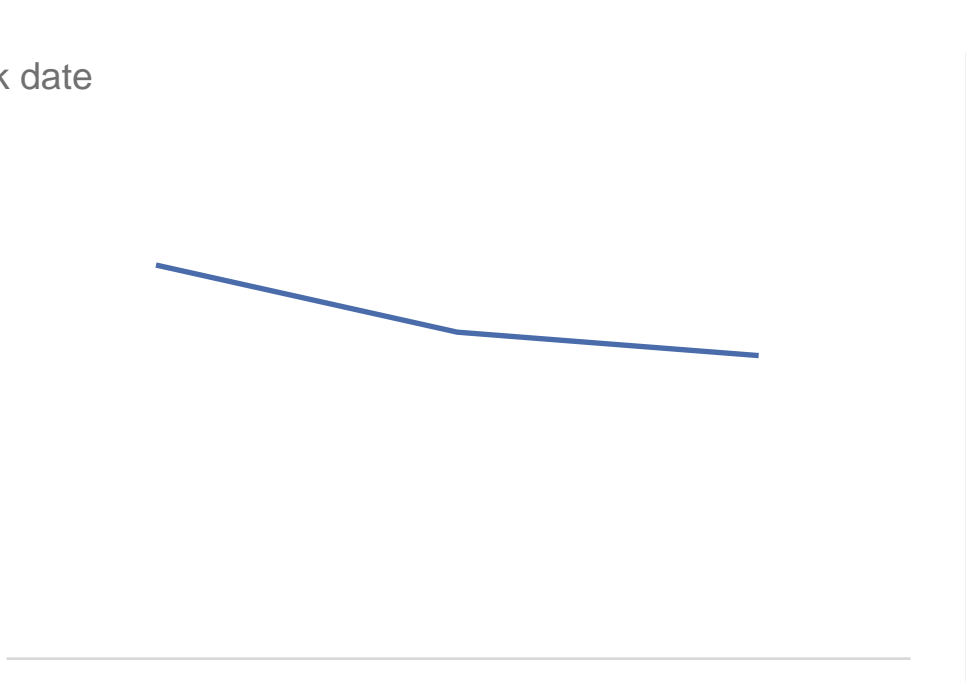

Full name	Overtime amounts	Overtime hours
Alvarez, Joel		
Balf, Abigail	1307.13	18.50
Bilsborough Sr., Chad E	1798.00	16.50
Collodi, Pete	484.66	6.00
Cottrell III, Rulon K	3448.24	27.00
LaTorre, Daniel P	7385.28	62.00
Rosser, John M	1906.50	19.00
Rubio, Antonio		
Salazar, Ignacio G	277.62	4.00
Screechfield-Lablue, Pierce L	377.73	5.00
Triola, Joseph	5347.50	55.50
	22332.66	213.50

CASH REQUIREMENTS

CASH REQUIRED FOR NEGOTIABLE CHECKS &/OR ELECTRONIC FUNDS TRANSFERS (EFT) FOR CHECK DATE 09/13/24: \$64,468.36

IMPORTANT COVID-19 INFORMATION: If you filed IRS Form 7200, please notify your Paychex representative to avoid owing a balance at the end of the quarter and ensure your Form 941 is accurate.

TRANSACTION SUMMARY

SUMMARY BY TRANSACTION TYPE -	TOTAL ELECTRONIC FUNDS TRANSFER (EFT)	64,468.36
	CASH REQUIRED FOR NEGOTIABLE CHECKS &/OR EFT	64,468.36
	TOTAL REMAINING DEDUCTIONS / WITHHOLDINGS / LIABILITIES	9,066.90
	CASH REQUIRED FOR CHECK DATE 09/13/24	<u>73,535.26</u>

TRANSACTION DETAIL

ELECTRONIC FUNDS TRANSFER - *Your financial institution will initiate transfer to Paychex at or after 12:01 A.M. on transaction date.*

<u>TRANS. DATE</u>	<u>BANK NAME</u>	<u>ACCOUNT NUMBER</u>	<u>PRODUCT</u>	<u>DESCRIPTION</u>		BANK DRAFT AMOUNTS & OTHER TOTALS
09/13/24	CHASE BANK, NA	xxxxxxxxxxxxx506	Direct Deposit	Net Pay Allocations	43,474.51	43,474.51
09/13/24	CHASE BANK, NA	xxxxxxxxxxxxx506	Taxpay®	Employee Withholdings		
				Social Security	3,486.79	
				Medicare	962.28	
				Fed Income Tax	8,522.32	
				CA Income Tax	3,573.39	
				Total Withholdings	<u>16,544.78</u>	
				Employer Liabilities		
				Social Security	3,486.80	
				Medicare	962.27	
				Total Liabilities	<u>4,449.07</u>	20,993.85
				EFT FOR 09/13/24		64,468.36
				TOTAL EFT		64,468.36

REMAINING DEDUCTIONS / WITHHOLDINGS / LIABILITIES - *Paychex does not remit these funds. You must ensure accurate and timely payment of applicable items.*

<u>TRANS. DATE</u>	<u>BANK NAME</u>	<u>ACCOUNT NUMBER</u>	<u>PRODUCT</u>	<u>DESCRIPTION</u>		<u>TOTAL</u>
09/13/24	Refer to your records for account Information		Payroll	Employee Deductions		
				401A Member Contribu	4,683.03	
				Calpers 457B Roth	1,333.00	
				Calpers 457B TRDL	2,746.67	
				Med 125	170.87	

CASH REQUIREMENTS

CASH REQUIRED FOR NEGOTIABLE CHECKS &/OR ELECTRONIC FUNDS TRANSFERS (EFT) FOR CHECK DATE 09/13/24: \$64,468.36

REMAINING DEDUCTIONS / WITHHOLDINGS / LIABILITIES (cont.) - Paychex does not remit these funds. You must ensure accurate and timely payment of applicable items.

<u>TRANS. DATE</u>	<u>BANK NAME</u>	<u>ACCOUNT NUMBER</u>	<u>PRODUCT</u>	<u>DESCRIPTION</u>	<u>TOTAL</u>
09/13/24	Refer to your records for account	Information	Payroll	Employee Deductions (cont.)	
				Med FSA EE Pretax	133.33
				Total Deductions	9,066.90
TOTAL REMAINING DEDUCTIONS / WITHHOLDINGS / LIABILITIES					9,066.90

PAYCHEX WILL MAKE THESE TAX DEPOSIT(S) ON YOUR BEHALF - This information serves as a record of payment.

<u>DUE DATE</u>	<u>PRODUCT</u>	<u>DESCRIPTION</u>	
09/18/24	Taxpay®	FED IT PMT Group	17,420.46
09/18/24	Taxpay®	CA IT PMT Group	3,573.39

CASH REQUIREMENTS

CASH REQUIRED FOR NEGOTIABLE CHECKS &/OR ELECTRONIC FUNDS TRANSFERS (EFT) FOR CHECK DATE 09/30/24: \$67,210.10

IMPORTANT COVID-19 INFORMATION: If you filed IRS Form 7200, please notify your Paychex representative to avoid owing a balance at the end of the quarter and ensure your Form 941 is accurate.

TRANSACTION SUMMARY

SUMMARY BY TRANSACTION TYPE -	TOTAL ELECTRONIC FUNDS TRANSFER (EFT)	67,210.10
	CASH REQUIRED FOR NEGOTIABLE CHECKS &/OR EFT	67,210.10
	TOTAL REMAINING DEDUCTIONS / WITHHOLDINGS / LIABILITIES	8,928.41
	CASH REQUIRED FOR CHECK DATE 09/30/24	<u>76,138.51</u>

TRANSACTION DETAIL

ELECTRONIC FUNDS TRANSFER - *Your financial institution will initiate transfer to Paychex at or after 12:01 A.M. on transaction date.*

<u>TRANS. DATE</u>	<u>BANK NAME</u>	<u>ACCOUNT NUMBER</u>	<u>PRODUCT</u>	<u>DESCRIPTION</u>		BANK DRAFT AMOUNTS & OTHER TOTALS
09/27/24	CHASE BANK, NA	xxxxxxxxxxxxx506	Direct Deposit	Net Pay Allocations	45,419.73	45,419.73
09/27/24	CHASE BANK, NA	xxxxxxxxxxxxx506	Taxpay®	Employee Withholdings		
				Social Security	3,361.13	
				Medicare	1,002.45	
				Fed Income Tax	9,192.95	
				CA Income Tax	3,870.23	
				Total Withholdings	<u>17,426.76</u>	
				Employer Liabilities		
				Social Security	3,361.14	
				Medicare	1,002.47	
				Total Liabilities	<u>4,363.61</u>	21,790.37
				EFT FOR 09/27/24		67,210.10
				TOTAL EFT		67,210.10

REMAINING DEDUCTIONS / WITHHOLDINGS / LIABILITIES - *Paychex does not remit these funds. You must ensure accurate and timely payment of applicable items.*

<u>TRANS. DATE</u>	<u>BANK NAME</u>	<u>ACCOUNT NUMBER</u>	<u>PRODUCT</u>	<u>DESCRIPTION</u>		<u>TOTAL</u>
09/30/24	Refer to your records for account	Information	Payroll	Employee Deductions		
				401A Member Contribu	4,544.54	
				Calpers 457B Roth	1,333.00	
				Calpers 457B TRDL	2,746.67	
				Med 125	170.87	

CASH REQUIREMENTS

CASH REQUIRED FOR NEGOTIABLE CHECKS &/OR ELECTRONIC FUNDS TRANSFERS (EFT) FOR CHECK DATE 09/30/24: \$67,210.10

REMAINING DEDUCTIONS / WITHHOLDINGS / LIABILITIES (cont.) - *Paychex does not remit these funds. You must ensure accurate and timely payment of applicable items.*

<u>TRANS. DATE</u>	<u>BANK NAME</u>	<u>ACCOUNT NUMBER</u>	<u>PRODUCT</u>	<u>DESCRIPTION</u>	<u>TOTAL</u>
09/30/24	Refer to your records for account	Information	Payroll	Employee Deductions (cont.)	
				Med FSA EE Pretax	133.33
				Total Deductions	8,928.41
TOTAL REMAINING DEDUCTIONS / WITHHOLDINGS / LIABILITIES					8,928.41

PAYCHEX WILL MAKE THESE TAX DEPOSIT(S) ON YOUR BEHALF - *This information serves as a record of payment.*

<u>DUE DATE</u>	<u>PRODUCT</u>	<u>DESCRIPTION</u>	
10/04/24	Taxpay®	FED IT PMT Group	17,920.14
10/04/24	Taxpay®	CA IT PMT Group	3,870.23

November 2024

November 2024							December 2024						
Su	Mo	Tu	We	Th	Fr	Sa	Su	Mo	Tu	We	Th	Fr	Sa
3	4	5	6	7	8	9	1	2	3	4	5	6	7
10	11	12	13	14	15	16	8	9	10	11	12	13	14
17	18	19	20	21	22	23	15	16	17	18	19	20	21
24	25	26	27	28	29	30	22	23	24	25	26	27	28
							29	30	31				

SUNDAY	MONDAY	TUESDAY	WEDNESDAY	THURSDAY	FRIDAY	SATURDAY
Oct 27	28	29	30	31	Nov 1	2
3	4	5	6 JK in Check Run	7 JK in check run	8	9
10	11	12	13	14 JK in audit work 9:30am CIP Committee Meeting (2001 Paradise Drive) 10:30am Finance Committee Meeting	15	16
17	18 JK in audit work	19 Potential Special Meeting? Cancel Regular Meeting on 21st	20	21 Regular Board Meeting- Cancel?	22	23
24	25 TR off Admin	26 TR off Admin	27 Thanksgiving- Observed Holiday	28 Day after Thanskiving- Observed Holiday	29	30

December 2024

December 2024							January 2025						
Su	Mo	Tu	We	Th	Fr	Sa	Su	Mo	Tu	We	Th	Fr	Sa
1	2	3	4	5	6	7	5	6	7	1	2	3	4
8	9	10	11	12	13	14	12	13	14	15	16	17	18
15	16	17	18	19	20	21	19	20	21	22	23	24	25
22	23	24	25	26	27	28	26	27	28	29	30	31	
29	30	31											

SUNDAY	MONDAY	TUESDAY	WEDNESDAY	THURSDAY	FRIDAY	SATURDAY
Dec 1	2	3	4 JK in for check run	5 JK in for check run	6	7
8	9	10	11	12 9:30am CIP Committee Meeting (2001 Paradise Drive) 10:30am Finance Committee Meeting (2001 Paradise Drive)	13	14
15	16	17 JK in for Finance Work	18 JK in for finance	19 5:00pm Regular Board Meeting (2001 Paradise Drive Tiburon CA 94920) - HR	20	21
22	23 TR off Admin	24 TR off Admin	25 Christmas Day- Observed Holiday	26 TR off Holiday Owed	27	28
29	30 TR off Holiday Owed	31 TR off Holiday Owed	Jan 1, 25	2	3	4

Sanitary District No. 5 of Marin County



District Management Report September 2024

Contents:

- Transmittal Memo
- Financial/Budgetary
- HR & Personnel
- Business Administration
- Collection System Performance
- Treatment Plant Performance – Paradise Cove
- Treatment Plant Performance – Main Plant
- Pollution Prevention Activities
- Continuing Education & Safety Training
- Capital Improvement Projects

Transmittal Memo

Date: October 17, 2024
To: Board of Directors
From: Tony Rubio, District Manager
Subject: Management Report for September 2024

Fiscal Status

Period Covered: July 1, 2023 –October 10, 2024
Percent of Fiscal Year: 25%
Percent of Budgeted Income to Date: 5.6%
Percent of Budgeted Expenditures to Date: 24% (operating only)

Personnel

Separations: None
New Hires: 1
Promotions: None
Recruitment Activities: None

Regulatory Compliance

MP Collection System WDR Compliance: Full Compliance with all regulations
PC Collection System WDR Compliance: Full Compliance with all regulations
MP NPDES Permit Compliance: Full Compliance with all regulations
PC NPDES Permit Compliance: Full Compliance with all regulations
BAAQMD Compliance: Full Compliance with all regulations
Significant Comments: None

Summary of Operational Highlights are on the following pages.

Significant Events for the Month of September 2024 Include:

Financial/Budgetary/Business Administration

- Bookkeeper Jill Kalehua from DMMS (Daily Money Management Services) in 4 days a month to perform AR/AP functions for office.
- Business Server file clean up ongoing- Scans Folders review and renaming underway
- Fiscal year 2023/2024 Final Audit underway expecting November or December final audit- awaiting GASB 75 report.

HR and Personnel

- Employee portal setup through website, working on populating portal for staff and board member use on going

Continuing Education, Safety Training, Pollution Prevention Activities

- Work with DKF solutions on District safety program updates on-going.
- Completed Chemical Hygiene CBT Policy (computer based training)
- Fire Prevention Policy currently under review
- Establishing CBT safety training calendar for monthly staff safety policy refresher trainings
- Staff attended monthly Public Education Meeting.

Collection System Performance

Main Plant Tiburon/Belvedere/Paradise Cove

- Tiburon Station #4 Control Panel relocation and wet well rehabilitation work completed
- Rodder and Vactor preventative maintenance works has been scheduled and is underway.

Treatment Plant Performance

Paradise Cove WWTP

- No Spill Report for Paradise Cove Collection System

Tiburon Main WWTP:

- Submitted August 2024 Monthly SMR and DMR to the RWQCB on CIWQS.
- DW tanks remain out of service for scum skimmer installation 1 has been installed -2nd scheduled to be completed at end of month.

- Odor Control system plumbing repairs performed and new recirculation pump ordered for caustic side.
- File Storage Control Building Replacement underway

Capital Improvement Projects

- 2025 Sewer Rehab Design Completed and Project ready to bid
- Cove Road MCC and Generator replacement project design close to 90%
- Digester Cleaning and Rehab project tentative start date late October mobilization
- Research project on Plant Parcel for potential solar project underway

Glossary of Terms

- **B.O.D. (Biochemical Oxygen Demand):** Measurement of the effluent's capacity to consume dissolved oxygen to stabilize all remaining organic matter. The permit limits for our effluent for discharge into San Francisco bay require that we remove 85% influent B.O.D. and meet a weekly average of less than 45mg/l and a monthly average of less than 30 mg/l B.O.D.
- **TSS (Total Suspended Solids):** Measurement of suspended solids in the effluent. Our permit requires that we remove at least 85% of the influent TSS and that the effluent limit is less than 45 mg/l as a weekly average and less than 30 mg/l as a monthly average.
- **Chlorine Residual:** The plant effluent is disinfected with hypochlorite (chlorine "bleach") and then the residual chlorine is neutralized with sodium bisulfite to protect the bay. The effluent chlorine residual limit is 0.0 mg/l which we monitor continuously.
- **pH:** pH is a measurement of acidity with pH 7.0 being neutral and higher pH values being basic and lower pH values being acidic. Our permit effluent pH must stay within the range of 6.0-9.0, which we monitor continuously.
- **Coliform:** Coliform bacteria are the indicator organism for determination of the efficiency of the disinfection process. The lab culture samples of our effluent and the presence of coliform is an indication that pathogenic organisms may be present. This is reported as MPN/100 (number of coliform bacteria in 100 milliliters sample).
- **Flow Through Bioassay:** A 96 hour test in which we test the toxicity of our effluent to tiny fish (sticklebacks) in a flow through tank to determine the survivability under continuous exposure to our effluent. Our permit requires that we maintain a 90th percentile survival of at least 70% and an 11 sample median survival of at least 90%. In layman's terms, this means that out of the last 11 samples only one bioassay may fall below 70% survival and the middle value when all 11 samples are placed in numerical order must be at least 90%.
- **Metals Analysis:** Our permit requires that we analyze our effluent for many different metals on a monthly basis. We have permit limits for some metals. The metals are stated as a daily max and a monthly average limit. The daily max limit is the number we cannot exceed on any sample and the monthly average applies to all samples collected in any month (although usually we are only required to take one).
- **F.O.G. (Fats, oils and grease):** Quarterly we are required to monitor our effluent for Fats, Oils and Grease.

Glossary of terms continued...

- **Headworks:** The point where all raw wastewater enters the treatment plant. In this building wastewater goes through 3 grinders to grind up all large objects that could possibly damage our influent and sludge pumps further down the treatment process.
- **Primary Sedimentation:** The next treatment process is a physical treatment process where solids that settle or float are removed and sent to the digesters for further processing.
- **Activated Sludge:** Next is the activate sludge process. This process is a biological wastewater treatment process that uses microorganisms to speed up the decomposition of wastes. When activated sludge is added to wastewater, the microorganisms feed and grow on waste particles in the wastewater. As the organisms grow and reproduce, more and more waste is removed, leaving the wastewater partially cleaned. To function efficiently, the mass of organisms needs a steady balance of food and oxygen. These tasks are closely monitored by the operations staff.
- **Secondary Clarification:** Next is secondary clarification, like primary sedimentation/clarification, this also is a physical treatment process where solids that settle or float are removed and sent to the next treatment process. The difference between Secondary Clarification and primary sedimentation is that the solids removed from the secondary clarifiers goes to 2 places. Some goes to waste to the DAFT and some goes back to the activated sludge process for further treatment. (*Microorganisms must be returned to the activated sludge process to keep an equal balance of food and microorganisms*).
- **DAFT (dissolved air floatation thickener):** Next is the DAFT. The dissolved air floatation thickening process uses air bubbles to thicken WAS(waste active sludge) solids removed from the secondary clarifier, by floating solids to the tank surface, where they are removed and sent to the digesters for final processing.
- **Sludge Digestion:** In the anaerobic digestion process, all the organic material removed from the primary sedimentation tanks and DAFT's are digested by anaerobic bacteria. The end products are methane, carbon dioxide, water and neutralized organic matter.
- **Solids Handling:** This is the process where all the neutralized sludge from the digester is finally treated. Sludge from the digester is pumped to the screw press where it is conditioned with a polymer (chemical that reacts with the sludge to remove the water from the sludge and bind the sludge particles together) in order to dewater the sludge and produce a dry cake for final disposal to the Redwood landfill.

Glossary of terms continued...

- **Disinfection:** This is the end point for the wastewater- at this point wastewater flows through the chlorine contact tank. This contact tank allows for enough contact time for chlorine solution to disinfect the wastewater. Sodium bisulfite is introduced at the end of the tank to neutralize any residual chlorine to protect the bay.
- **MLSS (mixed liquor suspended solids):** Suspended solids in the mixed liquor of an aeration tank measured in mg/l
- **MCRT (mean cell resident time):** An expression of the average time that a microorganism will spend in the activated sludge process.
- **SVI (sludge volume index):** This is a calculation used to indicate the settling ability of activated sludge in the secondary clarifier.
- **RAS (return activated sludge):** The purpose of returning activated sludge, is to maintain a sufficient concentration of activated sludge in the aeration tank.
- **WAS (waste activated sludge):** To maintain a stable process, the amount of solids added each day to the activated sludge process are removed as WAS. We track this by our MCRT which averages 3 days
- **TWAS (thickened waste activated sludge):** The WAS is thickened in the DAFT and the thickened sludge is then pumped to the digester.
- **MPN (most probable number):** Concentrations of total coliform bacteria are reported as the most probable number. The MPN is not the absolute count of the bacteria but a statistical estimate of their concentration.
- **Bio-solids:** Anaerobic digested sludge is pumped to a screw press where excess water is removed to reduce the volume (and weight) thus producing an end result called bio-solids.
- **Polymer:** Organic polymers are added to digested sludge to bring out the formation of larger particles by bridging to improve processing.

Wastewater Acronyms

ACWA	Assoc of California Water Agencies	APWA	American Public Works Association
AWWA	American Water Works Association	BAAQMD	Bay Area Air Quality Management District
BACWA	Bay Area Clean Water Agencies	BAPPG:	Bay Area Pollution Prevention Group
CASA	California Association of Sanitation Agencies	CSDA	California Special Districts Association
CSRMA:	California Sanitation Risk Management Authority	CAAQS	California Ambient Air Quality Standard
CalARP	California Accidental Release Prevention Program	CARB	California Air Resources Board
CDO	Cease and Desist Order	CECs	Constituents of Emerging Concern
CEQA	California Environmental Quality Act	CIWQS	California Integrated Water Quality System
CFR	Code of Federal Regulations	CMOM	Capacity, Management, Operation and Maintenance
CIWMB	California Integrated Waste Management Board		
CIWQS	California Integrated Water Quality System	CPUC	California Public Utilities Commission
CSO	Combined Sewer Overflow	CTR	California Toxics Rule
CWA	Clean Water Act	CWAP	Clean Water Action Plan
CWARA	Clean Water Authority Restoration Act	CWEA	California Water Environment Association
DHS	Dept. of Health Services	DTSC	Dept. of Toxic Substances Control
EBEP	Enclosed Bays and Estuaries Plan	EDW	Effluent Dominated Water body
EIS/EIR	Environmental Impact Statement/Report	EPA	Environmental Protection Agency
ERAF	Educational Reserve Augmentation Fund	ESMP	Electronic Self-Monitoring Report
FOG	Fats, Oils and Grease	GASB	Government Accounting Standards Board
ISWP	Inland Surface Waters Plan	JPA	Joint Powers Authority
LAFCO	Local Agency Formation Commission	LOCC	League of California Cities
MACT	Maximum Achievable Control Technology (air controls)	MCL	Maximum Contaminant Level
MMP	Mandatory Minimum Penalty	MOU	Memorandum of Understanding
MUN	Municipal Drinking Water Use	NACWA	National Association of Clean Water Agencies
NGOs	Non-Governmental Organizations	NOX	Nitrogen Oxides
NPDES	Nat'l Pollutant Discharge Elimination System	NRDC	Natural Resources Defense Council
NTR	National Toxics Rule	OWP:	Office of Water Programs
OSHA:	Occupational Safety and Health Administration	PCBs	Poly Chlorinated Biphenyls
POTWs	Publicly Owned Treatment Works	PPCPs	Pharmaceutical and personal Care Products
QA/QC	Quality Assurance / Quality Control	Region	IX Western Region of EPA (CA, AZ, NV & HI)
RFP	Request For Proposals	RMP	Risk Management Program
RFQ	Request For Qualifications	RWQCB	Regional Water Quality Control Board
SEP	Supplementary Environmental Projects	SIP	State Implementation Policy (CTR/NTR criteria)
SFEI:	San Francisco Estuary Institute	SRF	State Revolving Fund
SSO	Sanitary Sewer Overflow	SSMP	Sewer System Management Plan
SWRCB	State Water Resources Control Board	TMDL	Total Maximum Daily Load
WDR	Waste Discharge Requirements	WEF	Water Environment Federation
WERF	Water Environment Research Foundation	WET	Whole Effluent Toxicity or Waste Extraction Test
WMI	Watershed Management Initiative	WRFP	Water Recycling Funding Program
WRDA	Water Resource Development Act	WWTP	Wastewater Treatment Plant
WQBEL	Water Quality Based Effluent Limitation	WWWIFA	Water & Wastewater Infrastructure Financing Agency

GENERAL PROJECT NOTES

1. THE CONTRACTOR AGREES THAT, IN ACCORDANCE WITH GENERALLY ACCEPTED CONSTRUCTION PRACTICES, THE CONTRACTOR WILL BE REQUIRED TO ASSUME SOLE AND COMPLETE RESPONSIBILITY FOR JOB SITE CONDITIONS DURING THE COURSE OF CONSTRUCTION OF THE PROJECT, INCLUDING SAFETY OF ALL PERSONS AND PROPERTY. THIS REQUIREMENT SHALL BE MADE TO APPLY CONTINUOUSLY AND NOT BE LIMITED TO NORMAL WORKING HOURS.
2. THE CONTRACTOR SHALL POST EMERGENCY TELEPHONE NUMBERS FOR POLICE, FIRE, AMBULANCE, AND THOSE AGENCIES RESPONSIBLE FOR MAINTENANCE OF UTILITIES IN THE VICINITY OF JOBSITE.
3. THE GENERAL CONTRACTOR IS RESPONSIBLE FOR COORDINATING ALL OF THE WORK PERFORMED BY HIS SUBCONTRACTORS, WITHOUT EXCEPTION.
4. THE CONTRACTOR SHALL IDENTIFY A RESPONSIBLE CONTACT PERSON, WHO IS AN EMPLOYEE OF THE CONTRACTOR, AND A 24-HOUR TELEPHONE NUMBER TO CALL TO RESOLVE PROBLEMS WITH NOISE, DUST OR OTHER CONSTRUCTION-RELATED ISSUES.
5. THE CONTRACTOR SHALL BE REQUIRED TO KEEP ALL CONSTRUCTION ACTIVITIES WITHIN THE RIGHTS-OF-WAY AND EASEMENTS OBTAINED FOR THIS PROJECT UNLESS OTHERWISE SHOWN. THIS SHALL INCLUDE, BUT NOT BE LIMITED TO, VEHICLES AND EQUIPMENT, LIMITS OF TRENCH EXCAVATIONS, AND STOCKPILED NEW MATERIAL.
6. THE CONTRACTOR SHALL PROVIDE PROTECTION DEVICES INCLUDING BARRICADES, FENCING, WARNING SIGNS, LIGHTS, FLAGGERS OR OTHER ITEMS NECESSARY TO ENSURE PUBLIC SAFETY WITHIN THE PROJECT SITE. THIS REQUIREMENT SHALL APPLY CONTINUOUSLY AND NOT BE LIMITED TO NORMAL WORKING HOURS.
7. CONTRACTOR SHALL EXERCISE DUE CAUTION DURING CONSTRUCTION TO PROTECT ANY EXISTING LANDSCAPING, FIXTURES, EQUIPMENT, CONCRETE SIDEWALK, CONCRETE DRIVEWAY, CONCRETE CURB & GUTTER, AND AC PAVING TO REMAIN. ANY DAMAGE RESULTING FROM CONTRACTOR OPERATIONS SHALL BE REPAIRED AS DIRECTED BY THE DISTRICT'S REPRESENTATIVE, AT NO ADDITIONAL COST TO THE DISTRICT.
8. CONTRACTOR SHALL CONFORM TO THE TOWN OF TIBURON MONUMENT PRESERVATION POLICY AND SHALL PRESERVE ALL SURVEY MARKERS AND MONUMENTATION. THE CONTRACTOR SHALL NOTIFY THE ENGINEER OF ANY EXISTING FEDERAL, STATE, COUNTY, AND PRIVATE LAND SURVEY MARKER REQUIRING RESETTING PRIOR TO ANY DISTURBANCE.
9. CONTRACTOR SHALL RESTORE ALL EXISTING PRIVATE AND PUBLIC IMPROVEMENTS TO THEIR EXISTING CONDITION OR BETTER. THIS INCLUDES, BUT IS NOT LIMITED TO ALL LANDSCAPING, IRRIGATION, DRIVEWAYS, AC PAVING, CONCRETE WORK AND UTILITIES UNLESS NOTED OR DIRECTED OTHERWISE BY THE DISTRICT'S REPRESENTATIVE.
10. WHILE WORKING ON THE PROJECT, THE CONTRACTOR AND ALL SUBCONTRACTORS SHALL COMPLY WITH THE DISTRICT'S CONFINED SPACE ENTRY PROCEDURES FOR ALL PERMIT SPACE ENTRIES. THE FOLLOWING SPACES ARE HEREBY DESIGNATED PERMIT SPACES: MANHOLES.

LAYOUT NOTES

11. SHOULD IT APPEAR THAT THE WORK TO BE DONE OR ANY MATTER RELATIVE THERETO, IS INSUFFICIENTLY OR INCORRECTLY DETAILED OR EXPLAINED ON THESE PLANS, CONTRACTOR SHALL CONTACT THE DISTRICT'S REPRESENTATIVE FOR SUCH FURTHER EXPLANATIONS AS MAY BE NECESSARY.
12. THE CONTRACTOR SHALL NOTIFY THE DISTRICT'S REPRESENTATIVE IMMEDIATELY, UPON DISCOVERY OF ANY POTENTIAL FIELD CONFLICTS.
13. CONTOURS AND CONTOUR ELEVATIONS AS SHOWN ARE APPROXIMATE. CONTRACTOR SHALL VERIFY AS NEEDED.

APPROVALS & COORDINATION NOTES

14. A MINIMUM OF 2 WORKING DAYS, BUT NOT MORE THAN 14 CALENDAR DAYS, PRIOR TO COMMENCING ANY EXCAVATION WORK, THE CONTRACTOR SHALL CALL "UNDERGROUND SERVICE ALERT" AT 1-800-227-2600 FOR LOCATING AND MARKING UTILITIES IN THE AREAS OF THE WORK.
15. IT IS THE RESPONSIBILITY OF THE CONTRACTOR TO OBTAIN ALL PERMITS NECESSARY TO PERFORM THE WORK SHOWN IN THESE PLANS FROM THE APPROPRIATE AGENCIES, PRIOR TO COMMENCING WORK.
16. THE CONTRACTOR SHALL COMPLY WITH ALL LOCAL SOUND CONTROL AND NOISE LEVEL RULES, REGULATION AND ORDINANCES WHICH APPLY TO ANY WORK PERFORMED UNDER THE CONTRACT. EACH INTERNAL COMBUSTION ENGINE USED ON THE PROJECT SHALL BE EQUIPPED WITH A MUFFLER RECOMMENDED BY THE MANUFACTURER. NO INTERNAL COMBUSTION ENGINE SHALL BE OPERATED ON THE PROJECT WITHOUT SAID MUFFLER. NOISE LEVELS SHALL BE KEPT TO THE SATISFACTION OF THE CITY ENGINEER. HOURS OF WORK SHALL BE LIMITED TO 8:00 AM TO 6:00 PM MONDAY THROUGH FRIDAY WITHOUT PRIOR WRITTEN APPROVAL.
17. COORDINATE ALL WORK INVOLVING UTILITIES WITH THE APPROPRIATE UTILITY COMPANY.
18. LOCATIONS OF UTILITIES SHOWN ARE FROM RECORDS OF THE VARIOUS UTILITY COMPANIES. THE DISTRICT AND ITS ENGINEER MAKE NO GUARANTEE THAT THE LOCATIONS OF UTILITIES ENCOUNTERED WILL NOT BE DIFFERENT THAN THOSE SHOWN. THE CONTRACTOR SHALL BE RESPONSIBLE FOR VERIFYING AND MAKING HIS(HER) OWN DETERMINATION OF LOCATIONS OF EXISTING UTILITIES BY POTHOLING (HAND EXCAVATING) POTENTIAL CONFLICTS IN ADVANCE OF CONSTRUCTING THE CONTRACT PIPELINES.
19. LOCATIONS OF ALL UTILITY LATERALS & SERVICES ARE NOT ALL SHOWN. THE CONTRACTOR IS RESPONSIBLE FOR DETERMINING LOCATIONS OF SERVICE LATERALS AND FOR PROTECTING AND/OR COORDINATING THE RELOCATION OF EACH BY THE UTILITY COMPANY AS NECESSARY. POTHOLING OF UTILITY LATERALS AND SERVICES SHALL BE INCLUDED IN BID PRICE FOR SEWER LINE.
20. THE OVERHEAD ELECTRIC AND TELEPHONE DISTRIBUTION SYSTEMS AND INDIVIDUAL SERVICE LINES EXIST IN THE VICINITY OF THE WORK AREA AND ARE NOT ALL SHOWN ON THE DRAWINGS. CONTRACTOR SHALL EXERCISE CAUTION WHILE WORKING NEAR OR UNDER ALL ELECTRIC LINES.
21. THE CONTRACTOR SHALL PHYSICALLY LOCATE AND UNCOVER (POTHOLE) ALL UTILITIES IN THE ALIGNMENT OF THE NEW CONSTRUCTION OR AS REQUIRED ON THE PLANS AND SHALL BE RESPONSIBLE FOR DAMAGE THERETO.
22. THE CONTRACTOR SHALL PROVIDE WRITTEN NOTIFICATION TO ALL AFFECTED RESIDENTS AT LEAST ONE WEEK PRIOR TO COMMENCING WORK.

TEMPORARY PUMPING NOTES

23. THE CONTRACTOR SHALL BE RESPONSIBLE FOR PROVIDING CONTINUOUS PUMPING OF ALL SEWAGE AROUND WORK AREA. THE CONTRACTOR SHALL SUBMIT A BYPASS PUMPING PLAN. EXCAVATION OR PIPEBURSTING SHALL NOT COMMENCE UNTIL BYPASS PUMPING PLAN HAS BEEN FAVORABLY REVIEWED BY THE DISTRICT.
24. PROVIDE ADEQUATE TEMPORARY PUMPING CAPACITY WHILE SEWER IS BEING REHABILITATED.
25. PROTECT DOWNSTREAM SEWER FROM ENTRANCE OF ROCKS AND DEBRIS.
26. DURING NON WORKING HOURS TEMPORARILY RECONNECT EXISTING SEWER TO NEWLY PLACED SEWER.
27. CONTRACTOR SHALL BE RESPONSIBLE FOR DAMAGE TO SEWERS, PRIVATE LATERALS, SPILLS, FINES, ETC THAT MAY RESULT FROM IMPROPER OPERATION OF TEMPORARY PUMPS AND/OR FAILURE TO RESPOND TO ALARMS OR OVERFLOWS.
28. IF TEMPORARY PUMPS ARE OUT OF SERVICE FOR ANY REASON THE CONTRACTOR SHALL PROVIDE TANK TRUCKS TO PUMP OUT SEWAGE AND TRANSPORT TO THE SANITARY DISTRICT NO. 5 TREATMENT PLANT AS DESIGNATED BY THE DISTRICT.

GENERAL TRAFFIC CONTROL REQUIREMENTS

29. THE CONTRACTOR SHALL PREPARE AND SUBMIT CONSTRUCTION ZONE TRAFFIC CONTROL PLANS DRAWN TO 1"=20' SCALE PREPARED USING CALTRANS DETAILS AND PRACTICES FOR WORK ZONE TRAFFIC SAFETY AND TRAFFIC CONTROL. THE PLAN SHALL SHOW ALL EXISTING AND ALL PROPOSED TEMPORARY TRAFFIC CONTROL DEVICES, SIGNING AND STRIPING. TEMPORARY STRAIGHT THROUGH TRAFFIC LANES SHALL BE A MINIMUM OF 11 FEET WIDE. CURVED LANES AND TURNING LANES SHALL BE WIDE ENOUGH TO SAFELY ACCOMMODATE TRUCK AND BUS TRAFFIC. TEMPORARY BUS STOPS SHALL BE ESTABLISHED WHERE NECESSARY. THESE PLANS SHALL BE PROPERLY DIMENSIONED, MARKED AND SIGNED USING APPROPRIATE MARKERS, CONES, K-RAILS, FLAGGERS, FLASHERS ARROW BOARDS AND OTHER DEVICES. THESE PLANS SHALL PROVIDE FOR THE SAFE PASSAGE OF BUS, AUTO, BICYCLE AND PEDESTRIAN TRAFFIC MODES THROUGH THE WORK AREA. THESE PLANS SHALL BE SUBMITTED AND APPROVED BY THE CITY OF TIBURON, THE CITY OF BELVEDERE, AND THE STATE OF CALIFORNIA (CALTRANS) AND THE DISTRICT PRIOR TO WORK ON PUBLIC STREETS.
30. ALL TRAFFIC CONTROL MEASURES AND TEMPORARY SIGNS, LIGHTS AND DEVICES SHALL BE IN ACCORDANCE WITH THE CALIFORNIA STATE DIVISION OF HIGHWAYS "MANUAL OF TRAFFIC CONTROL FOR CONSTRUCTION AND MAINTENANCE WORK ZONES", CURRENT EDITION.
31. THE CONTRACTOR SHALL NOTIFY RESIDENTS AND BUSINESSES REGARDING PLANNED DETOURS AND PARKING RESTRICTIONS IN WRITING AT LEAST ONE (1) WEEK BEFORE THE START OF CONSTRUCTION AND 48 HOURS PRIOR TO THE DETOUR OR PARKING RESTRICTION.
32. THE CONTRACTOR SHALL TAKE ALL NECESSARY PRECAUTIONS TO ALLOW EMERGENCY VEHICLES TO PASS THROUGH THE CONSTRUCTION ZONES WITHOUT ANY DELAYS.
33. DURING NON-WORKING HOURS AND WHERE TRAFFIC MUST BE DETOURED OVER ALREADY LAID PIPE, ALL TRENCHES SHALL EITHER BE BACKFILLED AND PAVED WITH HOT MIX AC PAVING OR COVERED WITH STEEL PLATES WITH A NON-SKID SURFACE, AND CUT BACK AT THE EDGES AND ALL STREETS AND DRIVEWAYS SHALL BE OPEN TO NORMAL TRAFFIC AND PARKING ON BOTH SIDES OF THE STREET. USE OF "CUT BACK" ASPHALT FOR TEMPORARY TRENCH PAVING IN THE PUBLIC RIGHT OF WAY IS NOT PERMITTED UNLESS APPROVED IN WRITING BY THE CITIES OF BELVEDERE AND TIBURON.
34. ALLOW ACCESS TO DRIVEWAYS AT ALL TIMES UNLESS OTHERWISE SPECIFIED.
35. THE SPEED LIMIT THRU ANY DELINEATED AREAS SHALL BE POSTED AS 25 MPH.
36. THE COST OF ALL TRAFFIC CONTROL, INCLUDING ALL BARRICADES, DELINEATORS AND FLAGGERS, SHALL BE INCLUDED IN THE BID PRICE FOR TRAFFIC CONTROL.
37. THE CONTRACTOR SHALL CONTACT CITY OF TIBURON AND THE CITY OF BELVEDERE. TO CO-ORDINATE ANY AND ALL WORK NEAR INTERSECTIONS. THE CONTRACTOR SHALL BE RESPONSIBLE FOR MAINTAINING TRAFFIC CONTROL AT SIGNALIZED INTERSECTIONS WHEN WORKING AT OR WITHIN 100 FEET OF ANY SIGNALIZED INTERSECTION.
38. SERVICE LATERALS ARE NOT SHOWN ON THE PLANS. THE CONTRACTOR SHALL ASSUME THERE IS AT LEAST ONE SERVICE LATERAL PER BUILDING AND SHALL LOCATE ALL SERVICE LATERALS BY INTERNAL TELEVISION OF SEWER MAIN PRIOR TO PIPEBURSTING. AFTER INSTALLATION OF THE PIPE. THE CONTRACTOR SHALL REINSTATE EACH LATERAL WITHOUT EXCEPTION.

LATERAL NOTE

ABBREVIATIONS INCLUDE BUT ARE NOT LIMITED TO:

- | | |
|-------------------------------|--------------------------------|
| ABFM - ABANDONED FORCE MAIN | MB - MACHINE BOLT |
| ACP - ASBESTOS CEMENT PIPE | MIN - MINIMUM |
| BM - BENCH MARK | MON - MONUMENT |
| BOT - BOTTOM | O.D. - OUTSIDE DIAMETER |
| CC - ON CENTER | OH - OVERHEAD |
| CLR - CLEAR | OPNG - OPENING |
| CONC - CONCRETE | PL - PLATE |
| CONN - CONNECT, CONNECTION | PP - POWER POLE |
| DI - DUCTILE IRON | PS - PUMP STATION |
| DISCH - DISCHARGE | PUE - PUBLIC UTILITY EASEMENT |
| DWY - DRIVEWAY | PVC - POLY VINYL CHLORIDE |
| E - ELECTRICAL | RCP - REINFORCED CONCRETE PIPE |
| EL - ELEVATION | SCH - SCHEDULE |
| ELEC - ELECTRIC | SHT - SHEET |
| (E) - EXISTING | SPECS - SPECIFICATIONS |
| EWEF - EACH WAY EACH FACE | SS - STAINLESS STEEL |
| EXPJT - EXPANSION JOINT | STA - STATION |
| FCA - FLANGE COUPLING ADAPTER | STD - STANDARD |
| FL - FLOWLINE | STL - STEEL |
| G.GAS - GAS | TEL - TELEPHONE |
| GALV - GALVANIZED | TYP - TYPICAL |
| I.D. - INSIDE DIAMETER | VCP - VITRIFIED CLAY PIPE |
| INV - INVERT | W - WATER |
| IPS - IRON PIPE SIZE | W/ - WITH |
| JP - JOINT POLE | WM - WATER METER |
| LAT - LATERAL | |
| LB - POUND | |
| MAX - MAXIMUM | |

LEGEND

- | | | | |
|--------|---------------------------|--|----------------------------------|
| — W — | WATER LINE | | JOINT POLE & JOINT POLE WITH GUY |
| — FW — | FIRE WATER LINE | | FIRE HYDRANT |
| — RW — | RECLAIMED WATER LINE | | CATCH BASIN |
| — G — | GAS LINE | | GAS METER & VALVE |
| — G — | HIGH PRESSURE GAS LINE | | WATER METER & VALVE |
| — JT — | JOINT TRENCH LINE | | SURVEY MONUMENT |
| — E — | ELECTRIC LINE | | SURVEY BENCHMARK |
| — OH — | OVERHEAD UTILITY LINE | | STREET LIGHT |
| — T — | COMMUNICATIONS LINE | | NEW SEWER CLEANOUT |
| — FO — | FIBER OPTIC LINE | | EXISTING SEWER CLEANOUT |
| — TS — | TRAFFIC SIGNAL CONDUIT | | NEW SEWER MANHOLE |
| — TV — | COMMUNICATIONS LINE | | EXISTING SEWER MANHOLE |
| — SS — | EXISTING SEWER LINE | | NEW ROD HOLE |
| — FM — | EXISTING SEWER FORCE MAIN | | EXISTING ROD HOLE |
| — | NEW SEWER MAIN | | STORM DRAIN MANHOLE |
| — | STORM DRAIN LINE | | TELE/COMM MANHOLE & VAULT |
| — | ABANDONED LINE | | ELECTRIC MANHOLE & VAULT |
| — | RETAINING WALL | | TRAFFIC SIGNAL |

NOT APPROVED FOR CONSTRUCTION

**SANITARY DISTRICT No. 5
2024 SEWER REHABILITATION PROJECT**

NOTES, ABBREVIATIONS AND LEGEND

NO.	DATE	DESCRIPTION	INIT.

PREPARED BY:

NUIE
Civil and Sanitary Consultants
907 MISSION AVE. SAN RAFAEL, CA 94901
T: 415.453.4460 WWW.NUIE.BIZ

PREPARED FOR:
SANITARY DISTRICT No. 5
2007 PARADISE DRIVE
TIBURON, CA 94920
PHONE: (415) 455-1501
FAX: (415) 455-0221

MARBIN COUNTY CALIFORNIA

- EXISTING CONCRETE SHALL BE REMOVED AT EXPANSION OR WEAKENED PLANE JOINTS OR AT SAWCUTS AS FIELD MARKED BY AGENCY ENGINEER. SAWCUTS MUST GO ENTIRELY THROUGH CONCRETE.
- FOR NEW DEVELOPMENT, NO UTILITY BOXES OR POLES WILL BE PERMITTED IN THE SIDEWALK AREA WITHOUT THE PRIOR WRITTEN APPROVAL OF THE AGENCY ENGINEER.
- WHERE UNDERCUT SUBGRADE OR UNSUITABLE SUBGRADE MATERIAL IS ENCOUNTERED, THE AGENCY ENGINEER MAY REQUIRE REMEDIAL WORK TO BE DONE, INCLUDING OVER EXCAVATION AND BACKFILLING WITH CRUSHED ROCK AND, WHEN DIRECTED BY THE ENGINEER, PLACING GEOTEXTILE FABRIC BENEATH THE NEW CONCRETE SECTION.
- SUBGRADE SHALL BE COMPACTED TO AT LEAST 95% RELATIVE COMPACTION IN THE TOP SIX INCHES.
- NEW WORK SHALL MATCH EXISTING AS CLOSELY AS POSSIBLE IN FINISH, SCORING AND COLOR. FOR NEW INSTALLATIONS PLACED ADJACENT TO EXISTING, 2LB. DAVIS BLACK #8084 (OR EQUIVALENT) PER CU. YD. CONCRETE SHALL BE ADDED TO MIX.
- EXCEPT WHERE SPECIFIED OTHERWISE HEREIN, NO ADMIXTURES SHALL BE USED WITHOUT THE PERMISSION OF THE AGENCY ENGINEER.
- FORMS SHALL MEET GRADE AND FORM FACES SHALL NOT VARY FROM THE DIMENSIONS SHOWN BY MORE THAN 1/2 INCH.
- NO CONCRETE SHALL BE PLACED UNTIL THE AGENCY ENGINEER HAS INSPECTED AND APPROVED FORMS AND SUBGRADE/BASE.
- SUBGRADE/BASE SHALL BE THOROUGHLY WETTED IMMEDIATELY PRIOR TO PLACING CONCRETE.
- CONCRETE SHALL BE A MINIMUM CLASS B (5 SACK MIX) WITH 1 INCH MAXIMUM AGGREGATE FROM AN APPROVED MIXING PLANT. NO BAGGED MIX IS PERMITTED.
- CONCRETE SHALL HAVE A SLUMP OF NOT MORE THAN FOUR INCHES.
- FOR SIDEWALKS AND DRIVEWAY APPROACHES, 1/4 INCH DEEP SCORE LINES SHALL BE PLACED AT FOUR FEET ON CENTER OR AS DIRECTED BY THE AGENCY ENGINEER.
- WEAKENED PLANE JOINTS AT LEAST 3/4" DEEP SHALL BE PLACED AT A MINIMUM 16 FEET ON CENTER EXCEPT FOR SIDEWALKS AND DRIVEWAY APPROACHES WHICH SHALL BE A MINIMUM 5 FEET ON CENTER.
- 3/8 INCH THICK EXPANSION JOINTS SHALL BE PLACED ON BOTH SIDES OF DRIVEWAY APPROACHES, AT CURB AND SIDEWALK RETURN POINTS, DRAINAGE STRUCTURES AND OTHER LOCATIONS AS SHOWN ON THE PLANS.
- ALL EXPOSED EDGES SHALL BE ROUNDED WITH 1/2 INCH RADIUS TOOL.
- ALL FLAT SURFACES SHALL BE LIGHT BROOM FINISHED UNLESS OTHERWISE SPECIFIED BY AGENCY ENGINEER.
- CURBS, SIDEWALKS AND DRIVEWAY APPROACHES SHALL HAVE FORMS REMOVED AND BE BACKFILLED WITHIN SEVEN DAYS AFTER POURING.
- THE DESIGNATED DIMENSIONS AND SLOPES MAYBE MODIFIED TO ACCOMMODATE EXISTING ADJACENT FACILITIES SUBJECT TO THE APPROVAL OF THE AGENCY ENGINEER.

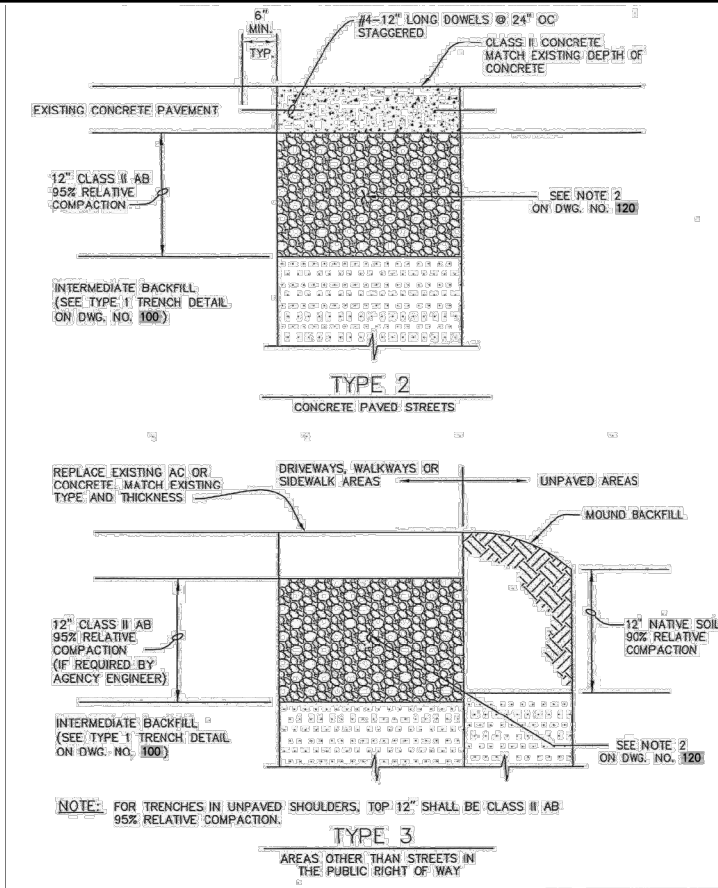
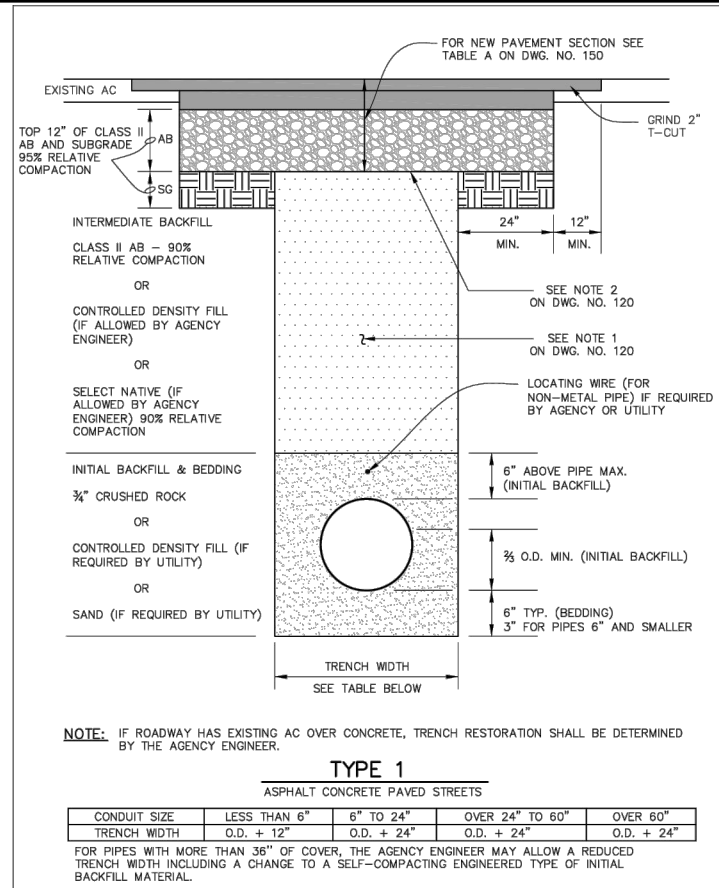
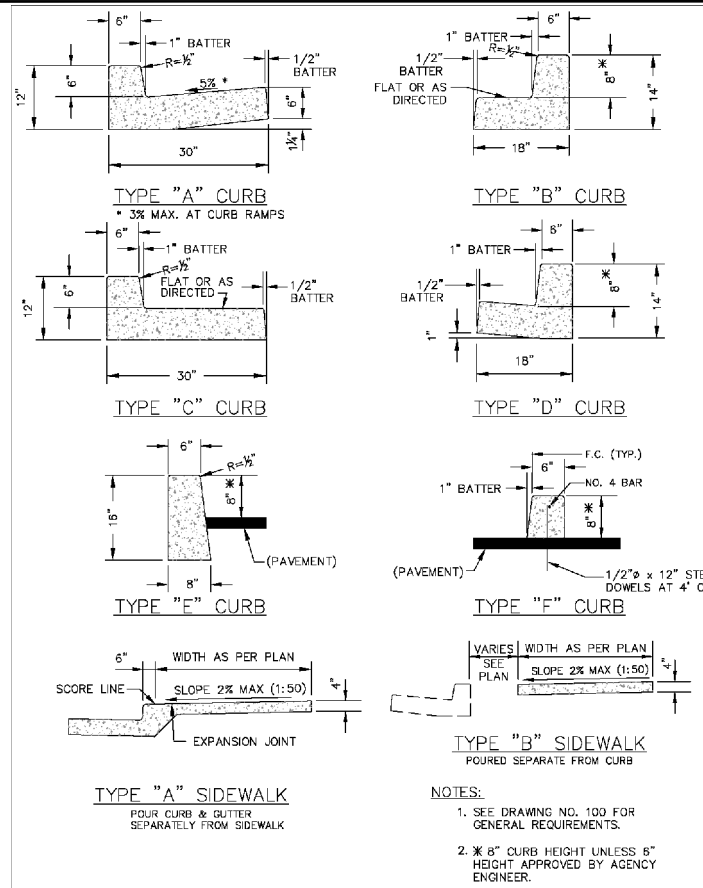

TOWN OF TIBURON UNIFORM STANDARDS ALL CITIES AND COUNTY OF MARIN	REQUIREMENTS FOR CONCRETE CURB, GUTTER, SIDEWALK, DRIVEWAY AND OTHER "FLATWORK"	REV.	DATE	BY	MARCH 2018 DWG. NO. 100
--	---	------	------	----	-------------------------------

TOWN OF TIBURON UNIFORM STANDARDS ALL CITIES AND COUNTY OF MARIN	CURB, GUTTER AND SIDEWALK DETAILS	REV.	DATE	BY	MARCH 2018 DWG. NO. 105
--	---	------	------	----	-------------------------------

TOWN OF TIBURON UNIFORM STANDARDS	TRENCH DETAILS SHEET 1 OF 3	REV.	DATE	BY	MAY 2017 DWG. NO. 100
--------------------------------------	--------------------------------	------	------	----	-----------------------------

TOWN OF TIBURON UNIFORM STANDARDS	STANDARD TRENCH BACKFILL & RESURFACING SHEET 2 OF 3	REV.	DATE	BY	MAY 2017 DWG. NO. 110
--------------------------------------	--	------	------	----	-----------------------------

- MATERIAL AND COMPACTION REQUIREMENT FOR TRENCH BACKFILL.**
- INTERMEDIATE BACKFILL SHALL BE CLASS II AGGREGATE BASE. SUITABLE NATIVE OR IMPORTED GRANULAR MATERIAL MAY BE USED IF ALLOWED BY AGENCY ENGINEER. RELATIVE COMPACTION SHALL BE AT LEAST 90%.
 - CLASS II AGGREGATE BASE SHALL CONFORM TO THE STATE STANDARD SPECIFICATIONS. MINIMUM RELATIVE COMPACTION SHALL BE 95%. IF PAVEMENT HAVING A STRUCTURAL SECTION GREATER THAN 15" IS CUT, ADDITIONAL BASE MATERIAL MAY BE REQUIRED BY THE AGENCY ENGINEER. BASE SHALL BE PLACED AND COMPACTED PRIOR TO PLACING OF TEMPORARY PAVING.
 - TESTING OF MATERIALS AND PERFORMANCE SHALL BE IN CONFORMANCE WITH THE METHODS STATED IN THE LATEST EDITION OF THE STATE OF CALIFORNIA, DEPARTMENT OF TRANSPORTATION, STANDARD SPECIFICATIONS, EXCEPT THAT RELATIVE COMPACTION MAY BE TESTED BY AASHTO METHOD T180, ASTM D-1557, OR TEST METHOD CALIF. 231 (NUCLEAR DENSITOMETER).
 - PLACE AC IN 3" MAX. LIFTS, EXCEPT FINAL LIFT SHALL BE 2 1/2" MAX. ADDITIONAL THICKNESS AND LIFTS OF ASPHALT CONCRETE MAY BE REQUIRED TO MATCH EXISTING STRUCTURAL SECTION ON MAJOR ROADS, OR PER LOCAL JURISDICTION REQUIREMENTS.
 - "JETTING" OF BACKFILL MATERIAL IS NOT PERMITTED.
 - THE USE OF PEA GRAVEL (OR SIMILAR ROUNDED AGGREGATE), IS NOT PERMITTED.
 - THE USE OF CONTROLLED DENSITY FILL (CDF) SHALL BE APPROVED BY THE AGENCY ENGINEER PRIOR TO PLACEMENT.
 - TRENCH EDGES SHALL BE TRIMMED TO A NEAT LINE AS REQUIRED BY THE AGENCY ENGINEER. TRIMMING SHALL BE BY SAWCUT OR ROTARY GRINDER.
 - THE SURFACE COURSE OF TRENCH RESTORATION SHALL EXTEND TO THE UP OF GUTTER IF THE EDGE OF TRENCH IS WITHIN 4' OF THE LIP OF GUTTER, AND TO THE EDGE OF PAVEMENT IF THE EDGE OF TRENCH IS WITHIN 4' OF AN UNPAVED SHOULDER.
 - CONTRACTOR MUST SHORE ALL TRENCHES IN CONFORMANCE WITH OSHA AND STATE SAFETY STANDARDS.

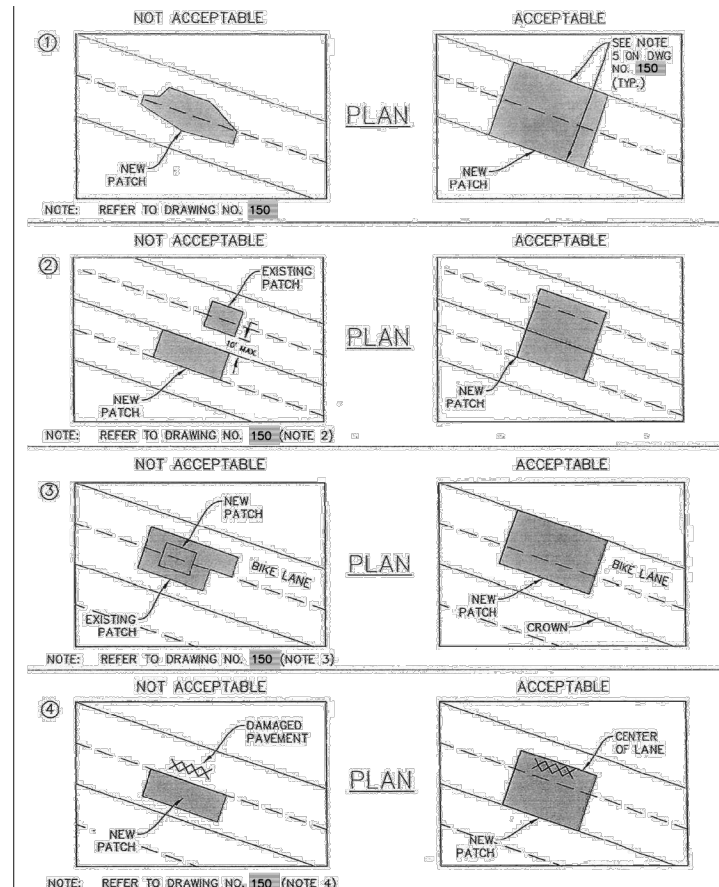
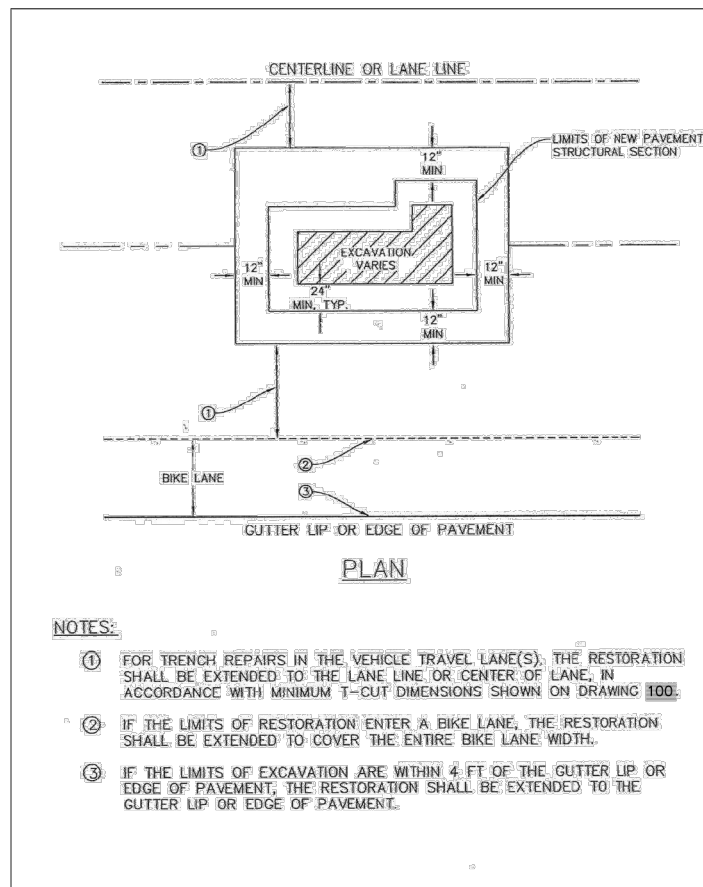

RESTORATION OF ASPHALT REQUIREMENTS.

NOTES:

- EXISTING PAVEMENTS SHALL BE REMOVED TO CLEAN, STRAIGHT LINES PARALLEL AND PERPENDICULAR TO THE FLOW OF TRAFFIC. DO NOT CONSTRUCT FINAL RESTORATION WITH ANGLED SIDES AND IRREGULAR SHAPES.
- IF A PROPOSED CUT IS WITHIN 10 FT OF AN EXISTING PATCH, EXTEND THE FINAL RESTORATION TO THE EXISTING PATCH (FOR BELL HOLE OR TRENCH NO GREATER THAN 10 FT LONGITUDINAL).
- IF A NEW PATCH IS DONE WITHIN AN EXISTING PATCH, THE BOUNDARIES OF THE FINAL RESTORATION FOR THE PATCHES SHALL COINCIDE.
- IF A SECTION OF PAVEMENT IS DAMAGED DURING CONSTRUCTION, THE FAILED AREA SHALL BE REMOVED TO SOUND PAVEMENT AND PATCHED. IF THE DAMAGED AREA IS WITHIN 10 FT OF THE NEW PATCH, THE FINAL RESTORATION OF THE PATCHES SHALL COINCIDE.
- LIMITS OF FINAL PAVEMENT RESTORATION TO STOP AT ONE OF THE FOLLOWING LOCATIONS: CENTER OF LANE, TRAVEL LANE LINE, BIKE LANE LINE, ISLAND CURB/GUTTER, EDGE OF ROADWAY PAVEMENT CURB/GUTTER.
- STEEL PLATES USED FOR BRIDGING SHALL EXTEND A MINIMUM OF 1 FT. BEYOND THE EDGE OF TRENCH. PLATES SHALL HAVE NONSKID ABRASIVE SURFACE PER CALTRANS SPECIFICATIONS 75-1.03F, AND COUNTER-SINKING MAY BE REQUIRED WHEN DEEMED NECESSARY BY AGENCY ENGINEER.
- CUTBACK SHALL NOT BE USED EXCEPT WHEN PRE-APPROVED BY THE AGENCY ENGINEER OR WHEN TRIMMING TRENCH PLATES.

Table A

Road Type	Traffic Index**	Min. (T) AC	Final Surface AC, Min.	Pavement Repair Structural Section	
				Assumes R-Value = 10*	Alternate Deep LIR A.C.
Local	5.0	4"	2.0"	4.0"	7.0"
Collector	6.5	5"	2.0"	5.0"	11.0"
Arterial**	8.0	6"	3.0"	6.0"	14.0"

Notes:
*Unless applicant provides actual R-Value test results and pavement section design.
**Or as approved by City/County Engineer based on actual traffic loading.

TOWN OF TIBURON UNIFORM STANDARDS	TRENCH NOTES SHEET 3 OF 3	REV.	DATE	BY	MAY 2017 DWG. NO. 120
--------------------------------------	------------------------------	------	------	----	-----------------------------

TOWN OF TIBURON UNIFORM STANDARDS	RESTORATION OF ASPHALT SHEET 1 OF 3	REV.	DATE	BY	MAY 2017 DWG. NO. 130
--------------------------------------	---	------	------	----	-----------------------------

TOWN OF TIBURON UNIFORM STANDARDS	RESTORATION OF ASPHALT SHEET 2 OF 3	REV.	DATE	BY	MAY 2017 DWG. NO. 140
--------------------------------------	---	------	------	----	-----------------------------

TOWN OF TIBURON UNIFORM STANDARDS	RESTORATION OF ASPHALT SHEET 3 OF 3	REV.	DATE	BY	MAY 2017 DWG. NO. 150
--------------------------------------	---	------	------	----	-----------------------------

PREPARED BY: SANITARY DISTRICT No. 5
2007 PARADISE DRIVE
TIBURON, CA 94920
PHONE: (415) 435-1501
FAX: (415) 435-0221

DESIGNED BY: BEO
DRAWN BY: BEO
CHECKED BY: MTW

DATE: October 14, 2024

DESCRIPTION: 2024 SEWER REHABILITATION PROJECT

UNIFORM STANDARDS ALL CITIES AND COUNTY OF MARIN

NOT APPROVED FOR CONSTRUCTION

UNIFORM STANDARDS ALL CITIES AND COUNTY OF MARIN

JOB NUMBER: 9173
DATE: October 14, 2024
PAGE: 3 of 18

MANHOLE BASE NOTES:

1. MANHOLE BASE SHALL BE CLASS A (6-SACK) CONCRETE AND SHALL BE POURED AGAINST UNDISTURBED SOIL.
2. PRECAST CONCRETE CONE, BARREL AND GRADE RINGS SHALL CONFORM TO A.S.T.M. SPEC C-478, EXCEPT THAT TYPE II MODIFIED PORTLAND CEMENT SHALL BE USED.
3. FRAME AND COVER MAY BE ADJUSTED TO GRADE LEVEL EITHER BEFORE OR AFTER PAVING, BUT FINAL GRADE SHALL CONFORM TO ADJACENT FINISH PAVEMENT GRADE WITHIN 1/8".
4. ECCENTRIC CONE SECTION SHALL BE POSITIONED ON THE DOWNSTREAM PORTION OF THE MANHOLE OR AS DIRECTED BY THE DISTRICT.
5. WHERE FRAME AND COVER IS SET AFTER PAVING, THE CONCRETE COLLAR SHALL BE BROUGHT TO FINISH GRADE AND THE EXPOSED CONCRETE SURFACE SHALL BE COLORED WITH LAMPBLACK.
6. RECESS IN MANHOLE BASE SHALL BE FORMED WITH AN APPROVED METAL FORMING RING TO RECEIVE PRECAST MANHOLE JOINT. PREFORMED PLASTIC SEAL GASKET SHALL BE INSTALLED BEFORE PLACING FIRST BARREL SECTION.
7. PRECAST MANHOLE BASES WILL NOT BE ALLOWED UNLESS SPECIFICALLY APPROVED BY DISTRICT. HOWEVER, THE DISTRICT RESERVES THE RIGHT TO REJECT ANY MANHOLE BASE, THAT IS NOT SUITABLE FOR THE FIELD CONDITIONS. IN ADDITION ALL MANHOLE BASES SHALL BE A THICKNESS OF 10" FROM THE INVERT TO THE BOTTOM OF THE BASE.
8. FOR ALL MANHOLES, THE VERTICAL SIDE OF THE ECCENTRIC CONE SHALL BE LOCATED AT THE DOWN STREAM PORTION OF THE MANHOLE.

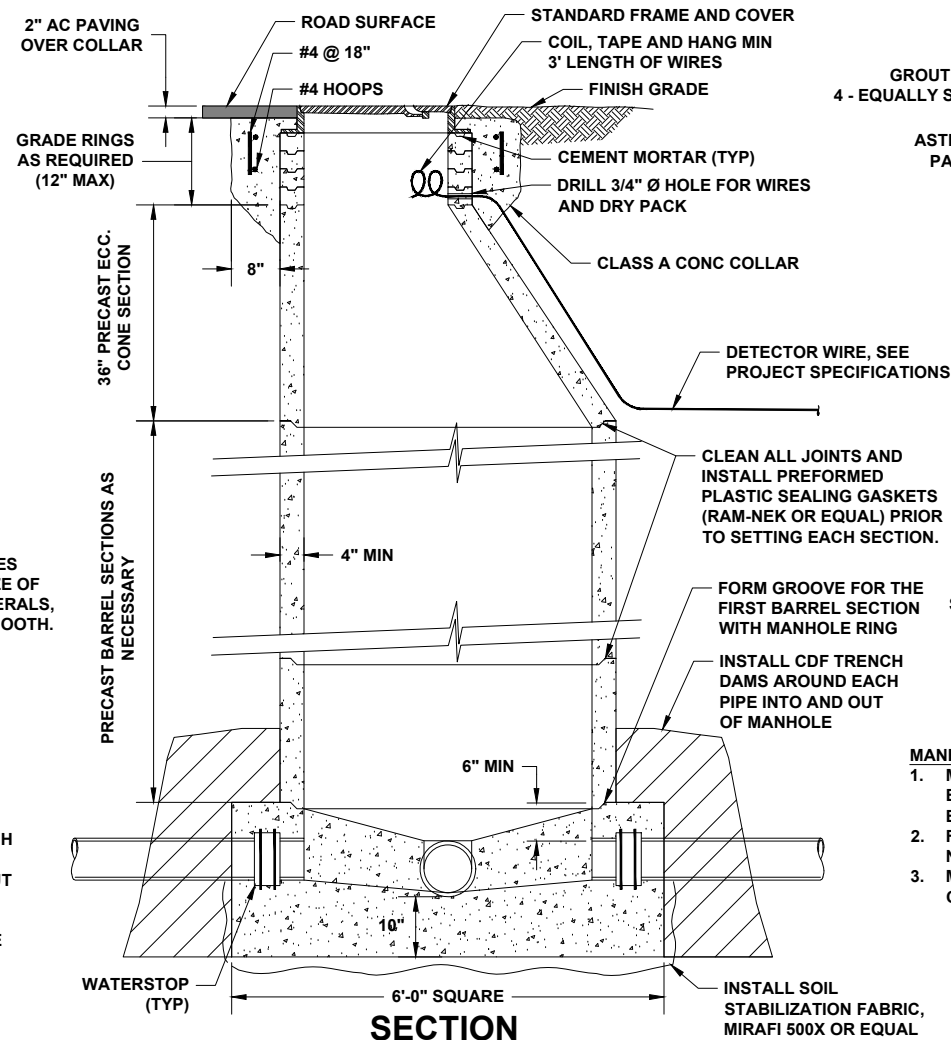

STANDARD MANHOLE DETAILS 1/4
N.T.S.

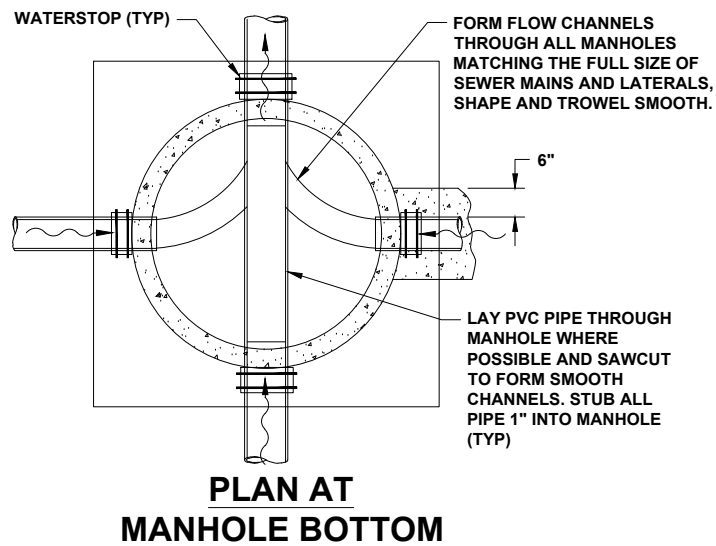

PLAN AT MANHOLE BOTTOM

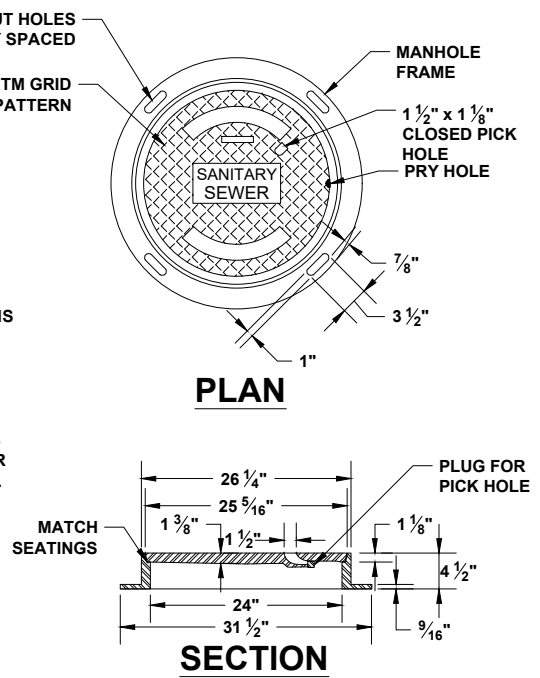

- MANHOLE FRAME AND COVER NOTES:**
1. MANHOLE FRAME AND COVER SHALL BE AS MANUFACTURED BY PHOENIX IRON WORKS, OAKLAND, No. P-1090 OR APPROVED EQUIVALENT.
 2. FOR MANHOLES LOCATED IN SIDEWALK AREAS, USE PHOENIX No. P-1067 FRAME AND COVER OR APPROVED EQUIVALENT.
 3. MINIMUM WEIGHT OF FRAME IS 138 LBS. MINIMUM WEIGHT OF COVER IS 130 LBS.

STANDARD MANHOLE FRAME & COVER

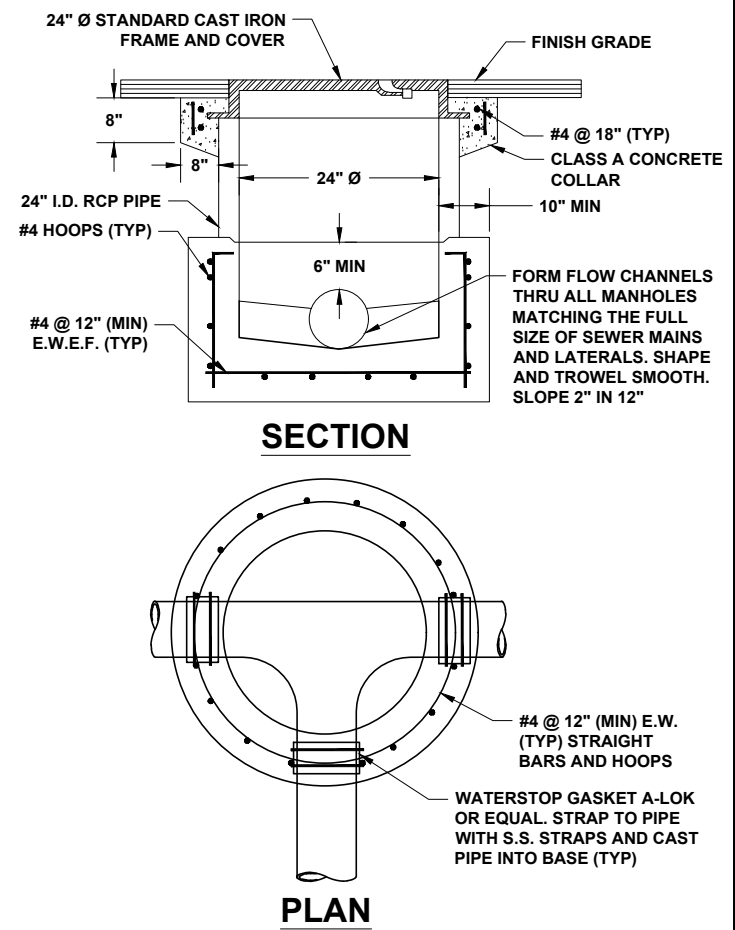

- 2' MANHOLE NOTES:**
1. MANHOLE BASE SHALL BE CLASS A (6-SACK) CONCRETE AND SHALL BE POURED AGAINST UNDISTURBED SOIL.
 2. PRECAST CONCRETE BARREL SHALL BE 24" I.D. REINFORCED CONCRETE PIPE. CENTRAL PRECAST OR EQUAL WITH GALVANIZED 12 GA WIRE FABRIC REINFORCING.

2' Ø SHALLOW MANHOLE 2/4
N.T.S.

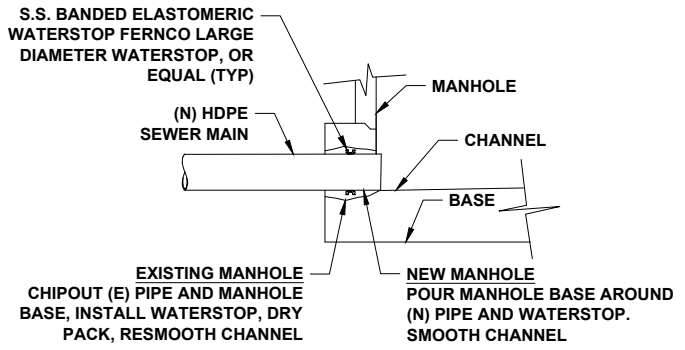

MANHOLE CONNECTION DETAIL 3/4
N.T.S.

INIT.	
DESCRIPTION	
NO.	
DATE	
BEO	
Drawn	
Checked	
MTW	
1"	
ALL DIMENSIONS UNLESS OTHERWISE NOTED ARE IN INCHES. THESE PLANS ARE NOT TO SCALE.	
PREPARED BY:	<p>NSI Civil and Sanitary Consultants 907 MISSION AVE. SAN RAFAEL, CA 94901 T: 415.453.4460 WWW.NSI.CA</p>
PREPARED FOR:	<p>SANITARY DISTRICT No. 5 2007 PARADISE DRIVE TEBRON, CA 94920 PHONE: (415) 455-1501 FAX: (415) 455-0221</p>
	<p>SANITARY DISTRICT No. 5 2024 SEWER REHABILITATION PROJECT</p>
	<p>MANHOLE DETAILS AND NOTES</p>
JOB NUMBER:	9173
DATE:	October 14, 2024
PAGE:	4 OF 18

NOT APPROVED FOR CONSTRUCTION

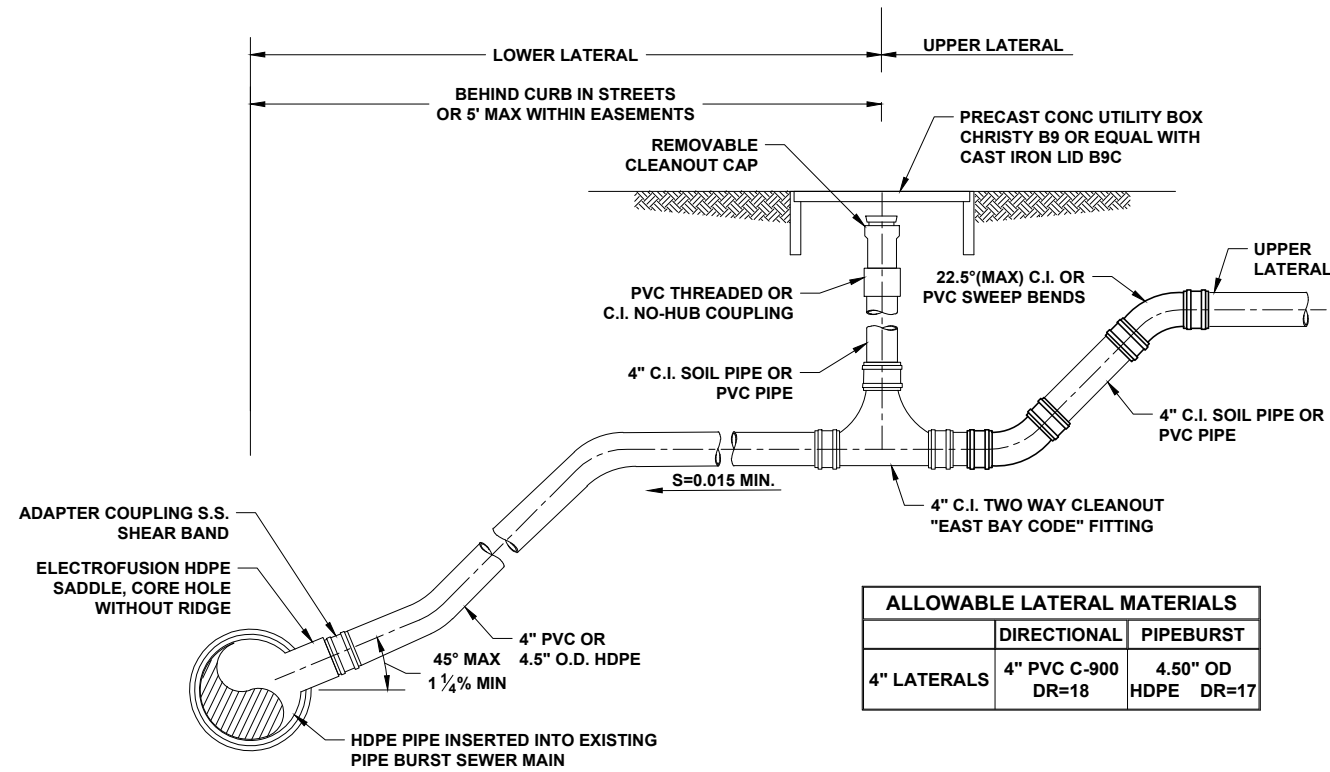

	DIRECTIONAL	PIPEBURST
4" LATERALS	4" PVC C-900 DR=18	4.50" OD HDPE DR=17

4" LATERAL REPLACEMENT 1/5
N.T.S.

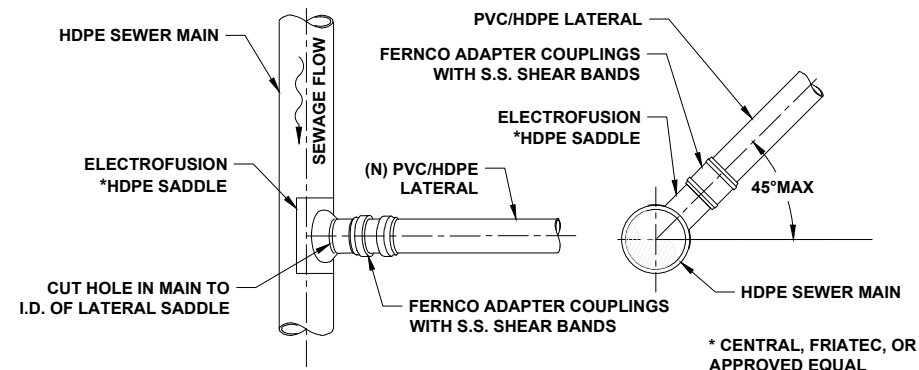

NOTE:
1. FOR LATERAL RECONNECTION ONLY, CONNECT EXISTING LATERAL TO ELECTROFUSION SADDLE WITH APPROX. 2 FT LONG PVC PIPE STUB AND STAINLESS STEEL SHEAR BANDED COUPLINGS.

LATERAL CONNECTION - HDPE SEWER MAIN 2/5
N.T.S.

LATERAL REHABILITATION REQUIREMENTS

- GENERAL - WHERE THE SEWER MAIN IS TO BE REHABILITATED THE CONTRACTOR SHALL REHABILITATE EACH EXISTING LATERAL. THE CONTRACTOR SHALL ASSUME THERE IS AT LEAST ONE SERVICE LATERAL PER BUILDING.
- LOCATION OF LATERALS - LATERAL LOCATIONS ARE NOT SHOWN ON THE PLANS. THE CONTRACTOR SHALL PHYSICALLY LOCATE ALL LATERALS BY PRE-CLEANING AND PRE-TELEVISIONING THE SEWER MAIN TO BE REHABILITATED PRIOR TO THE WORK.
- POTHOLES LATERALS - THE CONTRACTOR SHALL POTHOLE ALL LATERALS AT THE MAIN SEWER AND AT THE CONNECTION TO THE EXISTING LATERAL IN ADVANCE OF THE SEWER MAIN REHABILITATION. THE ALIGNMENT OF EACH LATERAL SHALL BE MARKED ON THE GROUND SURFACE WITH GREEN PAINT FROM THE STREET TO THE POINT OF CONNECTION WITH THE HOUSE LATERAL.
- PROTECTION OF POTHOLED LATERALS - LATERALS POTHOLED IN THE STREET SHALL BE COVERED WITH STEEL PLATES. LATERALS POTHOLED OUTSIDE THE TRAVELLED WAY SHALL BE COVERED WITH 3/4 INCH PLYWOOD. ALL SPOIL AND EXCAVATED MATERIALS SHALL BE STOCKPILED IN A LOCATION WHICH DOES NOT BLOCK PATHWAYS OR SIDEWALKS AND COVERED WITH VISQUENE.
- PIPE RELAXATION - THE INSTALLED PIPE SHALL BE ALLOWED THE MANUFACTURER'S RECOMMENDED AMOUNT OF TIME, BUT NOT LESS THAN FOUR (4) HOURS, FOR COOLING AND RELAXATION DUE TO TENSILE STRESSING PRIOR TO ANY RECONNECTION OF SERVICE LINES.
- RESTORATION OF SURFACE IMPROVEMENTS IN THE PUBLIC RIGHT OF WAY - RESTORATION OF SIDEWALKS, DRIVEWAY APPROACHES, CURBS AND GUTTERS AND AC PAVEMENT WITHIN THE PUBLIC RIGHT OF WAY SHALL BE PAID FOR ON THE BASIS OF THE BID ITEMS THEREFOR.
- RESTORATION OF IMPROVEMENTS ON PRIVATE PROPERTY - THE CONTRACTOR SHALL RESTORE ALL SURFACE IMPROVEMENTS ON PRIVATE PROPERTY INCLUDING ALL LANDSCAPING, FENCING, CONCRETE WALLS, SIDEWALKS, DRIVEWAYS, ETC. IN KIND. NOT ALL IMPROVEMENTS ARE SHOWN ON THE PLANS. THE CONTRACTOR SHALL ASSUME THAT ALL PRIVATE PROPERTY IS IMPROVED AND SHALL INCLUDE THE COST OF RESTORING ALL SURFACE IMPROVEMENTS ON PRIVATE PROPERTY IN THE BID FOR CONSTRUCTION OF SEWER LATERALS.
- PUBLIC RELATIONS - THIS PROJECT INVOLVES WORK ON OR NEAR PRIVATE PROPERTIES. THE CONTRACTOR SHALL SPECIFICALLY INSTRUCT ALL HIS WORKERS TO EXERCISE GOOD PUBLIC RELATIONS DURING THE WORK, INCLUDING BEING COURTEOUS, AVOIDING THE USE OF SWEAR WORDS, AND MINIMIZING DAMAGE TO PRIVATE PROPERTY. THE CONTRACTOR SHALL NOTIFY PROPERTY OWNERS PRIOR TO WORKING ON THEIR LATERAL.
- POST CONSTRUCTION LATERAL CCTV: - AFTER THE CONSTRUCTION OF THE LATERALS, CONTRACTOR SHALL POST TELEVISION NEW CONSTRUCTED LATERAL AND PROVIDE VIDEO FILES WITH WRITTEN LOG TO DISTRICT. IF NEW CONSTRUCTED LATERAL CANNOT BE POST TELEVISIONED, THEN LATERAL FUNCTION NEEDS TO BE VERIFIED BY DYE TESTING OF LATERAL WITH DISTRICT INSPECTOR PRESENT.

NOT APPROVED FOR CONSTRUCTION

**SANITARY DISTRICT No. 5
2024 SEWER REHABILITATION PROJECT**

LATERAL DETAILS AND NOTES

PREPARED BY: **NUJE** Civil and Sanitary Consultants
907 MISSION AVE. SAN RAFAEL, CA 94901
T: 415.453.4460 WWW.NUJE.BIZ

PREPARED FOR: **SANITARY DISTRICT No. 5**
2007 PARADISE DRIVE
TIBURON, CA 94920
PHONE: (415) 456-1501
FAX: (415) 456-0221

MARIN COUNTY CALIFORNIA

NO.	DESCRIPTION	DATE	INIT.
1			
2			
3			
4			
5			

DESIGNED BY: BEO
DRAWN BY: BEO
CHECKED BY: MTW
SCALE: 1" = 1'-0" (SEE NOTES FOR VERTICAL DIMENSIONS)
IF DIMENSIONS NOT TO SCALE, THESE PLANS ARE NOT TO SCALE.

P:\Projects\9173 SD5 2024 Sewer Rehab\CAD\9173 Titlesheet_details_notes.dwg

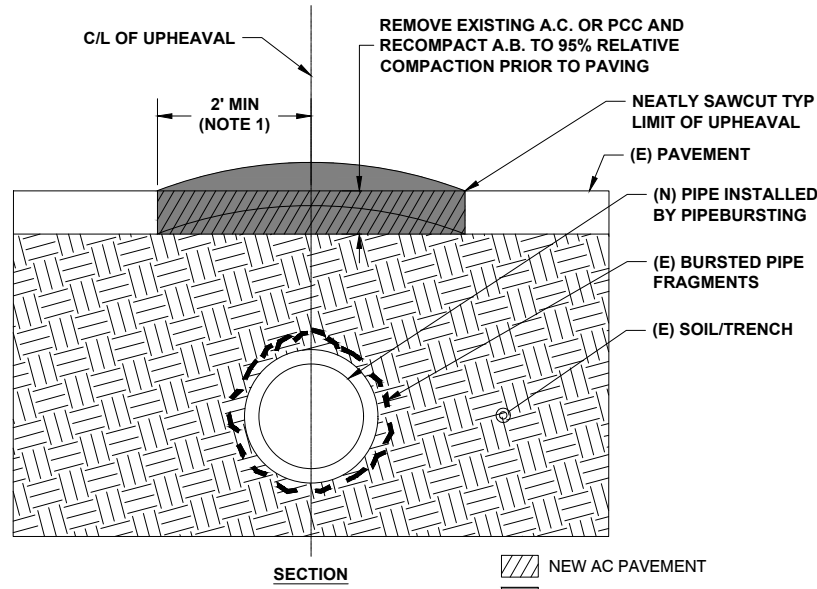

NOTE:
1. LIMITS OF PAVEMENT REPAIR TO BE VERIFIED BY DISTRICT OR ITS APPOINTED REPRESENTATIVE AFTER PIPEBURSTING.

SURFACE UPHEAVAL REPAIR 1/6
N.T.S.

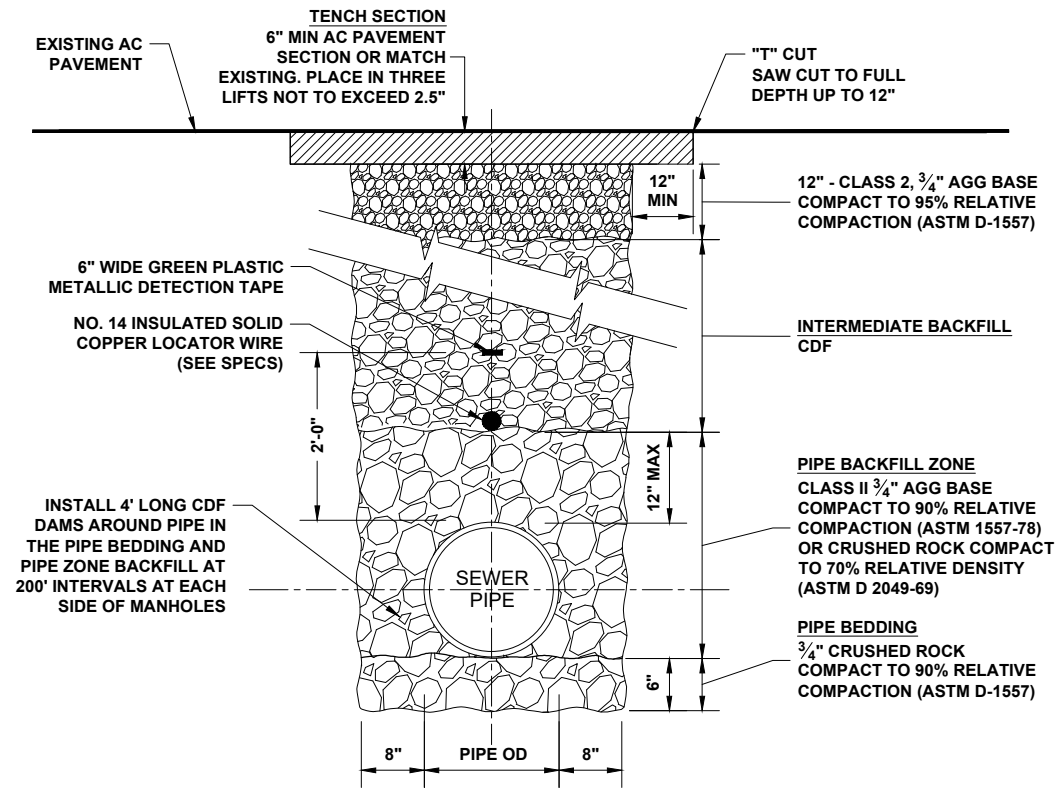

TYPICAL TRENCH SECTION 2/6
N.T.S.

SURFACE RESTORATION REQUIREMENTS:

- EXISTING AC THICKNESS OVER 8" SHALL BE MATCHED UNLESS OTHERWISE DIRECTED BY THE LOCAL AGENCY
- TRENCH SECTION DETAIL APPLIES TO BOTH SEWER MAINS AND SEWER LATERALS.
- "T" CUTS APPLY TO BOTH SIDES OF ALL TRENCHES.
- IN STREETS: CONFORM TO THE REQUIREMENTS OF TYPICAL TRENCH SECTION THIS SHEET. AC THICKNESS OVER TRENCH SHALL BE 6".
- IN EASEMENT AREAS:
 - BARE GROUND -- MOUND NATIVE SOIL
 - LANDSCAPED AREA -- PLACE TOP SOIL IN UPPER 12"
 - UNPAVED TRAVEL SURFACE -- PLACE 12" CLASS 2 AGG BASE

**NOT APPROVED
FOR CONSTRUCTION**

**SANITARY DISTRICT No. 5
2024 SEWER REHABILITATION PROJECT**
MISCELLANEOUS DETAILS

JOB NUMBER: **9173**
DATE: **October 14, 2024**
PAGE: **6 OF 18**

PREPARED FOR: **SANITARY DISTRICT No. 5**
2007 PARADISE DRIVE
TIBURON, CA 94920
PHONE: (415) 435-1501
FAX: (415) 435-0221
MARIN COUNTY CALIFORNIA

PREPARED BY: **NUJE**
Civil and Sanitary Consultants
907 MISSION AVE, SAN RAFAEL, CA 94901
T: 415.453.4460 WWW.NUJE.DIZ

DESIGNED BY: **BEO**
DRAWN BY: **BEO**
CHECKED BY: **MTW**
SCALE: **1" = 1'**
ALL DIMENSIONS UNLESS OTHERWISE SPECIFIED ARE IN INCHES. THESE PLANS ARE NOT TO SCALE.

NO.	DATE	DESCRIPTION	INIT.
1			
2			
3			
4			
5			

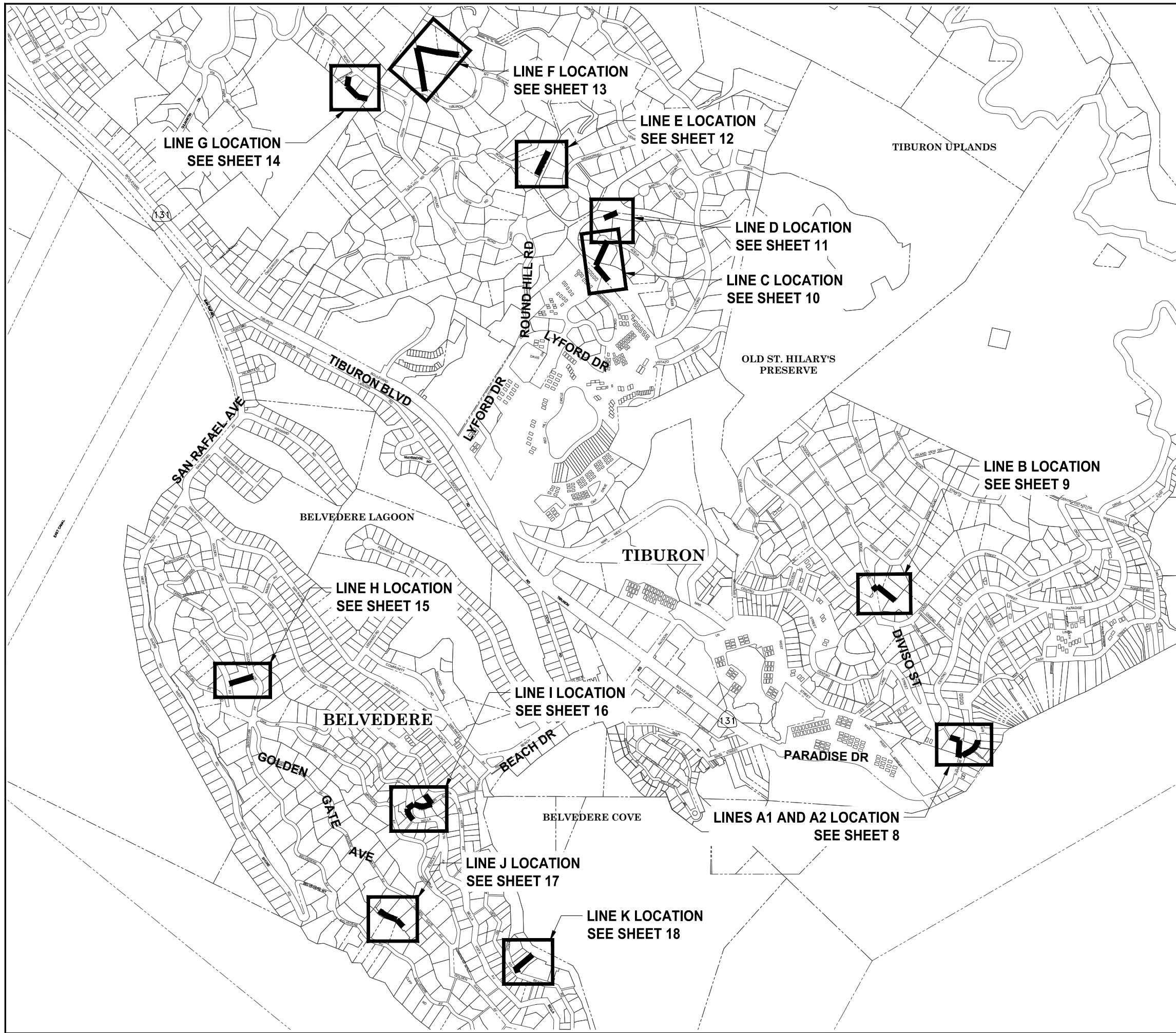

**NOT APPROVED
FOR CONSTRUCTION**

**SANITARY DISTRICT No. 5
2024 SEWER REHABILITATION PROJECT**

PROJECT KEY MAP

PREPARED FOR:

SANITARY DISTRICT No. 5
 2007 PARADISE DRIVE
 TIBURON, CA 94920
 PHONE: (415) 435-1501
 FAX: (415) 435-0221
 MARIN COUNTY CALIFORNIA

PREPARED BY:

NUTE
 Civil and Sanitary Consultants
 907 MISSION AVE, SAN RAFAEL, CA 94901
 T: 415.453.4460 WWW.NUTE.BIZ

Designed: BEO
 Drawn: BEO
 Checked: MTW
 Scale: 1" = 1000'
 THESE PLANS ARE NOT TO SCALE.

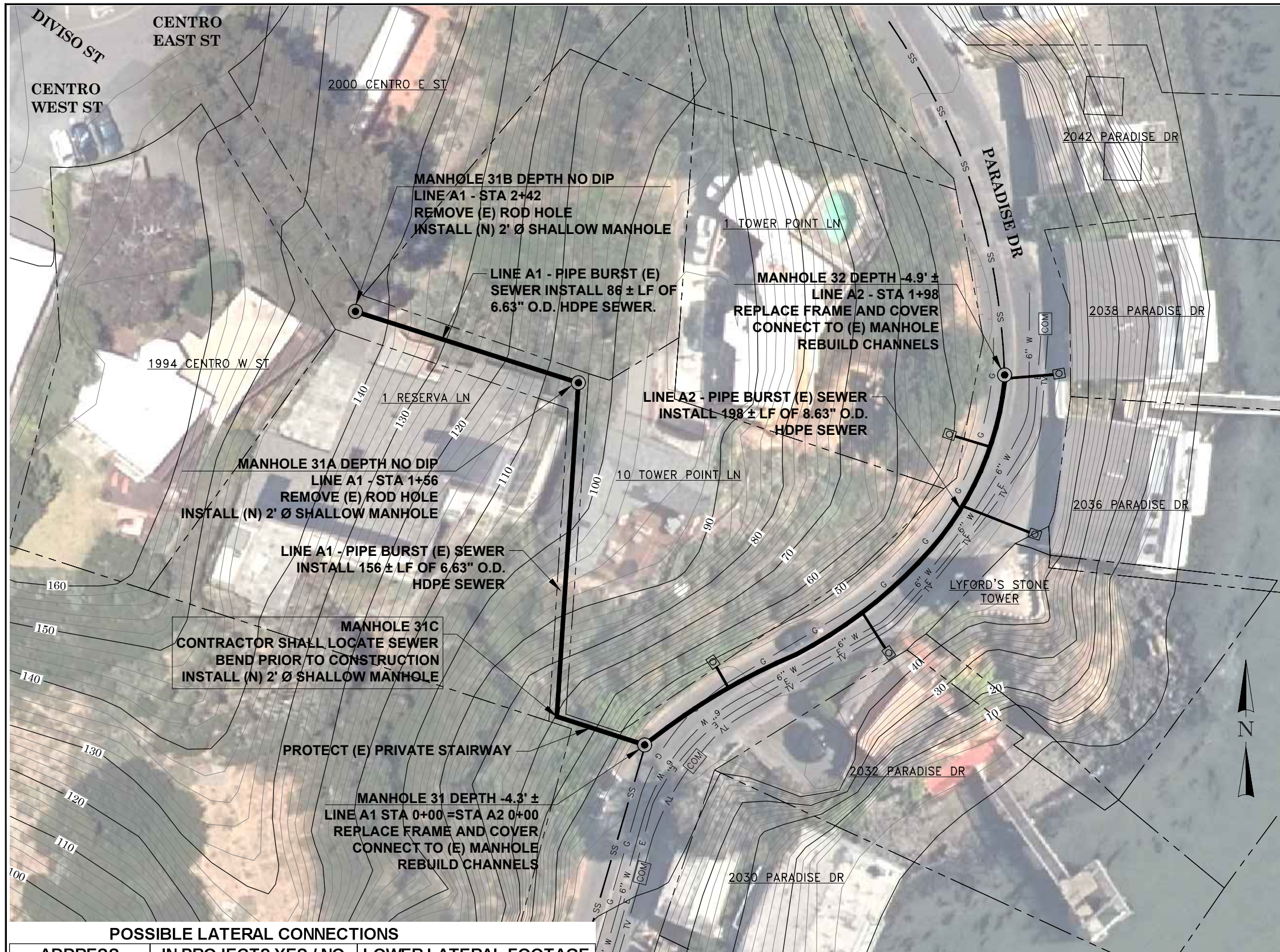
NO.	DESCRIPTION	DATE	INIT.
1			
2			
3			
4			
5			



STRUCTURE NOTE: THIS LINE CONTAINS A STRUCTURE THAT HAS BEEN BURIED OR COVERED, AND WAS UNABLE TO BE FIELD LOCATED. CONTRACTOR TO CCTV AND LOCATE SEWER, MANHOLE AND ROD HOLE WITH GREEN PAINT IN THE STREET OR GREEN FLAGGING IN LANDSCAPE AREA PRIOR TO REHABILITATION WORK.

LATERAL NOTE: SERVICE LATERALS ARE APPROXIMATE LOCATIONS OR THEY ARE NOT SHOWN. THE CONTRACTOR SHALL ASSUME THERE IS AT LEAST ONE SERVICE LATERAL PER BUILDING AND SHALL LOCATE ALL SERVICE LATERALS BY INTERNAL TELEVISION OF SEWER MAIN PRIOR TO PIPEBURSTING. AFTER INSTALLATION OF THE PIPE. THE CONTRACTOR SHALL RECONNECT EACH LATERAL WITHOUT EXCEPTION .

CAUTION: CONTRACTOR SHALL IDENTIFY LOCATION OF HIGH VOLTAGE OVERHEAD ELECTRICAL LINES AND PLACE WARNING SIGNS PER CAL-OSHA REQUIREMENTS.

- NOTES**
1. CONTRACTOR SHALL NOTIFY ALL RESIDENTS OF HOMES AND BUSINESS SHOWN ON THIS PAGE TWO WEEKS IN ADVANCE OF ANY WORK ON THIS PROJECT BY LETTER DOOR HANGER.
 2. CONTRACTOR SHOULD NOTE THAT THEY WORKING IN BACKYARDS WITH LIVE ANIMALS (PETS) IN THE YARDS. KEEP ALL GATES CLOSED.
 3. DUE TO SLOPE OF PIPE, SLOPE DISTANCE IS DIFFERENT THAN PLAN VIEW DISTANCE.
 4. CONTRACTOR TO EXPECT ROCKY CONDITIONS WHILE WORKING ON THIS LINE.
 5. VERIFY SEWER MAIN IS 4" DIAMETER AND VCP MATERIAL, BETWEEN MANHOLE 31 AND 31A IS 4" VCP

MANHOLE 31C
CONTRACTOR SHALL LOCATE SEWER BEND PRIOR TO CONSTRUCTION
INSTALL (N) 2' Ø SHALLOW MANHOLE

PROTECT (E) PRIVATE STAIRWAY

MANHOLE 31 DEPTH -4.3' ±
LINE A1 STA 0+00 = STA A2 0+00
REPLACE FRAME AND COVER
CONNECT TO (E) MANHOLE
REBUILD CHANNELS

POSSIBLE LATERAL CONNECTIONS

ADDRESS	IN PROJECT? YES / NO	LOWER LATERAL FOOTAGE
2000 CENTRO E ST	YES / NO / RECONNECT ONLY	INSTALLED FOOTAGE _____
1994 CENTRO W ST	YES / NO / RECONNECT ONLY	INSTALLED FOOTAGE _____
1 RESERVA LN	YES / NO / RECONNECT ONLY	INSTALLED FOOTAGE _____
1 TOWER POINT LN	YES / NO / RECONNECT ONLY	INSTALLED FOOTAGE _____
10 TOWER POINT LN	YES / NO / RECONNECT ONLY	INSTALLED FOOTAGE _____
2042 PARADISE DR	YES / NO / RECONNECT ONLY	INSTALLED FOOTAGE _____
2038 PARADISE DR	YES / NO / RECONNECT ONLY	INSTALLED FOOTAGE _____
2036 PARADISE DR	YES / NO / RECONNECT ONLY	INSTALLED FOOTAGE _____
2032 PARADISE DR	YES / NO / RECONNECT ONLY	INSTALLED FOOTAGE _____
2030 PARADISE DR	YES / NO / RECONNECT ONLY	INSTALLED FOOTAGE _____

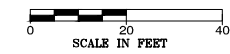

NOT APPROVED
FOR CONSTRUCTION

SANITARY DISTRICT No. 5
2024 SEWER REHABILITATION PROJECT
PARADISE DRIVE AND EASEMENT
PIPE BURSTING PLAN
LINE A1 AND LINE A2

JOB NUMBER: **9173**
DATE: **October 14, 2024**
PAGE: **8** OF **18**

JURISDICTION
TOWN OF TIBURON

NO.	DESCRIPTION	DATE	INIT.
1			
2			
3			
4			
5			

DESIGNED BY	BE0	BE0	MTW
DRAWN BY			
CHECKED BY			

PREPARED BY: **NUTE**
Civil and Sanitary Consultants
907 MISSION AVE, SAN RAFAEL, CA 94901
T: 415.453.4460 WWW.NUTE.BIZ

PREPARED FOR: **SANITARY DISTRICT No. 5**
200 PARADISE DRIVE
TIBURON, CA 94920
PHONE: (415) 455-1501
FAX: (415) 455-0221
CALIFORNIA
MARIN COUNTY

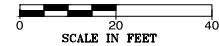
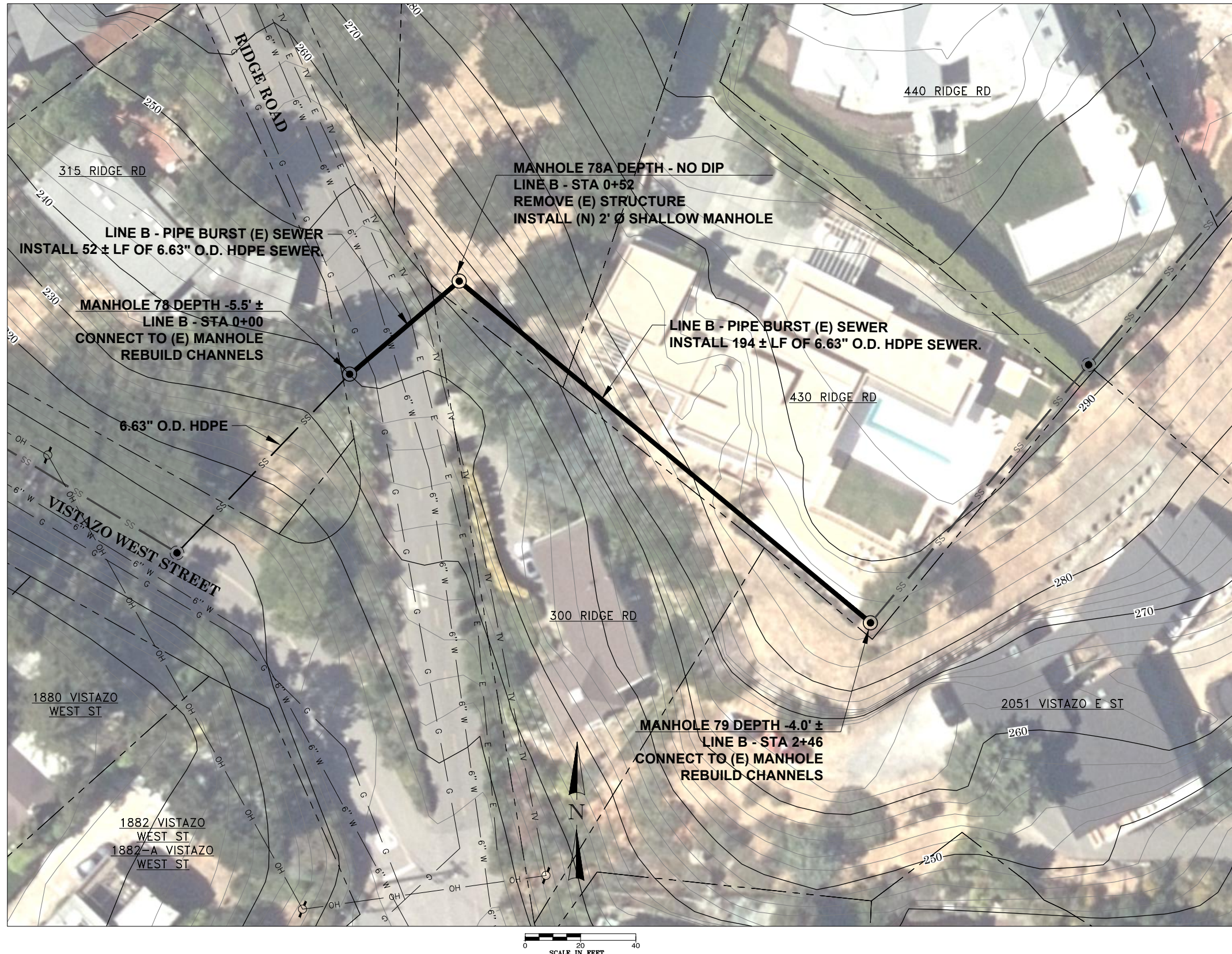

POSSIBLE LATERAL CONNECTIONS

ADDRESS	IN PROJECT? YES / NO	LOWER LATERAL FOOTAGE
300 RIDGE RD	YES / NO / RECONNECT ONLY	INSTALLED FOOTAGE _____
315 RIDGE RD	YES / NO / RECONNECT ONLY	INSTALLED FOOTAGE _____
430 RIDGE RD	YES / NO / RECONNECT ONLY	INSTALLED FOOTAGE _____
2051 VISTAZO E ST	YES / NO / RECONNECT ONLY	INSTALLED FOOTAGE _____

STRUCTURE NOTE: THIS LINE CONTAINS A STRUCTURE THAT HAS BEEN BURIED OR COVERED, AND WAS UNABLE TO BE FIELD LOCATED. CONTRACTOR TO CCTV AND LOCATE SEWER, MANHOLE AND ROD HOLE WITH GREEN PAINT IN THE STREET OR GREEN FLAGGING IN LANDSCAPE AREA PRIOR TO REHABILITATION WORK.

LATERAL NOTE: SERVICE LATERALS ARE NOT SHOWN ON THE PLANS. THE CONTRACTOR SHALL ASSUME THERE IS AT LEAST ONE SERVICE LATERAL PER BUILDING AND SHALL LOCATE ALL SERVICE LATERALS BY INTERNAL TELEVISION OF SEWER MAIN PRIOR TO PIPEBURSTING. AFTER INSTALLATION OF THE PIPE, THE CONTRACTOR SHALL RECONNECT EACH LATERAL WITHOUT EXCEPTION.

CAUTION: CONTRACTOR SHALL IDENTIFY LOCATION OF HIGH VOLTAGE OVERHEAD ELECTRICAL LINES AND PLACE WARNING SIGNS PER CAL-OSHA REQUIREMENTS.

NOTES

- CONTRACTOR SHALL NOTIFY ALL RESIDENTS OF HOMES AND BUSINESS SHOWN ON THIS PAGE TWO WEEKS IN ADVANCE OF ANY WORK ON THIS PROJECT BY LETTER DOOR HANGER.
- CONTRACTOR SHOULD NOTE THAT THEY WILL BE WORKING IN BACKYARDS WITH LIVE ANIMALS (PETS) IN THE YARDS. KEEP ALL GATES CLOSED.
- CONTRACTOR TO RESTORE ANY AND ALL CONCRETE CURB AND GUTTER IF DAMAGED DURING CONSTRUCTION.
- DUE TO SLOPE OF PIPE, SLOPE DISTANCE IS DIFFERENT THAN PLAN VIEW DISTANCE.
- CONTRACTOR TO EXPECT ROCKY CONDITIONS WHILE WORKING ON THIS LINE.

**NOT APPROVED
FOR CONSTRUCTION**

**SANITARY DISTRICT No. 5
2024 SEWER REHABILITATION PROJECT**
RIDGE ROAD EASEMENT
PIPE BURSTING PLAN
LINE B - STA 0+00 TO STA 2+46

JOB NUMBER: **9173**
DATE: **October 14, 2024**
PAGE: **9 OF 18**

**JURISDICTION
TOWN OF TIBURON**

NOT APPROVED FOR CONSTRUCTION

PREPARED FOR: **SANITARY DISTRICT No. 5**
2007 PARADISE DRIVE
TIBURON, CA 94920
PHONE: (415) 435-1501
FAX: (415) 435-0221

PREPARED BY: **NUTE**
Civil and Sanitary Consultants
907 MISSION AVE, SAN RAFAEL, CA 94901
T: 415.453.4460 WWW.NUTE.BIZ

NO.	DATE	DESCRIPTION	INIT.
1			
2			
3			
4			

DESIGNED: BEO
DRAWN: BEO
CHECKED: MTW
SCALE: 1" = 40' (SEE NOTES FOR MORE INFORMATION, THESE PLANS ARE NOT TO SCALE.)

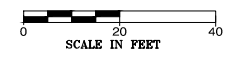
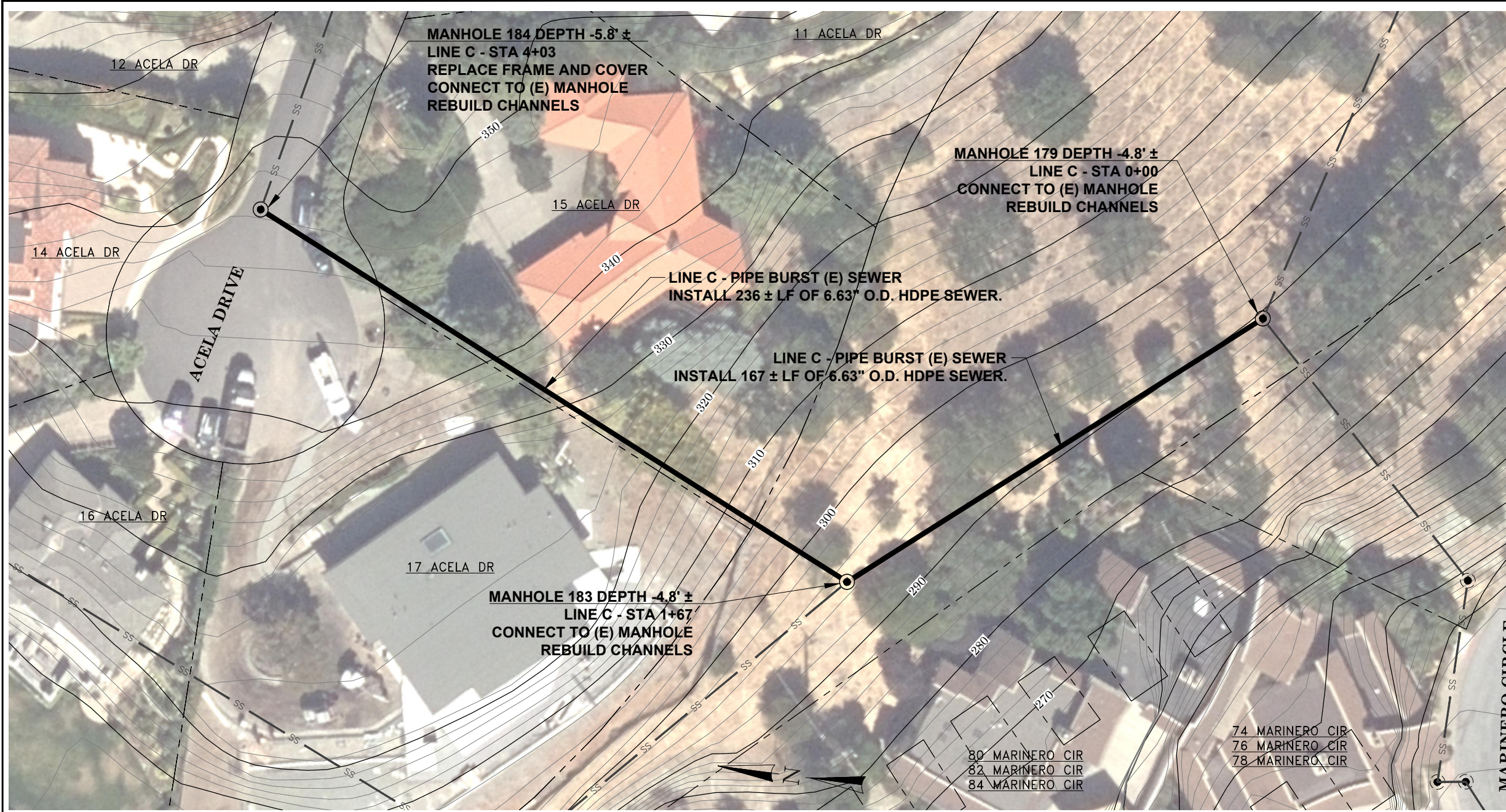

LATERAL NOTE: SERVICE LATERALS ARE NOT SHOWN ON THE PLANS. THE CONTRACTOR SHALL ASSUME THERE IS AT LEAST ONE SERVICE LATERAL PER BUILDING AND SHALL LOCATE ALL SERVICE LATERALS BY INTERNAL TELEVISION OF SEWER MAIN PRIOR TO PIPEBURSTING. AFTER INSTALLATION OF THE PIPE, THE CONTRACTOR SHALL RECONNECT EACH LATERAL WITHOUT EXCEPTION.

CAUTION: CONTRACTOR SHALL IDENTIFY LOCATION OF HIGH VOLTAGE OVERHEAD ELECTRICAL LINES AND PLACE WARNING SIGNS PER CAL-OSHA REQUIREMENTS.

- NOTES**
- CONTRACTOR SHALL NOTIFY ALL RESIDENTS OF HOMES SHOWN ON THIS PAGE TWO WEEKS IN ADVANCE OF ANY WORK ON THIS PROJECT BY LETTER DOOR HANGER.
 - CONTRACTOR SHOULD NOTE THAT THEY ARE WORKING IN BACKYARDS WITH LIVE ANIMALS (PETS) IN THE YARDS. KEEP ALL GATES CLOSED.
 - DUE TO SLOPE OF PIPE, SLOPE DISTANCE IS DIFFERENT THAN PLAN VIEW DISTANCE.
 - CONTRACTOR TO EXPECT ROCKY CONDITIONS WHILE WORKING ON THIS LINE.

POSSIBLE LATERAL CONNECTIONS

ADDRESS	IN PROJECT? YES / NO	LOWER LATERAL FOOTAGE
11 ACELA DR	YES / NO / RECONNECT ONLY	INSTALLED FOOTAGE _____
12 ACELA DR	YES / NO / RECONNECT ONLY	INSTALLED FOOTAGE _____
14 ACELA DR	YES / NO / RECONNECT ONLY	INSTALLED FOOTAGE _____
15 ACELA DR	YES / NO / RECONNECT ONLY	INSTALLED FOOTAGE _____
16 ACELA DR	YES / NO / RECONNECT ONLY	INSTALLED FOOTAGE _____
17 ACELA DR	YES / NO / RECONNECT ONLY	INSTALLED FOOTAGE _____

**NOT APPROVED
FOR CONSTRUCTION**

**SANITARY DISTRICT No. 5
2024 SEWER REHABILITATION PROJECT**
ACELA DRIVE EASEMENT
PIPE BURSTING PLAN
LINE C - STA 0+00 TO STA 4+03

JOB NUMBER: **9173**
DATE: **October 14, 2024**
PAGE: **10** OF **18**

**JURISDICTION
TOWN OF TIBURON**

PREPARED FOR: **SANITARY DISTRICT No. 5**
2007 PARADISE DRIVE
TIBURON, CA 94920
PHONE: (415) 435-1501
FAX: (415) 435-0221
MARIN COUNTY CALIFORNIA

PREPARED BY: **NUTE**
Civil and Sanitary Consultants
907 MISSION AVE, SAN RAFAEL, CA 94901
T: 415.453.4460 WWW.NUTE.BIZ

DESIGNED: _____
DRAWN: _____
CHECKED: _____
DATE: _____

BE0: _____
BEO: _____
MTW: _____

1" = 40' (VERTICAL SCALE)
1" = 40' (HORIZONTAL SCALE)
IF DIMENSIONS DIFFER, THESE PLANS ARE NOT TO SCALE.

NO.	DESCRIPTION	INIT.
1		
2		
3		
4		

P:_Projects\9173 SD5 2024 Sewer Rehab\CAD\9173 SD5-Sewer Plan-Tib.dwg

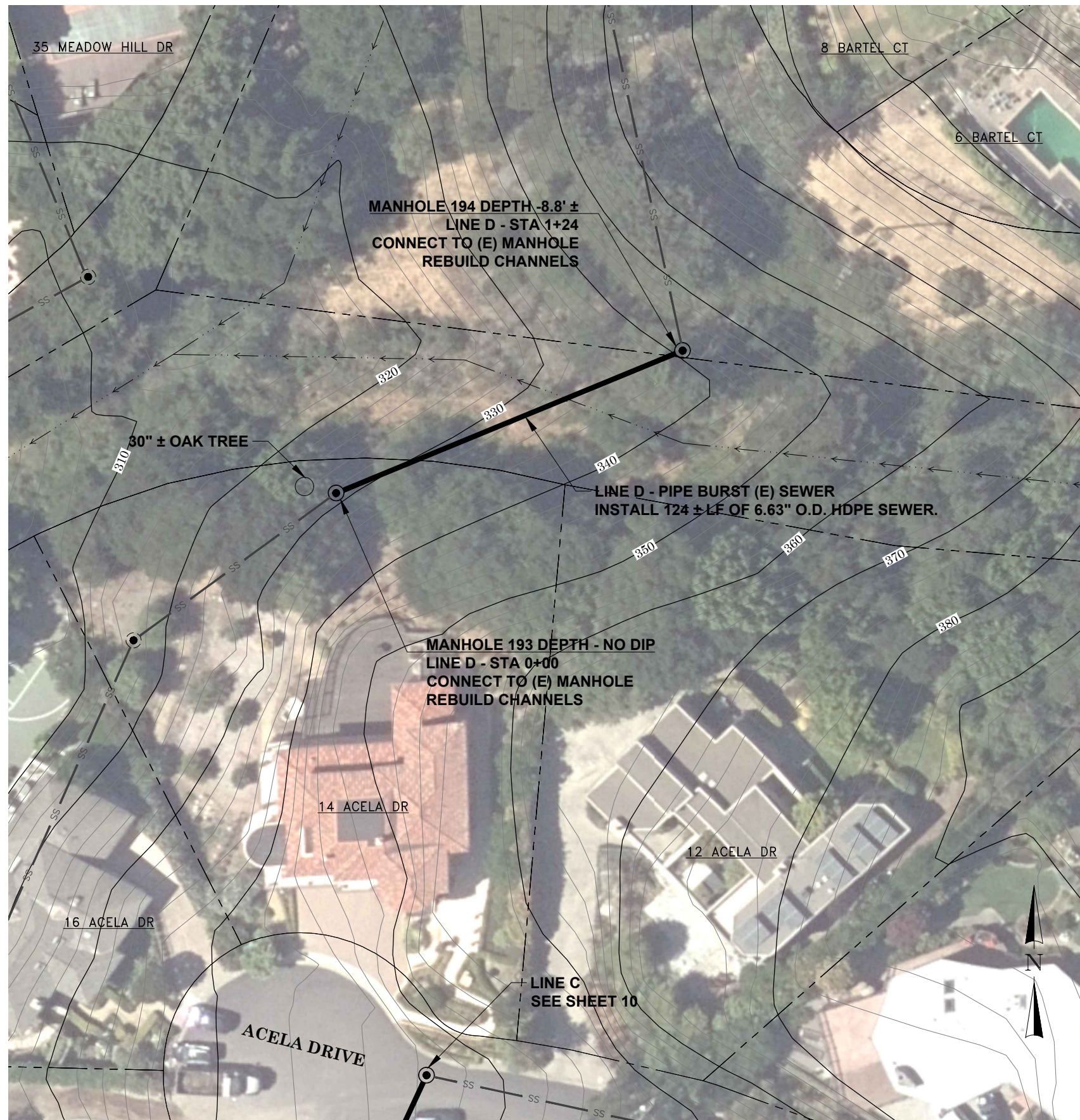

LATERAL NOTE: SERVICE LATERALS ARE NOT SHOWN ON THE PLANS. THE CONTRACTOR SHALL ASSUME THERE IS AT LEAST ONE SERVICE LATERAL PER BUILDING AND SHALL LOCATE ALL SERVICE LATERALS BY INTERNAL TELEVISION OF SEWER MAIN PRIOR TO PIPEBURSTING. AFTER INSTALLATION OF THE PIPE. THE CONTRACTOR SHALL RECONNECT EACH LATERAL WITHOUT EXCEPTION.

CAUTION: CONTRACTOR SHALL IDENTIFY LOCATION OF HIGH VOLTAGE OVERHEAD ELECTRICAL LINES AND PLACE WARNING SIGNS PER CAL-OSHA REQUIREMENTS.

- NOTES**
1. CONTRACTOR SHALL NOTIFY ALL RESIDENTS OF HOMES SHOWN ON THIS PAGE TWO WEEKS IN ADVANCE OF ANY WORK ON THIS PROJECT BY LETTER DOOR HANGER.
 2. CONTRACTOR SHOULD NOTE THAT THEY ARE WORKING IN BACKYARDS WITH LIVE ANIMALS (PETS) IN THE YARDS. KEEP ALL GATES CLOSED.
 3. DUE TO SLOPE OF PIPE, SLOPE DISTANCE IS DIFFERENT THAN PLAN VIEW DISTANCE.
 4. CONTRACTOR TO EXPECT ROCKY CONDITIONS WHILE WORKING ON THIS LINE.

**NOT APPROVED
FOR CONSTRUCTION**

POSSIBLE LATERAL CONNECTIONS

ADDRESS	IN PROJECT? YES / NO	LOWER LATERAL FOOTAGE
6 BARTEL CT	YES / NO / RECONNECT ONLY	INSTALLED FOOTAGE _____
8 BARTEL CT	YES / NO / RECONNECT ONLY	INSTALLED FOOTAGE _____
12 ACELA DR	YES / NO / RECONNECT ONLY	INSTALLED FOOTAGE _____
14 ACELA DR	YES / NO / RECONNECT ONLY	INSTALLED FOOTAGE _____

**JURISDICTION
TOWN OF TIBURON**

NOT APPROVED FOR CONSTRUCTION

**SANITARY DISTRICT No. 5
2024 SEWER REHABILITATION PROJECT
ACELA DRIVE EASEMENT
PIPE BURSTING PLAN
LINE D - STA 0+00 TO STA 1+24**

PREPARED FOR:  SANITARY DISTRICT No. 5
2007 PARADISE DRIVE
TIBURON, CA 94920
PHONE: (415) 435-1501
FAX: (415) 435-0221
MARIN COUNTY CALIFORNIA

PREPARED BY:  **NUTE**
Civil and Sanitary Consultants
907 MISSION AVE, SAN RAFAEL, CA 94901
T: 415.453.4460 WWW.NUTE.BIZ

NO.	DESCRIPTION	DATE	INIT.
1			
2			
3			
4			

DESIGNED BY: BEO
DRAWN BY: BEO
CHECKED BY: MTW
DATE: 10/14/2024
SCALE: 1" = 40'-0"
IF DIMENSIONS NOT TO SCALE, THESE PLANS ARE NOT TO SCALE.

JOB NUMBER: **9173**
DATE: **October 14, 2024**
PAGE: **11** OF **18**

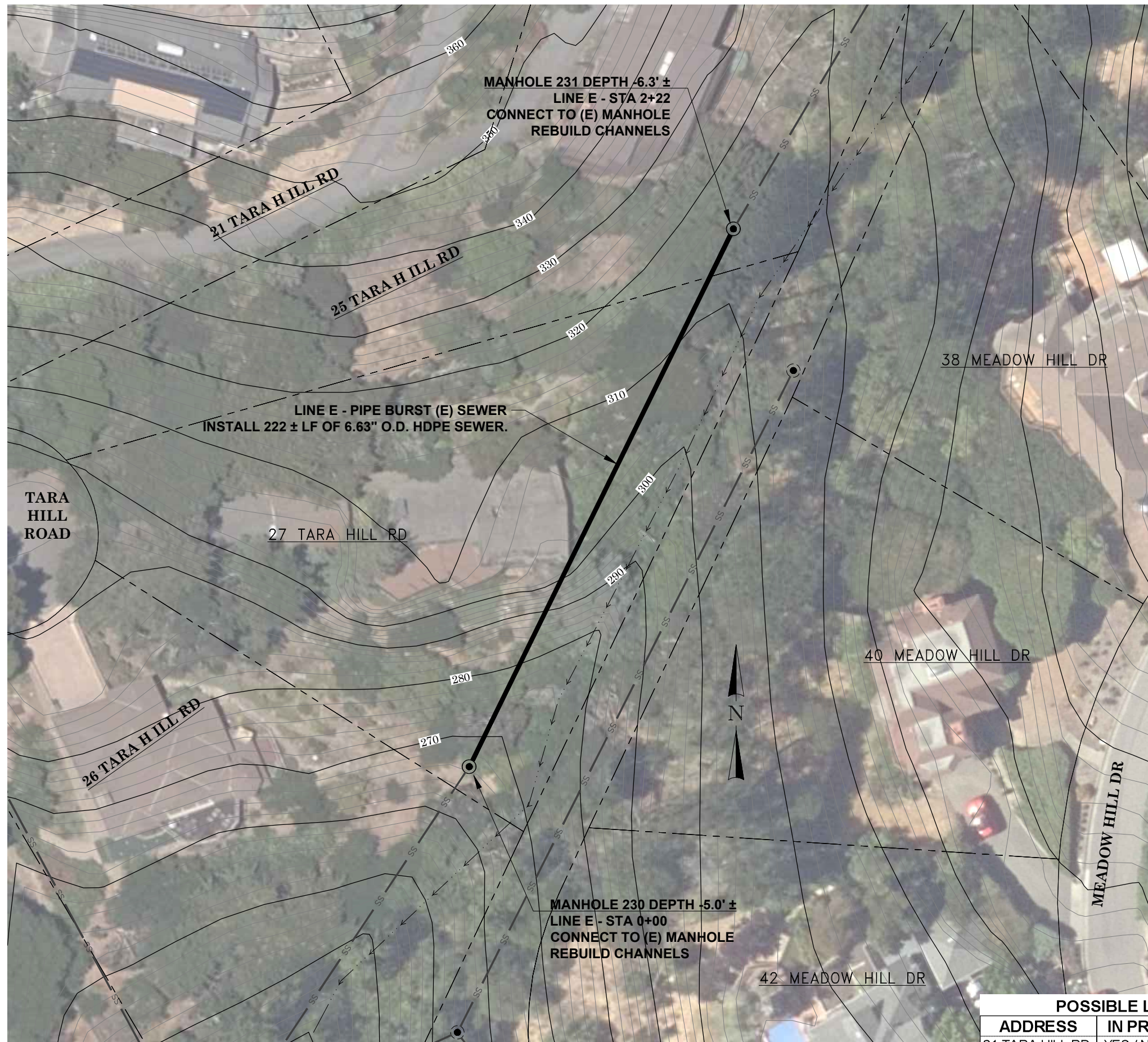

LATERAL NOTE: SERVICE LATERALS ARE NOT SHOWN ON THE PLANS. THE CONTRACTOR SHALL ASSUME THERE IS AT LEAST ONE SERVICE LATERAL PER BUILDING AND SHALL LOCATE ALL SERVICE LATERALS BY INTERNAL TELEVISION OF SEWER MAIN PRIOR TO PIPEBURSTING. AFTER INSTALLATION OF THE PIPE. THE CONTRACTOR SHALL RECONNECT EACH LATERAL WITHOUT EXCEPTION .

CAUTION: CONTRACTOR SHALL IDENTIFY LOCATION OF HIGH VOLTAGE OVERHEAD ELECTRICAL LINES AND PLACE WARNING SIGNS PER CAL-OSHA REQUIREMENTS.

- NOTES**
1. CONTRACTOR SHALL NOTIFY ALL RESIDENTS OF HOMES SHOWN ON THIS PAGE TWO WEEKS IN ADVANCE OF ANY WORK ON THIS PROJECT BY LETTER DOOR HANGER.
 2. CONTRACTOR SHOULD NOTE THAT THEY ARE WORKING IN BACKYARDS WITH LIVE ANIMALS (PETS) IN THE YARDS. KEEP ALL GATES CLOSED.
 3. DUE TO SLOPE OF PIPE, SLOPE DISTANCE IS DIFFERENT THAN PLAN VIEW DISTANCE.
 4. CONTRACTOR TO EXPECT ROCKY CONDITIONS WHILE WORKING ON THIS LINE.

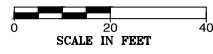

POSSIBLE LATERAL CONNECTIONS		
ADDRESS	IN PROJECT? YES / NO	LOWER LATERAL FOOTAGE
21 TARA HILL RD	YES / NO / RECONNECT ONLY	INSTALLED FOOTAGE _____
25 TARA HILL RD	YES / NO / RECONNECT ONLY	INSTALLED FOOTAGE _____
26 TARA HILL DR	YES / NO / RECONNECT ONLY	INSTALLED FOOTAGE _____
27 TARA HILL DR	YES / NO / RECONNECT ONLY	INSTALLED FOOTAGE _____

**NOT APPROVED
FOR CONSTRUCTION**

SANITARY DISTRICT No. 5
2024 SEWER REHABILITATION PROJECT
 TARA HILL ROAD EASEMENT
 PIPE BURSTING PLAN
 LINE E - STA 0+00 TO STA 2+22

JOB NUMBER: **9173**
 DATE: **October 14, 2024**
 JURISDICTION: **TOWN OF TIBURON**
 PAGE: **12** OF **18**

PREPARED FOR: **SANITARY DISTRICT No. 5**
 2007 PARADISE DRIVE
 TIBURON, CA 94920
 PHONE: (415) 435-1501
 FAX: (415) 435-0221
 MARIN COUNTY CALIFORNIA

PREPARED BY: **NUTE**
 Civil and Sanitary Consultants
 907 MISSION AVE, SAN RAFAEL, CA 94901
 T: 415.453.4460 WWW.NUTE.BIZ

NO.	DATE	DESCRIPTION	INIT.
1			
2			
3			
4			

NOTES

1. CONTRACTOR SHALL NOTIFY ALL RESIDENTS OF HOMES SHOWN ON THIS PAGE TWO WEEKS IN ADVANCE OF ANY WORK ON THIS PROJECT BY LETTER DOOR HANGER.
2. CONTRACTOR SHOULD NOTE THAT THEY ARE WORKING IN BACKYARDS WITH LIVE ANIMALS (PETS) IN THE YARDS. KEEP ALL GATES CLOSED.
3. DUE TO SLOPE OF PIPE, SLOPE DISTANCE IS DIFFERENT THAN PLAN VIEW DISTANCE.
4. CONTRACTOR TO EXPECT ROCKY CONDITIONS WHILE WORKING ON THIS LINE.

POSSIBLE LATERAL CONNECTIONS

ADDRESS	IN PROJECT? YES / NO	LOWER LATERAL FOOTAGE
11 MOUNT TIBURON RD	YES / NO / RECONNECT ONLY	INSTALLED FOOTAGE _____
35 MOUNT TIBURON RD	YES / NO / RECONNECT ONLY	INSTALLED FOOTAGE _____
77 MOUNT TIBURON RD	YES / NO / RECONNECT ONLY	INSTALLED FOOTAGE _____
81 MOUNT TIBURON RD	YES / NO / RECONNECT ONLY	INSTALLED FOOTAGE _____
83 MOUNT TIBURON RD	YES / NO / RECONNECT ONLY	INSTALLED FOOTAGE _____
85 MOUNT TIBURON RD	YES / NO / RECONNECT ONLY	INSTALLED FOOTAGE _____
101 MOUNT TIBURON RD	YES / NO / RECONNECT ONLY	INSTALLED FOOTAGE _____

LATERAL NOTE: SERVICE LATERALS ARE NOT SHOWN ON THE PLANS. THE CONTRACTOR SHALL ASSUME THERE IS AT LEAST ONE SERVICE LATERAL PER BUILDING AND SHALL LOCATE ALL SERVICE LATERALS BY INTERNAL TELEVISION OF SEWER MAIN PRIOR TO PIPEBURSTING. AFTER INSTALLATION OF THE PIPE, THE CONTRACTOR SHALL RECONNECT EACH LATERAL WITHOUT EXCEPTION.
CAUTION: CONTRACTOR SHALL IDENTIFY LOCATION OF HIGH VOLTAGE OVERHEAD ELECTRICAL LINES AND PLACE WARNING SIGNS PER CAL-OSHA REQUIREMENTS.

FIELD NOTE: POSSIBLE 2ND LATERAL (POOL DRAIN POSSIBLE) FOR 77 MOUNT TIBURON RD NEED TO REVIEW CCTV

**LINE F - PIPE BURST (E) SEWER
INSTALL 178 ± LF OF 6.63" O.D. HDPE SEWER.**

**MANHOLE 272 DEPTH -6.0' ±
LINE F - STA 1+96
CONNECT TO (E) MANHOLE
REBUILD CHANNELS**

**LINE F - PIPE BURST (E) SEWER
INSTALL 196 ± LF OF 6.63" O.D. HDPE SEWER.**

**MANHOLE 274 DEPTH -5.6' ±
LINE F - STA 5+99
CONNECT TO (E) MANHOLE
REBUILD CHANNELS**

**MANHOLE IS IN LANDSCAPING WITH A 3'
ROCK WALL SURROUNDING HALF OF IT.**

**LINE F - PIPE BURST (E) SEWER
INSTALL 179 ± LF OF 6.63" O.D. HDPE SEWER.**

**MANHOLE 271 DEPTH -5.2' ±
LINE F - STA 0+00
REPLACE FRAME AND COVER
CONNECT TO (E) MANHOLE
REBUILD CHANNELS**

**MANHOLE 275 DEPTH -5.0' ±
LINE F - STA 7+38
CONNECT TO (E) MANHOLE
REBUILD CHANNELS**

**MANHOLE IN LANDSCAPE AREA.
CONTRACTOR TO PROTECT AND RESTORE
ANY DAMAGED LANDSCAPING.**

**MANHOLE 273 DEPTH -8.3' ±
LINE F - STA 3+74
CONNECT TO (E) MANHOLE
REBUILD CHANNELS**

**MANHOLE IS IN
CONCRETE DRIVEWAY**

NO.	DATE	DESCRIPTION

DESIGNED BY	BEO
DRAWN BY	BEO
CHECKED BY	NTW
SCALE	1" = 100'
DATE	

PREPARED BY:
NUTE
 Civil and Sanitary Consultants
 907 MISSION AVE, SAN RAFAEL, CA 94901
 T: 415.453.4460 WWW.NUTE.DIZ

PREPARED FOR:
SANITARY DISTRICT No. 5
 200 PARADISE DRIVE
 TIBURON, CA 94920
 PHONE: (415) 455-1501
 FAX: (415) 455-0221
 MARIN COUNTY CALIFORNIA

2024 SEWER REHABILITATION PROJECT
MOUNT TIBURON ROAD EASEMENT
PIPE BURSTING PLAN
LINE F - STA 0+00 TO STA 7+38

JOB NUMBER: **9173**
 DATE: **October 14, 2024**
 PAGE: **13** OF **18**

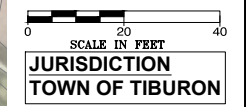

**NOT APPROVED
FOR CONSTRUCTION**

P:_Projects\9173 SD5 2024 Sewer Rehab\CAD\9173 SD5-Sewer Plan-Tib.dwg

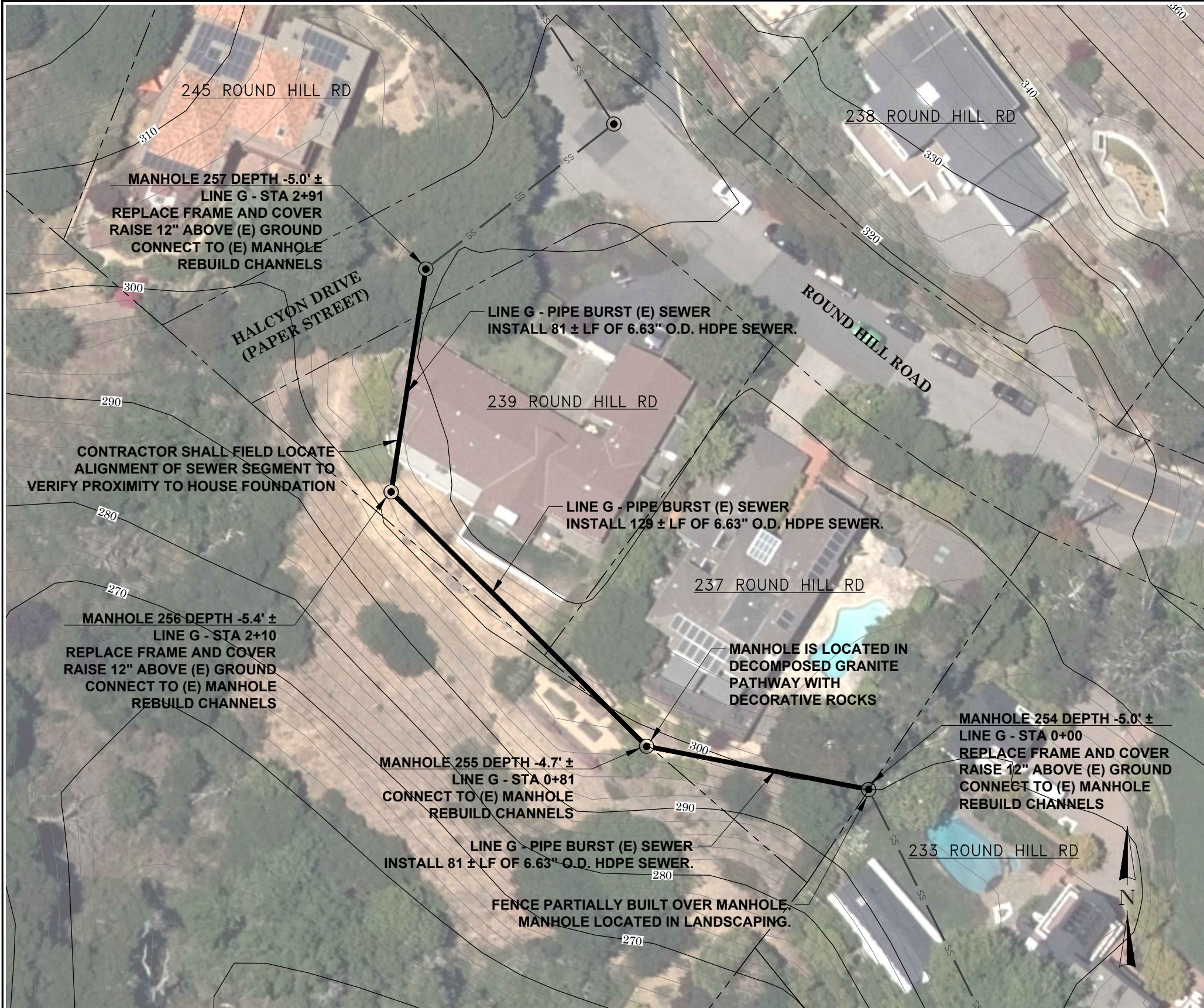

LATERAL NOTE: SERVICE LATERALS ARE NOT SHOWN ON THE PLANS. THE CONTRACTOR SHALL ASSUME THERE IS AT LEAST ONE SERVICE LATERAL PER BUILDING AND SHALL LOCATE ALL SERVICE LATERALS BY INTERNAL TELEVISION OF SEWER MAIN PRIOR TO PIPEBURSTING. AFTER INSTALLATION OF THE PIPE, THE CONTRACTOR SHALL RECONNECT EACH LATERAL WITHOUT EXCEPTION .

CAUTION: CONTRACTOR SHALL IDENTIFY LOCATION OF HIGH VOLTAGE OVERHEAD ELECTRICAL LINES AND PLACE WARNING SIGNS PER CAL-OSHA REQUIREMENTS.

- NOTES**
1. CONTRACTOR SHALL NOTIFY ALL RESIDENTS OF HOMES SHOWN ON THIS PAGE TWO WEEKS IN ADVANCE OF ANY WORK ON THIS PROJECT BY LETTER DOOR HANGER.
 2. CONTRACTOR SHOULD NOTE THAT THEY ARE WORKING IN BACKYARDS WITH LIVE ANIMALS (PETS) IN THE YARDS. KEEP ALL GATES CLOSED.
 3. MANHOLE 255 IS LOCATED IN A DECOMPOSED GRANITE PATHWAY THAT HAS DECORATIVE ROCKS FOR ITS BORDER.
 4. MANHOLE 254 IS LOCATED IN LANDSCAPING WITH A FENCE BUILT OVER THE TOP OF IT.
 5. CONTRACTOR TO EXPECT ROCKY CONDITIONS WHILE WORKING ON THIS LINE.

POSSIBLE LATERAL CONNECTIONS

ADDRESS	IN PROJECT? YES / NO	LOWER LATERAL
233 ROUND HILL RD	YES / NO / RECONNECT ONLY	INSTALLED FOOTAGE
237 ROUND HILL RD	YES / NO / RECONNECT ONLY	INSTALLED FOOTAGE
238 ROUND HILL RD	YES / NO / RECONNECT ONLY	INSTALLED FOOTAGE
239 ROUND HILL RD	YES / NO / RECONNECT ONLY	INSTALLED FOOTAGE
245 ROUND HILL RD	YES / NO / RECONNECT ONLY	INSTALLED FOOTAGE

**NOT APPROVED
FOR CONSTRUCTION**

	NO.	DESCRIPTION	DATE	INIT.
	1			
	2			
	3			
	4			
	5			

DESIGNED BY:	BEO	BEO	MTW	
DRAWN BY:	Check	Check	Check	1" = 40' (SEE NOTES FOR SCALE)

PREPARED BY:

NUTE
Civil and Sanitary Consultants
907 MISSION AVE, SAN RAFAEL, CA 94901
T: 415.453.4460 WWW.NUTE.BIZ

PREPARED FOR:

SANITARY DISTRICT No. 5
200 PARADISE DRIVE
TIBURON, CA 94920
PHONE: (415) 435-1501
FAX: (415) 435-0221

PREPARED FOR:

SANITARY DISTRICT No. 5
2024 SEWER REHABILITATION PROJECT
ROUND HILL ROAD EASEMENT
PIPE BURSTING PLAN
LINE G - STA 0+00 TO STA 2+91

JURISDICTION
TOWN OF TIBURON

JOB NUMBER: **9173**
DATE: October 14, 2024
PAGE: **14** OF **18**



MANHOLE CB9 DEPTH -3.8' ±
LINE H - STA 2+14
REPLACE FRAME AND COVER
CONNECT TO (E) MANHOLE
REBUILD CHANNELS

MANHOLE CB8 DEPTH -4.5' ±
LINE H - STA 0+00
REPLACE FRAME AND COVER
CONNECT TO (E) MANHOLE
REBUILD CHANNELS

LINE H - PIPE BURST (E) SEWER
INSTALL 214 ± LF OF 6.63" O.D.
HDPE SEWER.

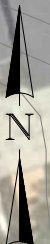
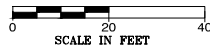

LATERAL NOTE: SERVICE LATERALS ARE NOT SHOWN ON THE PLANS. THE CONTRACTOR SHALL ASSUME THERE IS AT LEAST ONE SERVICE LATERAL PER BUILDING AND SHALL LOCATE ALL SERVICE LATERALS BY INTERNAL TELEVISION OF SEWER MAIN PRIOR TO PIPEBURSTING. AFTER INSTALLATION OF THE PIPE, THE CONTRACTOR SHALL RECONNECT EACH LATERAL WITHOUT EXCEPTION .

CAUTION: CONTRACTOR SHALL IDENTIFY LOCATION OF HIGH VOLTAGE OVERHEAD ELECTRICAL LINES AND PLACE WARNING SIGNS PER CAL-OSHA REQUIREMENTS.

- NOTES**
- CONTRACTOR SHALL NOTIFY ALL RESIDENTS OF HOMES SHOWN ON THIS PAGE TWO WEEKS IN ADVANCE OF ANY WORK ON THIS PROJECT BY LETTER DOOR HANGER.
 - DUE TO SLOPE OF PIPE, SLOPE DISTANCE IS DIFFERENT THAN PLAN VIEW DISTANCE.

NO.	DESCRIPTION	DATE	INIT.

DESIGNED BY	DRAWN BY	CHECKED BY	DATE

PREPARED BY: **NIJTE**
 Civil and Sanitary Consultants
 907 MISSION AVE, SAN RAFAEL, CA 94901
 T: 415.453.4460 WWW.NIJTE.BIZ

PREPARED FOR: **SANITARY DISTRICT No. 5**
 2007 PARADISE DRIVE
 TIBURON, CA 94920
 PHONE: (415) 435-1501
 FAX: (415) 435-0221
 MARIN COUNTY CALIFORNIA

NOT APPROVED FOR CONSTRUCTION

JURISDICTION
 TOWN OF BELVEDERE

SANITARY DISTRICT No. 5
2024 SEWER REHABILITATION PROJECT
BRITTON AVENUE TO GOLDEN GATE AVENUE
PIPE BURSTING PLAN
LINE H - STA 0+00 TO STA 2+14

POSSIBLE LATERAL CONNECTIONS

ADDRESS	IN PROJECT? YES / NO	LOWER LATERAL FOOTAGE
1 BRITTON AVE	YES / NO / RECONNECT ONLY	INSTALLED FOOTAGE _____
2 BRITTON AVE	YES / NO / RECONNECT ONLY	INSTALLED FOOTAGE _____
3 BRITTON AVE	YES / NO / RECONNECT ONLY	INSTALLED FOOTAGE _____

JOB NUMBER: **9173**
 DATE: **October 14, 2024**
 PAGE: **15** OF **18**

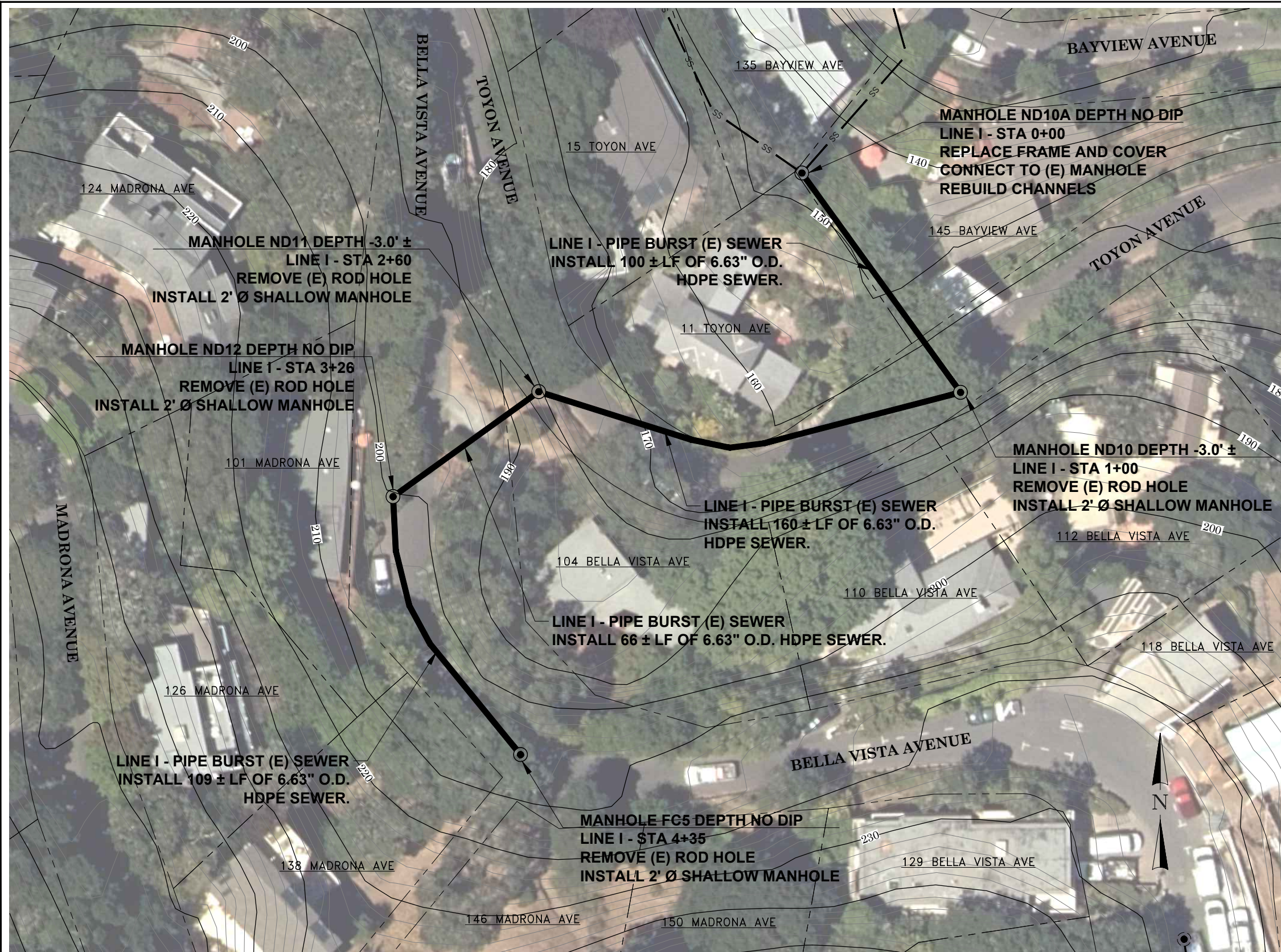

STRUCTURE NOTE: THIS LINE CONTAINS A STRUCTURE THAT HAS BEEN BURIED OR COVERED, AND WAS UNABLE TO BE FIELD LOCATED. CONTRACTOR TO CCTV AND LOCATE SEWER, MANHOLE AND ROD HOLE WITH GREEN PAINT IN THE STREET OR GREEN FLAGGING IN LANDSCAPE AREA PRIOR TO REHABILITATION WORK.

LATERAL NOTE: SERVICE LATERALS ARE NOT SHOWN ON THE PLANS. THE CONTRACTOR SHALL ASSUME THERE IS AT LEAST ONE SERVICE LATERAL PER BUILDING AND SHALL LOCATE ALL SERVICE LATERALS BY INTERNAL TELEVISION OF SEWER MAIN PRIOR TO PIPEBURSTING. AFTER INSTALLATION OF THE PIPE. THE CONTRACTOR SHALL RECONNECT EACH LATERAL WITHOUT EXCEPTION .

CAUTION: CONTRACTOR SHALL IDENTIFY LOCATION OF HIGH VOLTAGE OVERHEAD ELECTRICAL LINES AND PLACE WARNING SIGNS PER CAL-OSHA REQUIREMENTS.

- NOTES**
1. CONTRACTOR SHALL NOTIFY ALL RESIDENTS OF HOMES SHOWN ON THIS PAGE TWO WEEKS IN ADVANCE OF ANY WORK ON THIS PROJECT BY LETTER DOOR HANGER.
 2. CONTRACTOR SHOULD NOTE THAT HE IS WORKING IN BACKYARDS WITH LIVE ANIMALS (PETS) IN THE YARDS. KEEP ALL GATES CLOSED.
 3. DUE TO SLOPE OF PIPE, SLOPE DISTANCE IS DIFFERENT THAN PLAN VIEW DISTANCE.
 4. MANHOLE ND10A HAS A WOOD RETAINING WALL AND 8 FT FENCE PARTIALLY SURROUNDING THE MANHOLE.

NO.	DESCRIPTION	DATE	INIT.

DESIGNED BY:	BEO
DRAWN BY:	BEO
CHECKED BY:	MTW
DATE:	11/15/2024

PREPARED BY: **NUTE**
 Civil and Sanitary Consultants
 907 MISSION AVE, SAN RAFAEL, CA 94901
 T: 415.453.4460 WWW.NUTE.BIZ

PREPARED FOR: **SANITARY DISTRICT No. 5**
 200 PARADISE DRIVE
 TIBURON, CA 94920
 PHONE: (415) 435-1501
 FAX: (415) 435-0221
 MARIN COUNTY CALIFORNIA

NOT APPROVED FOR CONSTRUCTION

**SANITARY DISTRICT No. 5
 2024 SEWER REHABILITATION PROJECT
 BELLA VISTA AVENUE TO TOYON AVENUE
 PIPE BURSTING PLAN
 LINE I - STA 0+00 TO STA 4+35**

JOB NUMBER: **9173**
 DATE: **October 14, 2024**
 PAGE: **16** OF **18**

POSSIBLE LATERAL CONNECTIONS

ADDRESS	IN PROJECT? YES / NO	LOWER LATERAL FOOTAGE
101 MADRONA AVE	YES / NO / RECONNECT ONLY	INSTALLED FOOTAGE
124 MADRONA AVE	YES / NO / RECONNECT ONLY	INSTALLED FOOTAGE
126 MADRONA AVE	YES / NO / RECONNECT ONLY	INSTALLED FOOTAGE
138 MADRONA AVE	YES / NO / RECONNECT ONLY	INSTALLED FOOTAGE
146 MADRONA AVE	YES / NO / RECONNECT ONLY	INSTALLED FOOTAGE
150 MADRONA AVE	YES / NO / RECONNECT ONLY	INSTALLED FOOTAGE
104 BELLA VISTA AVE	YES / NO / RECONNECT ONLY	INSTALLED FOOTAGE
110 BELLA VISTA AVE	YES / NO / RECONNECT ONLY	INSTALLED FOOTAGE

POSSIBLE LATERAL CONNECTIONS

ADDRESS	IN PROJECT? YES / NO	LOWER LATERAL FOOTAGE
112 BELLA VISTA AVE	YES / NO / RECONNECT ONLY	INSTALLED FOOTAGE
118 BELLA VISTA AVE	YES / NO / RECONNECT ONLY	INSTALLED FOOTAGE
129 BELLA VISTA AVE	YES / NO / RECONNECT ONLY	INSTALLED FOOTAGE
11 TOYON AVE	YES / NO / RECONNECT ONLY	INSTALLED FOOTAGE
15 TOYON AVE	YES / NO / RECONNECT ONLY	INSTALLED FOOTAGE
135 BAYVIEW AVE	YES / NO / RECONNECT ONLY	INSTALLED FOOTAGE
145 BAYVIEW AVE	YES / NO / RECONNECT ONLY	INSTALLED FOOTAGE

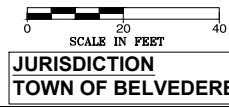



- NOTES**
- CONTRACTOR SHALL NOTIFY ALL RESIDENTS OF HOMES SHOWN ON THIS PAGE TWO WEEKS IN ADVANCE OF ANY WORK ON THIS PROJECT BY LETTER DOOR HANGER.
 - DUE TO SLOPE OF PIPE, SLOPE DISTANCE IS DIFFERENT THAN PLAN VIEW DISTANCE.

STRUCTURE NOTE: THIS LINE CONTAINS A STRUCTURE THAT HAS BEEN BURIED OR COVERED, AND WAS UNABLE TO BE FIELD LOCATED. CONTRACTOR TO CCTV AND LOCATE SEWER, MANHOLE AND ROD HOLE WITH GREEN PAINT IN THE STREET OR GREEN FLAGGING IN LANDSCAPE AREA PRIOR TO REHABILITATION WORK.

LATERAL NOTE: SERVICE LATERALS ARE NOT SHOWN ON THE PLANS. THE CONTRACTOR SHALL ASSUME THERE IS AT LEAST ONE SERVICE LATERAL PER BUILDING AND SHALL LOCATE ALL SERVICE LATERALS BY INTERNAL TELEVISION OF SEWER MAIN PRIOR TO PIPEBURSTING. AFTER INSTALLATION OF THE PIPE, THE CONTRACTOR SHALL RECONNECT EACH LATERAL WITHOUT EXCEPTION.

NO.	DESCRIPTION	DATE	INIT.

DESIGNED BY: BEO
 DRAWN BY: BEO
 CHECKED BY: MTW
 SCALE: 1" = 100'-0" (SEE NOTES FOR DETAILS)
 THESE PLANS ARE NOT TO SCALE.

PREPARED BY: **NUITE**
 Civil and Sanitary Consultants
 907 MISSION AVE, SAN RAFAEL, CA 94901
 T: 415.453.4460 WWW.NUIITE.BIZ

PREPARED FOR: **SANITARY DISTRICT No. 5**
 2007 PARADISE DRIVE
 TIBURON, CA 94920
 PHONE: (415) 435-1501
 FAX: (415) 435-0221
 MARIN COUNTY CALIFORNIA

APPROVED INSTRUCTION

SANITARY DISTRICT No. 5
2024 SEWER REHABILITATION PROJECT
EUCALYPTUS ROAD
PIPE BURSTING PLAN
LINE J - STA 0+00 TO STA 2+51

POSSIBLE LATERAL CONNECTIONS

ADDRESS	IN PROJECT? YES / NO	LOWER LATERAL FOOTAGE
137 GOLDEN GATE AVE	YES / NO / RECONNECT ONLY	INSTALLED FOOTAGE _____
201 GOLDEN GATE AVE	YES / NO / RECONNECT ONLY	INSTALLED FOOTAGE _____
205 GOLDEN GATE AVE	YES / NO / RECONNECT ONLY	INSTALLED FOOTAGE _____
209 GOLDEN GATE AVE	YES / NO / RECONNECT ONLY	INSTALLED FOOTAGE _____
19 EUCALYPTUS RD	YES / NO / RECONNECT ONLY	INSTALLED FOOTAGE _____
26 EUCALYPTUS RD	YES / NO / RECONNECT ONLY	INSTALLED FOOTAGE _____
28 EUCALYPTUS RD	YES / NO / RECONNECT ONLY	INSTALLED FOOTAGE _____
30 EUCALYPTUS RD	YES / NO / RECONNECT ONLY	INSTALLED FOOTAGE _____

JURISDICTION
TOWN OF BELVEDERE

P:_Projects\9173 SD5 2024 Sewer Rehab\CAD\9173 SD5-Sewer Plan-Bel.dwg

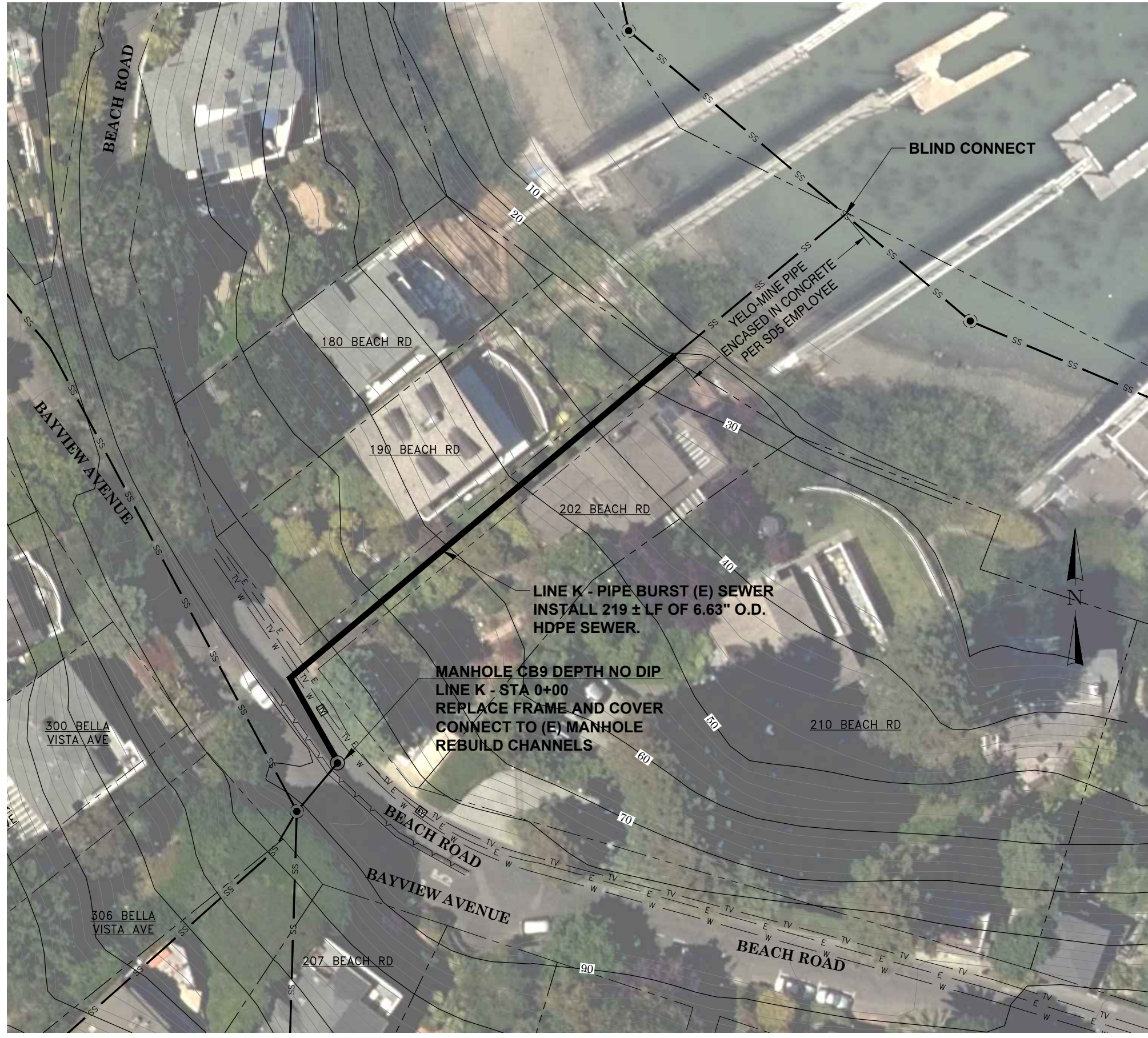

- NOTES**
1. CONTRACTOR SHALL NOTIFY ALL RESIDENTS OF HOMES SHOWN ON THIS PAGE TWO WEEKS IN ADVANCE OF ANY WORK ON THIS PROJECT BY LETTER DOOR HANGER.
 2. CONTRACTOR SHOULD NOTE THAT HE IS WORKING IN BACKYARDS WITH LIVE ANIMALS (PETS) IN THE YARDS. KEEP ALL GATES CLOSED.
 3. DUE TO SLOPE OF PIPE, SLOPE DISTANCE IS DIFFERENT THAN PLAN VIEW DISTANCE.

STRUCTURE NOTE: THIS LINE CONTAINS A STRUCTURE THAT HAS BEEN BURIED OR COVERED, AND WAS UNABLE TO BE FIELD LOCATED. CONTRACTOR TO CCTV AND LOCATE SEWER, MANHOLE AND ROD HOLE WITH GREEN PAINT IN THE STREET OR GREEN FLAGGING IN LANDSCAPE AREA PRIOR TO REHABILITATION WORK.

LATERAL NOTE: SERVICE LATERALS ARE NOT SHOWN ON THE PLANS. THE CONTRACTOR SHALL ASSUME THERE IS AT LEAST ONE SERVICE LATERAL PER BUILDING AND SHALL LOCATE ALL SERVICE LATERALS BY INTERNAL TELEVISION OF SEWER MAIN PRIOR TO PIPEBURSTING. AFTER INSTALLATION OF THE PIPE, THE CONTRACTOR SHALL RECONNECT EACH LATERAL WITHOUT EXCEPTION .

NO.	DATE	DESCRIPTION	INIT.
1			
2			
3			

DESIGNED BY: BEO
 DRAWN BY: BEO
 CHECKED BY: MTW
 SCALE: 1" = 40'-0" (SEE NOTES FOR SCALE)
 PREPARED BY: **NUTE**
 Civil and Sanitary Consultants
 907 MISSION AVE, SAN RAFAEL, CA 94901
 T: 415.453.4460 WWW.NUTE.BIZ

PREPARED FOR: **SANITARY DISTRICT No. 5**
 200 PARADISE DRIVE
 TIBURON, CA 94920
 PHONE: (415) 455-1501
 FAX: (415) 455-0221
 MARIN COUNTY CALIFORNIA

NOT APPROVED FOR CONSTRUCTION

SANITARY DISTRICT No. 5
2024 SEWER REHABILITATION PROJECT
 BEACH ROAD EASEMENT
 PIPE BURSTING PLAN
 LINE K STA 0+00 TO STA 2+19

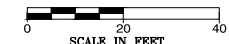

JURISDICTION
 TOWN OF BELVEDERE

JOB NUMBER: **9173**
 DATE: **October 14, 2024**
 PAGE: **18** OF **18**

SANITARY DISTRICT NO. 5

Marin County, California

CONTRACT DOCUMENTS

and

SPECIFICATIONS

FOR THE CONSTRUCTION OF THE

**2024 SEWER REHABILITATION PROJECT
TIBURON AND BELVEDERE**

Omar Arias-Montez – President
John Carapiet – Vice-President
Richard Snyder – Board Secretary
Tod Moody – Director
Catherine Benediktsson – Director

Tony Rubio – District Manager

NUTE ENGINEERING

907 Mission Avenue
San Rafael, California
Tel: (415) 453-4480
Fax: (415) 453-0343

NOVEMBER 2024

THIS PAGE INTENTIONALLY LEFT BLANK

Sanitary District No. 5
2024 SEWER REHABILITATION PROJECT
TIBURON AND BELVEDERE

TABLE OF CONTENTS

DIVISION 0 - BIDDING AND CONTRACT REQUIREMENTS	<u>PAGE NUMBER</u>
00010 Notice Inviting Bids	00010-1
00100 Instructions to Bidders	00100-1
00200 Information Available to Bidders	00200-1
00300 Bid Form	00300-1
00310 Bid Schedule	00310-1
00410 Bidder's Bond	00410-1
00430 Designation of Subcontractors	00430-1
00440 Site Visit Affidavit	00440-1
00450 Schedule of Major Equipment and Material Supplies, Products Identified by Name and Substitutions	00450-1
00458 Certification of Drug-Free Workplace Requirements	00458-1
00460 Certification of Bidder's Experience and Qualifications	00460-1
00480 Non-collusion Affidavit	00480-1
00490 Affidavit of Safety Compliance	00490-1
00500 Agreement	00500-1
00610 Faithful Performance Bond	00610-1
00620 Payment Bond	00620-1
00630 Escrow Agreement for Security Deposits in Lieu of Retention	00630-1
00650 General Liability Endorsement	00650-1
00651 Auto Liability Endorsement	00651-1
00700 General Conditions	00700-1
1.0 General	00700-1
1.1 Contract Agreement	00700-1
1.2 Written Notice and Service Thereof	00700-2
1.3 Rights of Action	00700-2

1.4	Plans and Specifications	00700-2
1.5	Applicability of all Paragraphs of Specifications	00700-3
1.6	Contract Interpretation by the Construction Manager	00700-3
1.7	Order of Precedence	00700-4
1.8	Bonds	00700-4
1.9	Penalty for Collusion	00700-5
1.10	Rights and Remedies	00700-5
2.0	Contract Administration	00700-5
2.1	Administration of the Contract	00700-5
2.2	Owner's Representative	00700-6
2.3	Construction Manager	00700-6
2.4	Design Consultant	00700-7
3.0	Owner	00700-8
3.1	General	00700-8
3.2	Attention to Work	00700-8
3.3	Observation and Inspection	00700-9
3.4	Owner's Right to Use or Occupy	00700-9
3.5	Owner's Right to Carry Out the Work	00700-9
3.6	Owner's Right to Perform Work and to Award Separate Contracts	00700-10
3.7	Responsibility of the Owner	00700-10
4.0	Contractor	00700-10
4.1	Status of Contractor and Subcontractors	00700-10
4.2	Contractor's Representative	00700-10
4.3	Use of Owner's Site	00700-11
4.4	Fees and Permits	00700-11
4.5	Compliance with Laws	00700-11
4.6	Compliance with Environmental Laws	00700-13
4.7	Safety	00700-13
4.8	Provisions for Handling Emergencies	00700-18
4.9	Nonstandard Working Hours	00700-18
4.10	Cooperation with Other Contractors	00700-18
5.0	Control of Work and Material	00700-19
5.1	Means, Methods and Appliances	00700-19
5.2	Character of Workers	00700-19
5.3	Materials and Workmanship	00700-19
5.4	Existing Utilities	00700-20
6.0	Progress of the Work	00700-21
6.1	Commencement of Work	00700-21
6.2	Contract Time	00700-21
6.3	Delays	00700-22
6.4	Time Extensions	00700-23
6.5	Liquidated Damages	00700-25
6.6	Suspension of Work	00700-25
6.7	Right to Terminate Contract	00700-26

7.0	Changes in the Work	00700-27
7.1	Change Orders	00700-27
7.2	Differing Site Conditions	00700-28
7.3	Resolution of Disputes	00700-28
8.0	Payment	00700-32
8.1	Basis of Payment	00700-32
8.2	Partial Payments	00700-33
8.3	Right to Withhold Amounts	00700-36
8.4	Security Substitution for Withholds	00700-36
8.5	Warranty of Title	00700-37
8.6	Substantial Completion	00700-38
8.7	Early Occupancy	00700-38
8.8	Final Inspection and Payment	00700-39
00800	Supplementary General Conditions	00800-1
1.0	Modifications to the General Conditions	00800-1
1.1	Time Allowed for Completion	00800-1
1.2	Damages for Delays	00800-1
1.3	Weather Days	00800-1
1.4	Contract Administration	00800-1
2.0	Liability and Insurance	00800-2
2.1	Insurance	00800-2
2.2	Insurance During Guarantee Period	00800-7
3.0	Not Used	00800-7
4.0	Not Used	00800-7
5.0	Substantial Completion	00800-7
01010	Summary of Work	
01025	Measurement and Payment	
01030	Special Conditions	
01035	Modification Procedures	
01090	References	
01200	Project Meetings	
01310	Progress Schedule	
01340	Shop Drawings, Product Data and Samples	
01400	Quality Control	
01510	Temporary Utilities	
01560	Temporary Controls	
01601	Materials and Equipment	

- 01720 Project Record Documents**
- 01740 Warranties and Bonds**
- 02055 Demolition and Abandonment of Lines and Structures**
- 02200 Excavation and Backfill**
- 02500 Surface Restoration**
- 02602 Trenchless Pipe Replacement**
- 02605 Manholes**
- 02659 Cleaning and Video Inspection**

**APPENDIX A – EXAMPLE PERMIT CONDITIONS
Town of Tiburon**

**APPENDIX B – EXAMPLE PERMIT CONDITIONS
City of Belvedere**

SECTION 00010

NOTICE INVITING BIDS

Notice is hereby given that sealed bids will be received by the District Manager of the Sanitary District No. 5, at the District office, 2001 Paradise Drive, Tiburon CA 94920, at any time prior to **2:00 PM on [REDACTED], 2024** for furnishing all labor, materials, equipment, and services for the construction of improvements designated as:

2024 Sewer Rehabilitation Project
Tiburon and Belvedere

Any bids received after the scheduled closing time for receipt of bids shall be returned unopened. Bids will be publicly opened, examined and declared on said day and hour, and will be referred to the District Board of Directors for subsequent action.

The successful bidder will have one hundred twenty (120) consecutive calendar days to substantially complete the project from the Notice to Proceed.

All of said work is to be done at the places and in the particular locations, of the form, sizes and dimensions and of the materials, and to the lines and grades and at the elevations as shown on the plans and specifications made therefor and approved by the Owner.

The Owner hereby advises all bidders that the successful bidder shall:

1. Employ the appropriate number of apprentices on the job site as set forth in California Labor Code 1777.5;
2. Provide Workers' Compensation coverage, as set forth in California Labor Code Sections 1860 and 1861;
3. Keep and maintain the records of work performed on the public works project, as set forth in California Labor Code Section 1812;
4. Keep and maintain the records required under California Labor Code Section 1776 which shall be subject to inspection pursuant to California Labor Code Section 1776 and California Code of Regulations, Division 1, Chapter 8, Subchapter 3, Article 6, Section 16400 (e); and
5. Be subject to other requirements imposed by law.

CALIFORNIA WAGE RATE REQUIREMENTS: In accordance with the provisions of the California Labor Code Sections 1770, 1773, 1773.1, 1773.6 and 1773.7 as amended, the Director of the Department of Industrial Relations has determined the general prevailing rate of per diem wages in accordance with the standards set forth in Section 1773 for the locality in which the Work is to be performed. A copy of said wage rates is available on-line at www.dir.ca.gov/DLSR/PWD. It shall be mandatory upon the Contractor to whom the Work is awarded and upon any subcontractor to pay not less than said specified rates to all workers employed by them in the execution of the Work.

Said prevailing rate of per diem wages will be made available to any interested party upon

request, and a copy thereof shall be posted at the job site by the Contractor.

No contractor or subcontractor may be listed on a bid proposal for a public works project unless registered with the Department of Industrial Relations pursuant to Labor Code section 1725.5 [with limited exceptions from this requirement for bid purposes only under Labor Code section 1771.1(a)].

No contractor or subcontractor may be awarded a contract for public work on a public works project unless registered with the Department of Industrial Relations pursuant to Labor Code section 1725.5.

The Owner will not recognize any claim for additional compensation because of the payment by the contractor of any wage rate in excess of the prevailing wage rates on file as aforesaid. The possibility of a wage increase is one of the elements to be considered by the contractor in determining his/her or its bid and will not, under any circumstances, be considered as the basis of a claim against the Owner on the contract.

Pursuant to the provisions of California Labor Code Section 6707, each bid submitted in response to this Notice Inviting Bids shall contain, as a bid item, adequate sheeting, shoring, and bracing, or equivalent method, for the protection of life and limb in trenches and open excavation, which shall conform to applicable safety orders. By listing this sum, the bidder warrants that its action does not convey tort liability to the Owner, the Design Consultant, the Construction Manager, and their employees, agents, and subconsultants.

The successful bidder and its subcontractors shall employ workers, trades and craftsmen which constantly display and demonstrate proper moral, ethical and professional conduct to all fellow workers, employees and representatives of the Owner and other involved entities.

Bidders may obtain copies of the bidding documents by logging on to or by calling BPXpress Reprographics at (510) 559-8299 or emailing Richmond@blueprintexpress.com. There is a non-refundable FEE of \$60 PER SET for a printed package. Shipping and handling costs are extra and prices depend on the delivery method. At the bidder's request and expense, the Contract Documents may be sent by overnight mail. Bidders can supply their shipper account number to expedite processing. Electronic bidding documents can also be ordered for a non-refundable FEE of \$50 PER SET. All bidders must purchase a complete set (hard copy or complete download) from BPXpress Printing & Graphics to be included on the planholder's list and to receive addenda notifications. **It is the responsibility of each prospective bidder to confirm his/her firm is on the planholder's list held at BPXpress Printing & Graphics to ensure receipt of any subsequent communications, such as Addenda.** Partial sets of Bid Documents are not available from the Owner or Engineer.

Each bid must conform and be responsive to the invitation, the Plans and Specifications, and all documents comprising the Contract Documents. Each bid shall be presented under sealed cover and shall be accompanied by a certified check or bidder's bond, made payable to the Owner, in an amount not less than ten percent (10%) of the bid. The said check or bidder's bond shall be given as a guarantee that the successful bidder will execute the contract in conformity with the form of agreement contained within the contract documents, and will furnish bonds and insurance policies as specified within ten (10) days after notification

of the award of the Contract to the successful bidder. The contract documents that the

successful bidder must submit within ten (10) days of notification of award include, but are not limited to, a payment or labor and materials bond in an amount of at least 100 percent of the amount payable by the terms of the project contract and that satisfies the requirements of California Civil Code Section 3248, and a performance bond in an amount of at least 100 percent of the amount payable by the terms of the contract. All project bonds must be executed by an admitted surety insurer in accordance with applicable law and acceptable to the Owner.

Cost for work described in each addenda issued during the time of bidding shall be included in the Bid and the addenda shall become a part of the Contract documents.

Bidders shall develop and submit bids at their own expense. The Owner will not reimburse any costs associated with the development and submittal of any and all Bids.

In accordance with California Public Contract Code Section 3400, bidders may propose equals of products listed in the plans and specifications by manufacturer name, brand or model number, unless the technical specifications or plans specify that the product is only available from one source, or is necessary to match others in use.

The Owner reserves the sole right to reject any or all bids and to waive any informality in a bid.

No bidder may withdraw its bid for a period of sixty (60) calendar days after the date set for the opening thereof. The Bidder shall guarantee the total bid price for a period of sixty (60) calendar days from the date of bid opening.

At the successful Contractor's option, securities may be substituted for the required retention, in accordance with the provisions of Section 22300 of the State of California Public Contract Code.

In accordance with the provisions of California Public Contract Code Section 3300, the Owner has determined that the Contractor shall possess, as a minimum, a valid Class A License. In accordance with the provisions of California Business and Professions Code Section 7028.15, a bid submitted to the Owner by a Contractor who is not licensed in accordance with Chapter 9 of the California Business and Professions Code shall be considered non-responsive and shall be rejected by the Owner.

Questions concerning this project should be submitted in writing via regular mail, email, or fax and directed to:

Mark Wilson
Nute Engineering
907 Mission Avenue
San Rafael, CA 94901
Tel: (415) 453-4480

By: 

Tony Rubio, District Manager
Sanitary District No. 5

Date: _____

THIS PAGE INTENTIONALLY LEFT BLANK

SECTION 00100

INSTRUCTIONS TO BIDDERS

1.0 GENERAL

The work to be performed is described in the Contract Documents titled, 2024 Sewer Rehabilitation Project - Tiburon and Belvedere, Codes and standards, definitions of words and terms, and abbreviations shall be as specified in Section 01090, References.

All bidders shall carefully examine the Contract Documents and satisfy themselves as to their sufficiency; and shall not at any time after the submission of the bid dispute or complain of such Contract Documents and the directions explaining them or interpreting them, nor assert that there is any misunderstanding in regard to the location, extent, nature of amount of work to be performed. The bidder shall notify the Owner of any discovered conflicts, errors of discrepancies in the Contract Documents prior to the submission of its bid. Intended bidders shall have visited the site of the work and familiarized themselves with the conditions there existing as well as all other conditions relating the construction and labor under which the work will be performed and affecting cost, progress or performance of the work. The submitting of a bid shall be considered an acknowledgement on the part of the Bidder of its familiarity with conditions at the site of work.

Bids for the work shall be made on the forms contained in the following sections and shall include the following completed documents:

<u>SECTION</u>	<u>TITLE</u>
00300	BID FORM
00310	BID SCHEDULE
00410	BIDDER'S BOND
00430	DESIGNATION OF SUBCONTRACTORS
00440	PROJECT SITE VISIT AFFIDAVIT
00450	SCHEDULE OF MAJOR EQUIPMENT AND MATERIAL SUPPLIERS, PRODUCTS IDENTIFIED BY NAME AND SUBSTITUTION
00458	CERTIFICATION OF DRUG-FREE WORKPLACE REQUIREMENTS
00460	CERTIFICATION OF BIDDER'S EXPERIENCE AND QUALIFICATIONS
00480	NONCOLLUSION AFFIDAVIT
00490	AFFIDAVIT OF SAFETY COMPLIANCE

A complete set of bid forms shall be placed in an envelope, sealed, and addressed to:

SANITARY DISTRICT NO. 5
Attention: District Manager
2001 Paradise Drive
Tiburon, CA 94920
BID: 2024 Sewer Rehabilitation Project
Tiburon and Belvedere

No pre-bid conference will be held for this Re-Bid project.

The Owner reserves the right to postpone the date and time for receiving and/or opening of bids at any time prior to the date and time established in the Notice Inviting Bids in accordance with applicable law. Postponement notices will be sent to planholders of record in the form of addenda.

Addenda may be issued to all known planholders during the Bid period. Any and all addenda issued shall become a part of the Contract Documents and shall be fully considered by all bidders during preparation of bids.

Bids shall give the prices proposed in figures, shall give all other information requested herein, and shall be signed by the bidder or an authorized representative, including address. By submission of a proposal on the separate forms provided by the Owner, the bidder attests that the bidder has purchased a complete set of the project manual and is aware of its entire contents, including any addenda. Bidder is required to provide a complete bid on all schedules listed in Section 00310, **BID SCHEDULE**.

Bids shall be delivered to the Owner at the above address before the time set for the opening of bids as provided in Section 00010, **NOTICE INVITING BIDS**.

After the expiration of the time for submission of bids, all bids will be publicly opened, read, declared, and referred to the City Council for action.

2.0 BID PRICES

Bid prices shall include everything necessary for the completion of construction and fulfillment of the contract. Bid prices shall include all federal, state and local taxes including sales and use taxes. Costs for developing, submitting, and presenting bids are the sole responsibility of the bidder and claims for reimbursement will not be accepted by the Owner.

If the product of a unit price and an estimated quantity does not equal the extended amount quoted, the unit price shall govern, and the correct product of the unit price and the estimate quantity shall be deemed to be the amount bid. If the sum of two or more items in a bidding schedule does not equal the total amounts quoted, the individual item amounts shall govern and the correct total shall be deemed to be the amount of the bid.

3.0 BIDDER'S EXPERIENCE AND QUALIFICATIONS

All Bidders must complete and submit with their Bid Section 00460, **CERTIFICATION OF BIDDER'S EXPERIENCE AND QUALIFICATIONS**. Failure to provide this information with the Bid may render the Bid non-responsive and may be the basis for rejection of the Bid. The information furnished will be reviewed to determine if the Bidder is qualified and responsible to be awarded the Contract.

4.0 BID IRREGULARITIES

Each bid and the information requested shall be enclosed in a sealed envelope and labeled as specified herein. Bidders are warned against making erasures or alterations of any kind, and bids which contain omissions, erasures, or irregularities of any kind may be rejected. No oral, telegraphic, facsimile, or telephonic bids or modifications will be considered.

5.0 MODIFICATION OF BID

Modification of a bid already received will be considered only if the modification is received prior to the time established for receiving bids. Modifications shall be made in writing, executed, and submitted in the same form and manner as the original bid.

6.0 SUBCONTRACTORS AND MAJOR SUPPLIERS

In accordance with California Public Contracting Code Section 4100, et. Seq., each bid shall have listed in Section 00430, **DESIGNATION OF SUBCONTRACTORS**, the name, type or trade, portion of work to be performed, and location of the place of business of each subcontractor who will perform work or labor or render service to the bidder in or about the construction of the work or improvement, or of any subcontractor licensed by the State of California who, under subcontract to the bidder, will specifically fabricate and install a portion of the work or improvement according to detailed drawings contained in the Contract Documents, in an amount in excess of one-half of one percent of the bidder's total bid or \$10,000, whichever is greater.

If the Contractor fails to designate in its proposal a subcontractor for any portion of the work as required above, the bidder shall be deemed to have agreed to perform such portion of the work itself and shall not be permitted to subcontract said portion of the work without the written permission of the Owner in accordance with applicable law.

7.0 BID GUARANTY BOND AND CONTRACT AWARD

Bids shall be accompanied by a cashier's check, a certified check or a bidder's bond executed by an admitted surety in an amount not less than ten (10) percent of the aggregate of the bid, payable to the order of the Owner. Said check or bond shall be a guarantee that the successful bidder, if awarded the work, will within ten (10) days after notice of its award to the successful bidder: (1) enter into a contract, (2) furnish a bond of faithful performance and a labor and material bond, and (3) furnish insurance policies and endorsements. In case of refusal or failure to enter into said Contract, the bid guaranty check or bond, as the case may be, shall be forfeited to the Owner, the proceeds therefrom being hereby agreed upon as liquidated damages to the said Owner on account of the delay in the execution of the Contract and required bonds and the performance of the work thereunder, and the necessity of accepting a higher or less desirable bid resulting from such failure or refusal to execute the Contract and the bonds as required.

Upon the execution of the Contract and the approval on behalf of the Owner of the accompanying bonds and insurance policies and endorsements, all certified checks that accompany Proposals and that have not heretofore been returned, will be returned, each to its maker. If Owner awards a contract, Award of the Contract will be made within sixty (60) days after the opening of bids to the lowest responsive, responsible bidder complying with these instructions, the Section 00010, **NOTICE INVITING BIDS**, and such other pertinent provisions of the Contract Documents as may apply. If award is made, it will be based on the lowest responsive, responsible bid whose base bid and alternate(s) as listed in Section 00300, **BID FORM**, yields the lowest total Contract price. Inclusion of any or all alternates in the contract shall be at the sole discretion of the Owner. The Owner, however, reserves the right to reject any or all bids, and to waive any informality in bids received.

8.0 CONTRACTOR'S LICENSE

Each bidder shall be licensed in accordance with the provisions of the Contractors License Law of California as stipulated in Section 00010, **NOTICE INVITING BIDS**.

9.0 LOCAL BUSINESS LICENSE

The Contractor shall have a local business license from the Town of Tiburon for the work contemplated before the Contract can be executed.

10.0 WORK PERCENTAGES

The Contractor shall perform with its own organization no less than 50% of the work.

11.0 COLLUSION

If the Owner has reason to believe that collusion exists among bidders, the Owner will reject the bids of the known participants in such collusion and may, at its option, require that all bidders certify under penalty of perjury, that no collusion has occurred or exists. The Owner also, at its option, may reject all bids received. In accordance with Public Contract Code Section 7106 the Contractor shall complete and file with its proposal the **Noncollusion Affidavit** in Section 00480. Public Contract Code Section 7106 requires that the affidavit must be duly sworn.

12.0 INTERPRETATIONS

No oral representations or interpretations will be made to any bidder as to the meaning of the Contract Documents. Requests for an interpretation shall be made in writing and delivered to the individual specified in Section 00010, Notice Inviting Bids, at least seven (7) days before the bids are opened as provided in Section 00010, **NOTICE INVITING BIDS**.

13.0 SAFETY COMPLIANCE

The Owner requires that the Contractor conducts its operations in a manner to eliminate or reduce hazards and risks associated with the Contractor's activities, to prevent accidents and injuries, and to prevent property damages. Each Bidder shall certify under penalty of perjury that it will provide evidence that it can comply with the required mandatory Safety Programs delineated in the Affidavit of Safety Compliance contained in Specification Section 00490. The Bidder will be evaluated on the basis of Part E, Evaluation Worksheet.

If the Bidder does not submit an Affidavit of Safety Compliance with the Bid the Bidder may be deemed non-responsive or a non-responsible Bidder, and be disqualified.

If a Bidder submits a completed Contractor's Safety Operations Requirements, Parts A through D that does not meet the minimum requirements outlined in Part E, Evaluation Worksheet, this will also be a basis for disqualification.

14.0 WITHDRAWAL OF BID

In accordance with Public Contract Code 5103, within five days after the opening of bids, a bidder may be permitted to withdraw its bid providing the bidder can establish to the Owner's satisfaction that a mistake was made in preparing the bid. A bidder desiring to withdraw shall

give written notice to the Owner, specifying, in detail, how the mistake occurred and how the mistake made the bid materially different than it was intended to be. Withdrawal will not be permitted for mistakes resulting from errors in judgment or carelessness in inspecting the site of the work or in reading the Contract Documents.

15.0 BID PROTEST

Any Bid protest must be submitted in writing to the District Manager before 5:00 p.m. on the fifth (5th) working day following Bid opening.

- A. The initial protest document must contain a complete statement of the basis for the protest, and all supporting documentation.
- B. The party filing the protest must have actually submitted a Bid for the Work. A subcontractor of a party submitting a Bid for the Work may not submit a Bid protest. A party may not rely on the Bid protest submitted by another Bidder, but must timely pursue its own protest.
- C. The protest must refer to the specific portion of the bid document which forms the basis for the protest.
- D. The protest must include the name, address and telephone number of the person representing the protesting party.
- E. The party filing the protest must concurrently transmit a copy of the initial protest document and any attached documentation to all other parties with a direct financial interest which may be adversely affected by the outcome of the protest. Such parties shall include all other Bidders who appear to have a reasonable prospect of receiving an award depending upon the outcome of the protest.
- F. The Owner will give the protested Bidder five (5) working days after the receipt of the protest to submit a written response. The responding Bidder shall transmit the response to the protesting Bidder concurrent with delivery to the Owner.
- G. The procedure and time limits set forth in this paragraph are mandatory and are the Bidder's sole and exclusive remedy in the event of Bid protest. The Bidder's failure to comply with these procedures shall constitute a waiver of any right to further pursue the Bid protest, including filing a Government Code Claim or legal proceedings
- H. If the Owner determines that a protest is frivolous, the protesting bidder may be determined to be non-responsible and that bidder may be determined to be ineligible for future contract awards.

16.0 OTHER NOTARIZED AFFIDAVITS REQUIRED WITH BID

The submitting of a bid shall be considered an acknowledgement on the part of the Bidder of familiarity with conditions at the site of the Work. The Bidder further acknowledges that the site examination has provided adequate and sufficient information related to existing conditions which may affect cost, progress or performance of the Work.

All Bidders shall submit affidavits, duly sworn and notarized, as presented in Section 00440, **PROJECT SITE VISIT AFFIDAVIT**, that they have visited and familiarized themselves with the Project Site.

The submitting of a bid shall be considered an acknowledgment on the part of the Bidder of familiarity with the Project, and its coordination requirements with this Contract's Work.

17.0 BIDDERS CHECKLIST

This checklist has been prepared and furnished to aid Bidders in including all necessary supporting information with their bid. Bidders' submittals should include, but are not limited to, the following:

<u>Item</u>	<u>Checked</u>
1. Bid Form (Section 00300, pages 1 through 4)	_____
2. Bid Proposal Certificate (Section 00300, pages 5, 6 and 7)	_____
3. Bid Schedule (Section 00310)	_____
4. Bidder's Bond (Section 00410)	_____
5. Designation of Subcontractors (Section 00430)	_____
6. Site Visit Affidavit (Section 00440)	_____
7. Schedule of Major Equipment and Material Suppliers (Section 00450)	_____
8. Certification of Drug-Free Workplace Requirements (Section 00458)	_____
9. Certification of Bidder's Experience and Qualifications (Section 00460)	_____
10. Non-collusion Affidavit (Section 00480)	_____
11. Affidavit of Safety Compliance (Section 00490)	_____

***** END OF SECTION *****

SECTION 00200

INFORMATION AVAILABLE TO BIDDERS

1.0 SITE ACCESS DURING BID PERIOD

Additional access to the site(s) for investigations may be desired to assist the bidders in the development of their bid. This access shall be provided as described in Section 00100-1.0 **GENERAL**.

***** END OF SECTION *****

THIS PAGE INTENTIONALLY LEFT BLANK

SECTION 00300

BID FORM

To the:

Date: _____

Sanitary District No. 5
Attention: District Manager
2001 Paradise Drive
Tiburon, CA 94920

Name of Bidder _____

Business Address _____

The undersigned as bidder declares that it has purchased a complete set of the Project Manual and carefully examined the location of the proposed work, the Contract Documents, and the plans and specifications therein referred to, and the bidder proposes and agrees if this proposal is accepted, that it will contract with the District and hereby proposes to furnish all labor, materials, necessary machinery, tools, apparatus, and other means of construction and services, and do all the work specified in the Contract Documents in the manner and time hereinafter set forth required for the construction of the work involved in the improvements designated as:

2024 Sewer Rehabilitation Project
Tiburon and Belvedere

ADDENDUM RECEIPT: The receipt of the following Addenda to the Contract Documents is acknowledged:

Addendum No. _____ Addendum No. _____ Addendum No. _____
Addendum No. _____ Addendum No. _____ Addendum No. _____

The bidder proposes and agrees to contract with the Owner to perform all the above work, including subsidiary obligations as defined in said specifications for the prices indicated in Section 00310, **BID SCHEDULE**.

Further in submitting its bid, the undersigned Bidder understands and agrees that the Total Base Bid amount is determined by the sum total of all bid item amounts in the Bid Schedule. Bid Items include all work as defined in Section 01025, **MEASUREMENT AND PAYMENT**. No base bid items will be excluded from the awarded contract. Alternate bid items may be selected and included in the awarded contract. If award is made, it will be based on the lowest responsive, responsible bid whose Total Base Bid yields the lowest Contract Price. The previously listed alternate is only utilized for determination of the low bid. Such listing does not indicate that the Owner will select the listed alternate. Final selection of any or all alternates shall be at the sole discretion of the Owner. The Bid Alternate prices shall remain valid to the date of Notice to Proceed for incorporation into the Contract in the Agreement or as a change order.

Only one contract will be awarded.

The undersigned has filled in all information required herein and understands that failure to do so is grounds for rejecting the bid by the Owner.

The Owner reserves the right to change, delete or add new work to the Contract as per the terms of the General Conditions of the Contract Documents.

The undersigned has checked carefully all the above figures and understands that the Owner will not be responsible for any errors or omissions on the part of the undersigned in making up this proposal.

The undersigned understands that the Owner reserves the sole right to reject any or all bids and to waive any informality in bid. Award will be made which, in the judgment of the Owner, is in the best interest of the Owner.

It is agreed that this proposal may not be withdrawn within a period of sixty (60) calendar days after the date set for the opening thereof, except as allowed in Public Contract Code 5103.

Enclosed herewith is a (certified check, cashier's check, bond) for not less than ten (10) percent of the total amount of this proposal and the undersigned agrees that, in case of its default in executing the Contract, furnishing the necessary bonds and insurance policies within ten (10) days after notice of the award to the successful bidder, the said check or bond and the money payable thereon shall become and remain the property of the Owner, as liquidated damages without proof of loss within ten (10) days of notice of default by Owner. In the event bidder provides the Owner with a Proposal Guaranty Bond, it shall be on the form enclosed herewith in Section 00410, **BIDDER'S BOND** and be issued by a corporate surety. The corporate surety shall be authorized to conduct business in California. At its discretion, the Owner may request that a certified copy of the certificate of authority of the surety issued by the Insurance Commissioner of the State of California be submitted by the surety to the Owner. At its discretion, the Owner may also request the surety to provide copies of its most recent annual statement and quarterly statement filed with the Department of Insurance pursuant to Article 10 (commencing with Section 900) of Chapter 1 of Part 2 of Division 1 of the Insurance Code. The Bond and the corporate surety will be reviewed and approved by the Owner's counsel.

In accordance with the Specifications, the undersigned further agrees to so plan the work and to prosecute it with such diligence that said work shall be commenced within ten (10) days after the date of issuance of the notice to proceed and shall be completed within the time specified in Section 00800-1.1, **Time Allowed for Completion**.

The undersigned agrees, if awarded the Contract, that there shall be paid by the undersigned and by all subcontractors under him, to all laborers, workers and mechanics employed in the execution of such Contract or any subcontract thereunder, not less than the general prevailing rate of per diem wages, and rates for overtime and legal holidays in the locality in which the work is to be performed, as ascertained and determined, pursuant to California Labor Code Sections 1770, 1773, 1773.1, 1773.6, and 1773.7 as amended. The Director of the Department of Industrial Relations has determined the general prevailing rate of per diem wages in accordance with the standards set forth in Section 1773 for the locality in which the Work is to be performed. A copy of said wage rates is available on-line at www.dir.ca.gov/DLSR/PWD. It shall be mandatory upon the Contractor to whom the Work is awarded and upon any subcontractor under the Contractor to pay not less than said specified rates to all workers employed by them in the execution of the Work. Said prevailing

Name of Bidder

rate of per diem wages will be made available to any interested party upon request, and a copy thereof shall be posted at the job site by the Contractor. The representations made herein, including the bidder's licensing information hereinafter furnished, are made under penalty of perjury. The undersigned understands that any bid not containing said licensing information, or containing any information which is subsequently proven false, may be considered non-responsive, and be rejected by the Owner.

Signed

Name _____

Contractor

By _____

Title _____

Contr. License No. _____

License Classification

Expiration Date _____

Dated _____

Address _____

Telephone _____

CERTIFICATES. Shall be attached to the bid form and submitted with the bid.

- A. Bids by corporations must be executed in the corporate name by the president, a vice-president, or other corporate officer. Such Bid shall be accompanied by the enclosed Certificate of Authority to sign, attested by the secretary or assistant secretary. The corporate address and state of incorporation must appear below the signature.

- B. Bids by partnerships must be executed in the partnership name and be signed by a managing partner, accompanied by the enclosed Certificate of Authority to sign, and his/her title must appear under the signature and the official address of the partnership must appear below the signature.
- C. Bids by joint venture must be executed in the joint venture name and be signed by a joint venture managing partner, accompanied by the enclosed Certificate of Authority to sign, and his/her title must appear under the signature and the official address of the joint venture must appear below the signature. Additionally, the Bid shall bind the joint venture.
- D. If the Bid is made by an individual, bidder's name, signature, and post office address must be shown.

BID PROPOSAL CERTIFICATE
(if Corporation)

STATE OF CALIFORNIA)
) ss
COUNTY OF)

I HEREBY CERTIFY that a meeting of the Board of Directors of the _____

(Name of corporation and post office address),
a corporation existing under the laws of the State of _____, held on
_____, 20____, the following resolution was duly passed and adopted:

“RESOLVED, that _____, as _____
President of the Corporation, be and is hereby authorized to execute the Bid Proposal
dated _____, 20____, for the 2024 Sewer Rehabilitation Project -
Tiburon and Belvedere for Sanitary District No. 5, and that his/her execution thereof,
attested by the

(Secretary or title of Person who signs on behalf of the Corporation),
and with the Corporate Seal affixed, shall be the official act and deed of this
Corporation.”

I further certify that said resolution is now in full force and effect.

IN WITNESS WHEREOF, I have hereunto set my hand and affixed the official seal of the
corporation this _____, day of _____, 20 ____.

_____⁽¹⁾
(Title of Person who signs on behalf of Corporation)

(1) Include a certified copy of the bylaws or resolution of the Board of Directors of the
corporation showing authority of the officer signing the Bid to execute contracts on behalf of
the corporation.

BID PROPOSAL CERTIFICATE
(if Partnership)

STATE OF CALIFORNIA)
) ss
COUNTY OF)

I HEREBY CERTIFY that a meeting of the Partners of the _____
_____, a
partnership existing under the laws of the State of _____, held on
_____, 20____, the following resolution was duly passed and adopted:

“RESOLVED, that _____, as the
General Partner of the Partnership, be and is hereby authorized to execute the Bid
Proposal dated _____, 20____, for 2024 Sewer Rehabilitation Project -
Tiburon and Belvedere for the Sanitary District No. 5, and that his/her execution
thereof, attested by the _____, shall be the official act and deed of this
Partnership.”

I further certify that said resolution is now in full force and effect.

IN WITNESS WHEREOF, I have hereunto set my hand this _____, day of
_____, 20 ____.

Signature of General Partner

List all Partners

BID PROPOSAL CERTIFICATE
(if Joint Venture)

STATE OF CALIFORNIA)
) ss
COUNTY OF)

I HEREBY CERTIFY that a meeting of the Principals of the _____
_____ a
joint venture existing under the laws of the State of _____, held on
_____, 20____, the following resolution was duly passed and adopted:

“RESOLVED, that _____, as
_____ of the joint venture, be and is hereby authorized to execute
the Bid Proposal dated _____, 20____, for the 2024 Sewer Rehabilitation
Project - Tiburon and Belvedere for the Sanitary District No. 5, and that his/her
execution thereof, attested by the _____, shall be the official act and
deed of this Joint Venture and shall bind the Joint Venture.”

I further certify that said resolution is now in full force and effect.

IN WITNESS WHEREOF, I have hereunto set my hand this _____, day of
_____, 20 ____.

(Representative of one of the Joint Venture firms)

THIS PAGE INTENTIONALLY LEFT BLANK

BID SCHEDULE

BASE BID							
No	Tib Quant	Belv Quant	Quant	U/M	Item Description	Unit Price	BASE BID Total Amount
1	.5	.5	1	LS	MOBILIZATION, DEMOBILIZATION, AND SWPPP		
2				LF	PRE-CLEAN AND PRE-TELEWISE SEWER MAINS		
3.				LF	LINES A THRU K 6.63" OD HDPE SEWER MAIN - PIPEBURST		
4				EA	POTHOLE AND CONSTRUCT AIR GAP FOR PIPEBURSTING AT UTILITY MAIN CROSSING		
5				EA	INSTALL (N) STANDARD 4' DIAMETER MANHOLES		
6				EA	INSTALL (N) SHALLOW MANHOLES		
7				EA	REMOVE EXISTING MANHOLES		
8				EA	CONNECT TO EXISTING MANHOLES, REPLACE RIM AND COVER AND GRADE RINGS, REBUILD CHANNELS		
9				EA	REMOVE AND DISPOSE OF RODHOLES		
10				EA	LOCATE & POTHOLE EXISTING LATERALS		
11				EA	4" LATERAL CLEANOUTS AND CLEANOUT BOX		
12				LF	4" LATERAL, FITTINGS & CONNECTIONS – PIPEBURST		
13				LF	CURB AND GUTTER AND AC CURB REPLACEMENT		
14				SF	CONCRETE SIDEWALK AND DRIVEWAY APPROACH REPLACEMENT		
15				TON	ASPHALT CONCRETE TRENCH REPAIR AND REPLACEMENT OF PAVEMENT MARKINGS		
16	.5	.5	1	LS	SHORING FOR ALL EXCAVATIONS		

BASE BID (continued)							
No	Tib Quant	Belv Quant	Quant	U/M	Item Description	Unit Price	BASE BID Total Amount
17				EA	POTHOLE UTILITY MAINS WITHOUT AIR GAP		
18				LS	TRAFFIC CONTROL AND NOTIFICATIONS		
19	.5	.5	1	LS	PERMITS AND LICENSES		
20				LF	CLEANING AND TELEVISIONING OF COMPLETED SEWER MAINS		
21				LF	INTERNAL TELEVISIONING OF COMPLETED LOWER SEWER LATERALS		
TOTAL BASE BID			ITEMS 1 through 21 inclusive and all work connected thereto and connected therewith			\$ _____	

It is understood and mutually agreed that the quantities of work shown herein are approximate only and are subject to increase or decrease, and the undersigned offers to do the work, whether the quantities are increased or decreased, at the unit prices stated in this bid.

SECTION 00410

BIDDER'S BOND

We, _____, as Principal, and _____ as Surety, jointly and severally, bind ourselves, our heirs, representatives, successors and assigns, as set forth herein, to the Sanitary District No. 5 (herein called "the Owner") for the payment of the penal sum of _____ dollars (\$ _____), lawful money of the United States, which is ten percent (10%) of the total amount bid by bidder to the Owner. Principal has submitted the accompanying bid for the construction of the 2024 Sewer Rehabilitation Project - Tiburon and Belvedere.

If the Principal is awarded the contract and enters into a written contract, in the form prescribed by the Owner, at the price designated by his bid, and files the bonds required by the Agreement with the Owner, and carries all insurance in type and amount which conforms to the contract documents and furnishes required certificates and endorsements thereof, all within the times defined in the Contract Documents, then this obligation shall be null and void; otherwise it shall remain in full force and effect.

Forfeiture of this bond, or any deposit made in lieu thereof, shall not preclude the Owner from seeking all other remedies provided by law to cover losses sustained as a result of the Principal's failure to do any of the foregoing.

Principal and Surety agree that if the Owner is required to engage the services of an attorney in connection with the enforcement of this bond, each shall pay the Owner's reasonable attorney's fees, witness fees and other costs incurred with or without suit.

Executed on _____, _____.

PRINCIPAL

By _____
Signature

Title

Name of Bidder

Any claims under this bond may be addressed to:

(Name and address of Surety's agent for service of process in California, if different from above)

(Telephone number of Surety's agent in California)

(Attach Acknowledgment)

SURETY

By _____
(Attorney-in-Fact)

NOTICE:

No substitution or revision to this bond form will be accepted. Be sure that all bonds submitted have a certified copy of the bonding agent's power of attorney attached. Also verify that Surety is an "Admitted Surety" (i.e., qualified to do business in California), and attach proof of verification (website printout from the California Department of Insurance website <http://www.insurance.ca.gov/docs/index.html>) or certificate from County Clerk).

***** END OF SECTION *****

SECTION 00430

DESIGNATION OF SUBCONTRACTORS

(To Accompany Bid)

In accordance with California Public Contract Code, Section 4100 et. seq., as amended, the following is submitted concerning subcontractors: Each bidder shall set forth below (a) name and the location of the place of business of each subcontractor who will perform work or labor, fabricate a portion of the work or improvement according to detailed drawings in the project plans, or render service to the Contractor in or about the construction of the work in an amount in excess of one-half (1/2) of one percent (1%) of the Contractor's total bid or \$10,000 which ever is greater; and (b) the portion of the work (type and trade) which will be done by each such subcontractor. If a Contractor fails to specify a subcontractor or, if a contractor specifies more than one subcontractor for the same portion of work to be performed under the contract in excess of one-half (1/2) of one percent (1%) of the contractor's total bid for any portion of the work as above stated, the Contractor agrees that he/she is fully qualified to perform that portion himself/herself, and that the contractor shall perform that portion himself/herself. Subcontractors work for which no subcontractor was designated in the original bid and which is in excess of one-half (1/2) of one percent (1%) of the total contract price, will be allowed only with written consent of the Owner in accordance with applicable law. The Contractor shall provide to the Owner the license number of each listed subcontractor within ten (10) days of issuance of the Notice to Proceed.

<u>Name of Subcontractor</u>	<u>Contractor's License No.</u>	<u>Business Location</u>	<u>Description of Work To Be Performed (Type and Trade)</u>
_____	_____	_____	_____
_____	_____	_____	_____
_____	_____	_____	_____
_____	_____	_____	_____
_____	_____	_____	_____
_____	_____	_____	_____
_____	_____	_____	_____
_____	_____	_____	_____
_____	_____	_____	_____

SECTION 00440

**SITE VISIT AFFIDAVIT
TO BE EXECUTED
BY BIDDER, NOTARIZED AND SUBMITTED WITH BID**

(To Accompany Bid)

State of California)
County of) ss.

_____, **being first duly sworn**, deposes and says that he or
(Contractor's Authorized Representative)

she is

_____ of _____, the party making the foregoing
(Title of Representative) (Contractor's Name)

bid, has visited the Site of the Work as described in the Contract and has examined and familiarized themselves with the existing conditions, as well as all other conditions relating to the construction which will be performed. The submitting of a bid shall be considered an acknowledgement on the part of the Bidder of familiarity with conditions at the site of Work. The Bidder further acknowledges that the site examination has provided adequate and sufficient information related to existing conditions which may affect cost, progress or performance of the Work.

Signature

Name of Bidder

Title

Date

Attach a Certificate of Acknowledgement for the Notary to the Affidavit.

***** END OF SECTION *****

THIS PAGE INTENTIONALLY LEFT BLANK

SECTION 00450

**SCHEDULE OF
MAJOR EQUIPMENT AND MATERIAL SUPPLIERS,
PRODUCTS IDENTIFIED BY NAME AND SUBSTITUTION**

Bidders must designate the manufacturer/supplier of each item of equipment, materials or system included on the attached list. The Bidder shall name a manufacturer for each item and the supplier of the item if the supplier is not the manufacturer.

In accordance with California Public Contract Code Section 3400, where the project plans or specifications list products by manufacturer's name, brand or model number, such information indicates the quality and utility of the items desired and does not restrict bidders to that manufacturer's name, brand or model number, absent an express requirement that the listed product is only available from one source, or is necessary to match others in use on a particular public improvement either completed or in the course of completion. Except where expressly indicated in the plans, specifications, or this schedule that a particular brand product is only available from one source or is necessary to match others in use, when a manufacturer's name, brand or model number is listed, it shall be construed to be followed by the words "or equal" whether or not those words in fact follow the manufacturer's name, brand name or model number listed. Absent an express requirement that the listed product is only available from one source, or is necessary to match others in use on a particular public improvement either completed or in the course of completion, bidders may propose equals of products listed by manufacturer name, brand name or model number.

Complete information for products proposed as equals must be submitted to the Owner for review no later than 5:00 p.m. on the fifth day following the Bid opening by the low Bidder and by the second low Bidder if so requested by the Owner. To be considered, proposals concerning products proposed as equals must include sufficient information to permit the Owner to determine whether the products proposed as equals are in compliance with the requirements of the Contract Documents, and will satisfy the same performance requirements as products listed by manufacturer's name, brand or model number. Such performance requirements may include, but are not limited to, size, strength, function, and appearance, ease of maintenance and repair, and useful life requirements. Proposals concerning products proposed as equals that are submitted later than 5:00 p.m. on the fifth day following the bid opening may not be considered. Full submittal information as specified under Specification Section 01340, **SHOP DRAWINGS, PRODUCT DATA AND SAMPLES**, shall be submitted following award.

The Bidder shall be responsible for any additional costs necessary for the incorporation of such substitutions as provided for in Specification Section 01340-2.0, **MATERIAL AND EQUIPMENT SUBSTITUTIONS**.

Failure to bid products specified by manufacturer name, brand name or model number where the plans or specifications specify that a particular product is only available from one source or is necessary to match others in use, or to timely submit a proposal concerning products proposed as equals may render a bid non-responsive.

If the Owner should determine that a proposed "or equal" substitute does not meet the requirements of the Contract Documents, the Owner will provide written notice to the Bidder of such determination. Such notice will stipulate that the Bidder has five working days to provide written response as to which listed manufacturer/supplier it will provide or to submit

documentation for an acceptable “or equal” substitute in either case without change in the Bid price or alternatively to request to withdraw its Bid. If the Bidder fails to provide written response the Bidder will be required to provide the first listed manufacturer/supplier without change in the Bid price.

The following named items of major equipment and materials will be supplied by the manufacturers or suppliers as indicated by the Bidder, where no manufacturer or brand name is specified or as specified by the Owner. By so indicating, the Bidder warrants that the equipment and material manufactured and/or supplied by the named manufacturer or supplier will be provided on the project unless review of submittal information or performance under tests reveals that the equipment or material does not meet the Contract requirements.

If the Bidder fails to identify a manufacturer/supplier for any item shown on this list, the Owner has the right to waive such omission. In such case it will be assumed that the manufacturer/supplier to be used by the Bidder will be the first listed manufacturer/supplier identified for the given item under these Specifications without change in the contract price.

Equipment	Manufacturer

BIDDER

(Signature)

(Date)

***** END OF SECTION *****

SECTION 00458

CERTIFICATION OF DRUG-FREE WORKPLACE REQUIREMENTS

DRUG-FREE WORKPLACE CERTIFICATION

CONTRACTOR/APPLICANT: _____

The contractor or applicant named above hereby certifies compliance with Government Code Section 8355 in matters relating to providing a drug-free workplace. The above named contractor or applicant will:

1. Publish a statement notifying employees that unlawful manufacture, distribution, dispensation, possession, or use of a controlled substance is prohibited and specifying actions to be taken against employees for violations, as required by Government Code Section 8355(a).
2. Establish a Drug-Free Awareness Program as required by Government Code Section 8355(b), to inform employees about all of the following:
 - (a) The dangers of drug abuse in the workplace,
 - (b) The person's or organization's policy of maintaining a drug-free workplace,
 - (c) Any available counseling, rehabilitation and employee assistance programs, and
 - (d) Penalties that may be imposed upon employees for drug abuse violations.
3. Provide as required by Government Code Section 8355(c), that every employee who works on the proposed contract or loan:
 - (a) Will receive a copy of the company's drug-free policy statement, and
 - (b) Will agree to abide by the terms of the company's statement as a condition of employment on the contract or loan.

CERTIFICATION

I, the official named below, hereby swear that I am duly authorized legally to bind the contractor or loan recipient to the above described certification. I am fully aware that this certification, executed on the date and in the county below, is made under penalty of perjury under the laws of the State of California.

OFFICIAL'S NAME: _____

DATE EXECUTED: _____ EXECUTED IN COUNTY OF: _____

CONTRACTOR/APPLICANT SIGNATURE: _____

TITLE: _____

*****END OF SECTION*****

THIS PAGE INTENTIONALLY LEFT BLANK

SECTION 00460

**CERTIFICATION OF BIDDER'S
EXPERIENCE AND QUALIFICATIONS**

(To Accompany Bid)

The undersigned Bidder certifies that it is, at the time of bidding, and shall be, throughout the period of the contract, licensed under the provisions of Chapter 9, Division 3, of the Business and Professions Code of the State of California, to do the type of work contemplated in the Contract Documents. Bidder shall further certify that it is skilled and regularly engaged in the general class and type of work called for in the Contract Documents.

The Bidder represents that it is competent, knowledgeable, and has special skills on the nature, extent, and inherent conditions of the work to be performed. Bidder further acknowledges that there are certain peculiar and inherent conditions existent in the construction of the particular facilities which may create, during the construction program, unusual or peculiar unsafe conditions hazardous to persons and property. Bidder expressly acknowledges that it is aware of such peculiar risks and that it has the skill and experience to foresee and to adopt protective measures to adequately and safely perform the construction work with respect to such hazards.

A. ESSENTIAL REQUIREMENTS FOR QUALIFICATION

If the answer to any of questions 1 through 3 is "no", or if the answer to any of questions 4 through 7 is "yes", the Bidder will be disqualified from being awarded the Contract.

1. Bidder possesses a valid and current California Contractor's license for the project for which it intends to submit a bid.
 Yes No
2. Bidder will comply with and provide all insurance as defined in Section 00800-2.0, Liability and Insurance.
 Yes No
3. Bidder has current Workers' Compensation insurance policy as required by the Labor Code or is legally self-insured pursuant to Labor Code section 3700 et. seq.
 Yes No
4. Has your contractor's license been revoked at any time in the last five (5) years?
 Yes No
5. Has a surety firm completed a contract on your behalf, or paid for completion because your firm was default terminated by the project owner within the last five (5) years?
 Yes No

6. At the time of submitting this qualification form, is your firm ineligible to bid on or be awarded a public works contract, or perform as a subcontractor on a public works contract, pursuant to either Labor Code section 1777.1 or Labor Code section 1777.7.
 Yes No
7. At any time during the last five (5) years, has your firm, or any of its owners or Officers been convicted of a crime involving the awarding of a contract of a government construction project, or the bidding or performance of a government contract?
 Yes No

B. PROJECT EXPERIENCE

The Bidder shall list below at least three (3) sewer projects or other industrial projects of reasonably similar nature completed in the last seven (7) years of similar size and complexity that indicate the Bidder's experience as a Contractor. If the Bid is submitted by a Joint Venture, list at least four (4) completed projects. It is acceptable to submit this information on other forms as long as the information required below is included. Failure to provide this information with the Bid may render the Bid non-responsive and may be the basis for rejection of the Bid.

1. **Project Name:** _____
Owner: _____
Construction Cost: \$ _____
Construction Time: _____ **Calendar Days**
Owner's Representative: _____
Owner's Telephone No.: _____
Date of Substantial Completion: _____
2. **Project Name:** _____
Owner: _____
Construction Cost: \$ _____
Construction Time: _____ **Calendar Days**
Owner's Representative: _____
Owner's Telephone No.: _____
Date of Substantial Completion: _____

3. **Project Name:** _____
Owner: _____
Construction Cost: \$ _____
Construction Time: _____ **Calendar Days**
Owner's Representative: _____
Owner's Telephone No.: _____
Date of Substantial Completion: _____

4. **Project Name:** _____
Owner: _____
Construction Cost: \$ _____
Construction Time: _____ **Calendar Days**
Owner's Representative: _____
Owner's Telephone No.: _____
Date of Substantial Completion: _____

5. **Project Name:** _____
Owner: _____
Construction Cost: \$ _____
Construction Time: _____ **Calendar Days**
Owner's Representative: _____
Owner's Telephone No.: _____
Date of Substantial Completion: _____

C. SAFETY QUALIFICATION CRITERIA

The following information will be used to determine if you meet the minimum safety requirements for this project. To qualify to bid and be awarded the project, the Contractor shall have a safety record that meets or exceeds one of the following safety criteria:

1. If the Contractor's three-year average Workers' Compensation Experience Modification (EMR) is equal to or less than 100%, the contractor meets the minimum safety requirements for this project;
2. If the Contractor's three-year average EMR is greater than 100%, the Contractor's three-year average Recordable Incident Rate (RIR) must not be greater than 5.5 and three-year average Lost Time Incident Rate (LTIR) must not be greater than 2.0 to meet the minimum safety requirements for this project;
3. If the Contractor only meets either the three-year average RIR or LTIR value, the Contractor shall be required to hire at no additional cost to the District a mutually acceptable safety consultant who will prepare a project specific safety plan, conduct random weekly inspections of the Contractor's activities to ensure conformance with the safety plan and prepare and submit a weekly report to the District summarizing the results of each inspection. The contractor's shall adhere to the safety plan. The contractor's activities shall be adjusted immediately to address any issues resulting from the weekly safety inspection.

Contractors that cannot meet any of the three safety criteria above are not eligible to work for the District.

The Bidder shall list its Experience Modification Rate, Lost time Incident Rate, and Recordable Incident Rate for the last three complete years (available from your insurance carrier).

<u>Year</u>	<u>EMR</u>
_____	_____
_____	_____
_____	_____
	_____AVG

<u>Year</u>	<u>RIR</u>	<u>LTIR</u>
_____	_____	_____
_____	_____	_____
_____	_____	_____
	_____AVG	_____AVG

To verify the above information, the Owner will contact the Bidder's Workers' Compensation Insurance carrier. The Bidder shall authorize its carrier to release this information. Failure to release this information will result in the bid being non-responsive and result in automatic disqualification of the bid.

Name of Bidder

Workers' Compensation Insurance Company: _____

Contact Person for Insurance Company: _____

Telephone Number: _____

Signed this _____ day of _____, 20 ____.

Name of Bidder

Contractor's License No.

Expiration Date

Signature of Bidder

Title of Signatory

D. FINANCIAL QUALIFICATIONS

Within two (2) working days after the bid opening date for this project, the three apparent lowest bidders shall submit a credit report, current within 30 days of the bid opening date for this project. For privacy purposes, the report may be submitted in an envelope marked "CONFIDENTIAL". To be considered a responsible bidder on this project, either the Contractor's credit report shall indicate a Dun & Bradstreet credit risk rating of 3A2 or better, **or** the Contractor's bank shall issue a financial statement on the following page. If the Contractor is a Dun & Bradstreet member, a copy of the current Dun & Bradstreet rating form showing a rating not less than 3A2 will suffice.

If the Contractor is not a Dun & Bradstreet member, an acceptable credit report shall consist of the submittal of the District's Financial Statement Form (which follows) executed by the Contractor's bank. Failure to submit the required report within two (2) working days of the bid opening date for this project shall cause the bid to be rejected. Failure to possess the required financial strength and credit risk rating shall cause the bid to be rejected. The District shall request confirmation of the Contractor's rating from Dun & Bradstreet Information Services. The sufficiency of the Bidder's financial qualifications will be determined solely by the District and its decision shall be final.

Reference is hereby made to the following bank or banks as to the financial responsibility of the Bidder:

<u>Name of Bank</u>	<u>Address</u>
_____	_____
_____	_____
_____	_____

Reference is hereby made to the following surety companies as to the financial responsibility and general reliability of the Bidder:

Name of Surety Company _____

Signature of Bidder Title

Company

Address

Name of Bidder

_____ has an established deposit
(Contractor)

And borrowing relationship with _____
(Bank)

since _____.
(Date)

Both business account and credit accommodations are maintained in a highly satisfactory manner. Based on my knowledge of _____'s
(Contractor)

Average monthly business account balances and its credit worthiness, I believe its general financial strength and credit rating meet or exceed the Dun & Bradstreet alphanumeric rating of not less than 3A2.

Contractor Company Name

Contractor Representative, Printed Name

Contractor Representative, Signature

Date

Bank Name

Bank Street Address

Bank City, State, Zip Code

Bank Representative, Printed Name

Bank Representative, Signature

Date

Following are two Dun & Bradstreet rating component sheets to assist in the evaluation of the responsible Bidder's tangible net worth and credit worthiness.

Dun & Bradstreet Rating Key

Quickly assesses a company’s size and composite credit appraisal, e.g., a company rated 3A3 has a worth of \$1,000,000 - \$9,999,999 based on an interim or fiscal balance sheet and a composite credit appraisal of ‘Fair’.

Key to Employee Range

ER1	1,000 or more
ER2	500-999
ER3	100-499
ER4	50-99
ER5	20-49
ER6	10-19
ER7	5-9
ER8	1-4
ERN	Not Available

Rating Classification

Composite Credit Appraisal

Based on Worth from Interim or Fiscal Balance Sheet

HIGH GOOD FAIR LIMITED

5A	\$50,000,000	and over		1	2	3	4
4A	10,000,000	to	\$49,999,999	1	2	3	4
3A	1,000,000	to	9,999,999	1	2	3	4
2A	750,000	to	999,999	1	2	3	4
1A	500,000	to	749,999	1	2	3	4
BA	300,000	to	499,999	1	2	3	4
BB	200,000	to	299,999	1	2	3	4
CB	125,000	to	199,999	1	2	3	4
CC	75,000	to	124,999	1	2	3	4
DC	50,000	to	74,999	1	2	3	4
DD	35,000	to	49,999	1	2	3	4
EE	20,000	to	34,999	1	2	3	4
FF	10,000	to	19,999	1	2	3	4
GG	5,000	to	9,999	1	2	3	4
HH		up to	4,999	1	2	3	4

Rating Classification

Composite Credit Appraisal

Based on Number of Employees

GOOD FAIR LIMITED

1R	10 employees and over		2	3	4
2R	1 to 9 employees		2	3	4

What The Ratings Mean

5A to HH

5A to HH ratings reflect company size based on worth or equity as computed by Dun & Bradstreet. Company size can be an effective indicator of credit capacity. These ratings are assigned to businesses that have supplied Dun & Bradstreet with a current financial statement.

1R and 2R

1R and 2R rating categories reflect company size based on the total number of employees for the business. They are assigned to business files that do not contain a current financial statement.

Composite Credit Appraisal

The Composite Credit Appraisal is a number, one through four, that makes up the second half of the company's rating and reflects Dun & Bradstreet's overall assessment of that firm's credit worthiness. The Composite Credit Appraisal is based on analysis by Dun & Bradstreet of company payments, financial information, public records, business age and other important factors (where available).

A '2' is the highest Composite Credit Appraisal a company not supplying Dun & Bradstreet with current financial information can receive.

Rating

May also include the '—' symbol, or absence of a Dun & Bradstreet rating. This symbol should not be interpreted as indicating that credit should be denied. It means that the information available to Dun & Bradstreet does not permit us to classify the company within our rating key and that further inquiry should be made before reaching a credit decision. Some reasons for using the '—' symbol include: deficit net worth, bankruptcy proceedings, lack of sufficient payment information or incomplete history indicator.

Date Applied

Allows you to review a company's rating changes over time (the last 10 rating changes or any changes since 1991 if less than 10 are provided).

ER (Employee Range)

Certain lines of business do not lend themselves to classification under the Dun & Bradstreet rating system. Instead, we assign these types of businesses an Employee Range symbol based on the number of people employed. No other significance should be attached to this symbol. For example, a rating of 'ER7' means there are between five and nine employees in the company. 'ERN' should not be interpreted negatively. It simply means we do not have information indicating how many people are employed at this firm.

DS (DUNS Support)

This indicates that the information available to Dun & Bradstreet does not permit us to classify the company within our rating key. When ordering these reports an investigation can be performed and results sent to you within four business days, at no additional charge.

INV (Investigation Being Conducted)

When an 'INV' appears, it means an investigation is being conducted on this business to get the most current details.

*****END OF SECTION*****

SECTION 00480

BIDDER'S AFFIDAVIT OF NON-COLLUSION SUBMITTED WITH BID

(To Accompany Bid)

_____, (Contractor) hereby declares that:

He or she is _____ (Title/Position) of _____

_____, (Company Name) the party making the foregoing bid; that the bid is not made in the interest of, or on behalf of, any undisclosed person, partnership, company, association, organization, or corporation; that the bid is genuine and not collusive or sham; that the bidder has not directly or indirectly induced or solicited any other bidder to put in a false or sham bid, and has not directly or indirectly colluded, conspired, connived, or agreed with any bidder or anyone else to put in a sham bid, or that anyone shall refrain from bidding; that the bidder has not in any manner, directly or indirectly, sought by agreement, communication, or conference with anyone to fix the bid price of the bidder or any other bidder, or to fix any overhead, profit, or cost element of the bid price, or of that of any other bidder, or to secure any advantage against the public body awarding the contract or anyone interested in the proposed contract; that all statements contained in the bid are true; and, further, that the bidder has not, directly or indirectly, submitted his or her bid price or any breakdown thereof, or the contents thereof, or divulged information or data relative thereto, or paid, any will not pay, any fee to any corporation, partnership, company, association, organization, bid depository, or to any member of agent thereof to effectuate a collusive or sham bid.

I declare under penalty of perjury under the laws of the State of California that the foregoing is true and correct.

Dated: _____
Signature _____

Subscribed and sworn to before me this
_____ day of _____, 20_____

Notary Public in and for the State of California

Public Contract Code Section 7106
Code of Civil Procedure Section 2015.5

***** END OF SECTION *****

THIS PAGE INTENTIONALLY LEFT BLANK

SECTION 00490

AFFIDAVIT OF SAFETY COMPLIANCE

The Contractor agrees in accordance with the requirements of Section 00700 - 4.7.1, General Conditions, that for purposes of California Labor Code Section 6400 and related provisions of law the Contractor, the Contractor's privities and any other entities acting pursuant to this contract will be "employers" responsible for furnishing employment and a place of employment that is safe and healthful for the employees, if any, of such entities acting pursuant to this contract and that the Owner will not be responsible for having hazards corrected and /or removed at the location where the work under the contract is to be performed.

The Contractor hereby acknowledges Owner concerns regarding safety at its facility and at the Project worksite. The Contractor shall conduct its operations to eliminate or reduce hazards and risks associated with Contractor's activities, to prevent accidents and injuries, and to prevent property damages. Therefore, strict compliance with all of the most current safety, health and environmental regulations (federal, state and local) is required. Non-compliance with these regulations may result in suspension or termination of work in progress.

The Contractor's Safety Programs must accomplish the foregoing objectives. The Contractor certifies that its Safety Programs comply and will satisfy these requirements. The Contractor also certifies that each Subcontractor and Sub-subcontractors and other parties with which it has agreements to perform work on the Project worksite will also comply and will satisfy these requirements.

The Contractor Safety Programs are listed in Part A of this section. The Contractor further certifies that it can furnish mandatory satisfactory evidence of compliance.

The Contractor acknowledges that it understands and will comply with all safety considerations applicable to this Project.

The Contractor further acknowledges that its Subcontractors and Sub-subcontractors will provide all Safety Compliance documents to Contractor in accordance with Specification Section 00490.

Executed On: _____, _____

Signature

Name of Bidder

Title

Attach a Certificate of Acknowledgement for the Notary to the Affidavit.

CERTIFICATE OF ACKNOWLEDGMENT

State of California)

)

County of _____)

On _____ Before me, _____,

DATE

NAME, NOTARY PUBLIC

personally appeared _____,

NAME, TITLE OF OFFICER

personally known to me - OR - ___ proved to me on the basis of satisfactory evidence to be the person(s) whose name(s) is/are subscribed to within the instrument and acknowledged to me that he/she/they executed the same in his/her/their authorized capacity(ies), and that by his/her/their signature(s) on the instrument the person(s), or the entity upon behalf of which the person(s) acted, executed the instrument.

Witness my hand and official seal.

Signature of Notary

PART A - Safety Programs

Please indicate below whether your firm has the following written safety programs. If any of the programs listed do not apply to your operations or this project, please make note of this in the “Comments” column. Include any information that you think would be helpful to us in making this assessment. Those programs that are indicated as mandatory must be available for review before commencing work on this project. Other safety programs may be requested if it is later determined that they are applicable to the Project, and as such, must be made available for review upon request, at no additional charge to the Owner.

Program		Do you have a written program?		Program meets Cal/OSHA Criteria		Sub will provide	Have project employees been trained?		Is the training documented?		Comments
		Yes	No	Yes	No		Yes	No	Yes	No	
Mandatory											
YES	Injury and Illness Prevention										
YES	Hazard Communication										
YES	Confined Space Operations										
	Respiratory Protection										
	Emergency Response										
	Hearing Conservation										
YES	Lockout/Tagout										
YES	New Employee Orientation										
YES	Excavation Safety										
	Code of Safe Practices										
YES	Personal Protective Equipment (PPE)										
YES	Drugs/Alcohol										
YES	Traffic Control Safety										
YES	Fall Prevention Plan ⁽¹⁾										

¹ If conventional fall protection measures cannot be used.

PART B - Safety Equipment - Identify what safety equipment will be available and used for this project.

Type	Description/Comments
<input type="checkbox"/> Gas detectors	
<input type="checkbox"/> Ventilation equipment	
<input type="checkbox"/> Approved harnesses and lanyards	
<input type="checkbox"/> Mechanical hoists	
<input type="checkbox"/> Fire extinguishers	
<input type="checkbox"/> First aid kits	
<input type="checkbox"/> Respirators	
<input type="checkbox"/> Hard hats	
<input type="checkbox"/> Hearing protectors	
<input type="checkbox"/> Safety goggles	
<input type="checkbox"/> Steel toed footwear	
<input type="checkbox"/> Hand protection	
<input type="checkbox"/> Fall protection	
<input type="checkbox"/> Confined Space Rescue Equipment	
<input type="checkbox"/>	

PART C - Specialized Training and Certification - Identify the areas of specialized training or certification that will have been completed by employees who will be assigned to this project. Be prepared to provide documentation as requested.

<input type="checkbox"/> CPR/first aid	<input type="checkbox"/> Confined space operations and rescue	<input type="checkbox"/> Scaffolding
<input type="checkbox"/> Fork lift operation	<input type="checkbox"/> Respirators <input type="checkbox"/> Air-Supplying <input type="checkbox"/> Air-Purifying	<input type="checkbox"/> Flagging
<input type="checkbox"/> Cranes/hoists operation	<input type="checkbox"/> Trenching and shoring competent person	<input type="checkbox"/> Traffic Control
<input type="checkbox"/> Heavy equipment operation	<input type="checkbox"/> Welding	<input type="checkbox"/>
<input type="checkbox"/> Powder-actuated tools use	<input type="checkbox"/> Asbestos abatement	<input type="checkbox"/>

Name of Bidder: _____

PART D - Jobsite Safety Practices

1. Name of person who will have responsibility for jobsite safety?

2. Who will be responsible for conducting and documenting accident investigations?

Does your company perform near-miss investigations? _____
Please provide sample copy of investigation forms.

3. How often are jobsite safety audits or inspections performed, _____
and by whom? _____

4. Does the person who is responsible for jobsite safety have authority to take immediate action to correct unsafe conditions of work practices? _____

5. How often are jobsite tailgate or toolbox safety meetings held? _____

6. Briefly describe how you will ensure that workers comply with safety programs and Cal/OSHA requirements? _____

7. Please list any Cal/OSHA citations and penalties you have received in the last three years.

8. Have there been any on-the-job fatalities at any job site managed by the Contractor in the last five years? _____ If yes, please explain.

9. Does your company have a safety incentive program? _____
If yes, please explain. _____

Name of Bidder: _____

PART E: Evaluation Worksheet

(FOR USE BY THE OWNER ONLY)

Company Name _____

Contact Person _____

Item	Program is Mandatory	Contractor has Written Program	Contractor States Program meets Cal/OSHA Criteria	Comments
PART A: Safety Programs				
Injury and Illness Protection	Yes			
Hazard Communication	Yes			
Confined Space Operations	Yes			
Lockout /Tagout	Yes			
New Employee Orientation	Yes			
Drug and Alcohol Policy	Yes			
Excavation Safety	Yes			
Traffic Control	Yes			
Other Programs: PPE, Fall Protection				
PART B: Safety Equipment				
PART C: Training and Certifications				
PART D: Jobsite Safety Practices				
Responsible Person Named				
Accident Investigations				
Worksite Safety Inspections				
Safety Meetings				
Compliance With Safety Requirements				
Cal/OSHA Citations/Penalties				
Fatalities				
Safety Incentives				

*** END OF SECTION***

SECTION 00500

AGREEMENT FOR THE CONSTRUCTION OF

2024 Sewer Rehabilitation Project
Tiburon and Belvedere

THIS AGREEMENT, made and concluded, in duplicate, this ____ day of _____, 20____, between the SANITARY DISTRICT NO. 5 ("Owner"), a public entity in Marin County, and _____ ("Contractor"), License No. _____.

The Owner and Contractor, in consideration of the mutual covenants hereinafter set forth, agree as follows:

WITNESSETH:

1. That for and in consideration of the payments and agreements hereinafter mentioned, to be made and performed by the Owner, and under the conditions expressed in the two bonds, bearing even date with these presents, and hereunto annexed, the Contractor agrees with the Owner, at his/her own proper cost and expense, to do all the work and furnish all the materials necessary to construct and complete in good workmanlike and substantial manner the project entitled: **2024 Sewer Rehabilitation Project - Tiburon and Belvedere** in strict conformity with the plans and specifications prepared therefor, which said plans and specifications are hereby specially referred to and by said reference made a part hereof.
2. Now, therefore, in consideration of the mutual covenants and agreements of the parties herein contained and to be performed, the Contractor hereby agrees to complete the work in accordance with the terms and conditions stipulated in the Contract Documents for the sum of _____
(\$ _____) computed in accordance with Contractor's accepted proposal dated _____, 20____, which accepted proposal is incorporated herein by reference thereto as if herein fully set forth. Compensation shall be based upon any lump sum bid items plus the unit prices stated in the Bid Schedule times the actual quantities or units of work and materials performed or furnished. The further terms, conditions, and covenants of this Agreement are set forth in the Contract Documents, each of which is by this reference made a part hereof. Payments are to be made to the Contractor in accordance with the provisions of the Contract Documents and the Technical Specifications in legally executed and regularly issued warrants of the Owner, drawn on the appropriate fund or funds as required by law and order of the Owner thereof.
3. The Owner hereby promises and agrees with the said Contractor to employ, and does hereby employ, the said Contractor to provide the materials and to do the work according to the terms and conditions herein contained and referred to, for the prices aforesaid, and hereby contracts to pay the same at the time, in the manner and upon the conditions above set forth; and the said parties for themselves, their heirs, executors, administrators, successors and assigns, do hereby agree to the full performance of the covenants herein contained.
4. The Contractor and any subcontractor performing or contracting any work shall comply

with all applicable provisions of the California Labor Code for all workers, laborers and mechanics of all crafts, classifications or types, including, but necessarily limited to the following:

(a) In accordance with California Labor Code Section 1810, eight (8) hours of labor in performance of the Work shall constitute a legal day's work under this Agreement. Contractor and any subcontractor shall pay workers overtime pay (not less than 1 1/2 times the base rate of pay) as required by California Labor Code Section 1815. Contractor and any subcontractor shall, as a penalty to the City, forfeit twenty-five dollars (\$25) for each worker employed in the execution of the contract by the respective contractor or subcontractor for each calendar day during which the worker is required or permitted to work more than 8 hours in any one calendar day and 40 hours in any one calendar week in violation so the provisions of Article 3 of Chapter 1 of Part 7, Division 2 of the California Labor Code, which is incorporated by this reference as though fully set forth herein.

(b) Pursuant to the provisions of California Labor Code, Sections 1770 et. seq., the Contractor and any subcontractor under him shall pay not less than the prevailing rate of per diem wages as determined by the Director of the California Department of Industrial Relations. Pursuant to the provisions of California Labor Code Section 1773.2, the Contractor is hereby advised that copies of the prevailing rate of per diem wages and a general prevailing rate for holidays, Saturdays and Sundays and overtime work in the locality in which the work is to be performed for each craft, classification, or type of worker required to execute the Contract, are on file in the office of the District Secretary, which copies shall be made available to any interested party on request. The Contractor shall post a copy of said prevailing rate of per diem wages at each job site.

(c) As required by Section 1773.1 of the California Labor Code, the Contractor shall pay travel and subsistence payments to each worker needed to execute the work, as such travel and subsistence payments are defined in the applicable collective bargaining agreements filed in accordance with this Section.

(d) To establish such travel and subsistence payments, the representative of any craft, classification, or type of workman needed to execute the contracts shall file with the Department of Industrial Relations fully executed copies of collective bargaining agreements for the particular craft, classification or type of work involved. Such agreements shall be filed within ten (10) days after their execution and thereafter shall establish such travel and subsistence payments whenever filed thirty (30) days prior to the call for bids.

(e) The Contractor shall comply with the provisions of Section 1775 of the California Labor Code and shall, as a penalty to the Owner, forfeit up to fifty dollars (\$50) for each calendar day, or portion thereof, for each worker paid less than the prevailing rate of per diem wages for each craft, classification, or type of worker needed to execute the contract. The Contractor shall pay each worker an amount equal to the difference between the prevailing wage rates and the amount paid worker for each calendar day or portion thereof for which a worker was paid less than the prevailing wage rate. Contractor is required to pay all applicable penalties and back wages in the event of violation of prevailing wage law, and Contractor and any subcontractor shall fully comply

with California Labor Code Section 1775, which is incorporated by this reference as though fully set forth herein.

(f) Contractor and any subcontractor shall maintain and make available for inspection payroll records as required by California Labor Code Section 1776, which is incorporated by this reference as though fully set forth herein. Contractor is responsible for ensuring compliance with this section. Contractor and each subcontractor shall keep an accurate payroll record, showing the name, address, social security number, work classification, and straight time and overtime hours worked each day and week, and the actual per diem wages paid to each journeyman, apprentice, worker, or other employee employed by him or her in connection with the Sanitary District No. 5, **2024 Sewer Rehabilitation Project - Tiburon and Belvedere**. Said payroll shall be certified and shall be available for inspection at all reasonable hours at the principal office of the Contractor on the following basis:

(1) A certified copy of an employee's payroll record shall be made available for inspection or furnished to the employee or his or her authorized representative on request.

(2) A certified copy of all payroll records enumerated in Paragraph 4(f), herein, shall be made available for inspection or furnished upon request to the District, the Division of Labor Standards Enforcement, and the Division of Apprenticeship Standards of the Department of Industrial Relations.

(3) A certified copy of all payroll records enumerated in Paragraph 4(f), herein, shall be made available upon request by the public for inspection or for copies thereof; provided, however, that a request by the public shall be made through either the Owner, the Division of Apprenticeship Standards, or the Division of Labor Standards Enforcement. If the requested payroll records have not been provided pursuant to subparagraph 4(f)(2) herein, the requesting party shall, prior to being provided the records, reimburse the costs of preparation by the Contractor, subcontractors, and the entity through which the request was made. The public shall not be given access to the records at the principal offices of the Contractor.

The certified payroll records shall be on forms provided by the Division of Labor Standards Enforcement or shall contain the same information as the forms provided by the division.

Each Contractor shall file a certified copy of the records, enumerated in Paragraph 4(f) with the entity that requested the records within ten (10) days after receipt of a written request. Any copy of records made available for inspection as copies and furnished upon request to the public or any public agency by the Owner, the Division of Apprenticeship Standards, or the Division of Labor Standards Enforcement shall be marked or obliterated in such a manner as to prevent disclosure of an individual's name, address, and social security number. The name and address of the Contractor awarded the contract or performing the contract shall not be marked or obliterated. The Contractor shall inform the Owner of the location of the records enumerated under Paragraph 4(f) including the street address, city and county, and shall,

within 5 working days, provide a notice of change of location and address. The Contractor shall have ten (10) days in which to comply subsequent to receipt of written notice specifying in what respects the Contractor must comply with this Paragraph 4(f). In the event that the Contractor fails to comply within the 10-day period, he or she shall, as a penalty to the state or the Owner, forfeit \$25.00 dollars for each calendar day, or portion thereof, for each worker, until strict compliance is effectuated. Upon the request of the Division of Apprenticeship Standards or the Division of Labor Standards Enforcement, these penalties shall be withheld from progress payments then due. Responsibility for compliance with Paragraph 4(f) lies with the Contractor.

(g) The Contractor and any subcontractors shall, when they employ any person in any apprenticeable craft or trade, apply to the joint apprenticeship committee administering the apprenticeship standards of the craft or trade in the area of the construction site for a certificate approving the Contractor or subcontractor under the apprenticeship standards for the employment and training of apprentices in the area or industry affected; and shall comply with all other requirements of Section 1777.5 of the California Labor Code, which is incorporated by this reference as though fully set forth herein. The responsibility of compliance with California Labor Code Section 1777.5 during the performance of this contract rests with the Contractor. Pursuant to California Labor Code Section 1777.7, in the event the Contractor willfully fails to comply with the provisions of California Labor Code Section 1777.5, the Contractor shall be denied the right to bid on any public works contract for up to three (3) years from the date noncompliance is determined and be assessed civil penalties.

(h) In accordance with the provisions of Article 5, Chapter 1, Part 7, Division 2 (commencing with Section 1860), and Chapter 4, Part 1, Division 4 (commencing with Section 3700) of the California Labor Code, the Contractor is required to secure the payment of compensation to its employees and for that purpose obtain and keep in effect adequate Workers' Compensation Insurance and Employers Liability Insurance. If the Contractor, in the sole discretion of the Owner satisfies the Owner of the responsibility and capacity under the applicable Workers' Compensation Laws, if any, to act as self-insurer, the Contractor may so act, and in such case, the insurance required by this paragraph need not be provided.

The Contractor is advised of the provisions of Section 3700 of the California Labor Code, which requires every employer to be insured against liability for Workers' Compensation or to undertake self-insurance in accordance with the provisions of that Code and shall comply with such provisions and have Employer's General Liability limits of \$1,000,000 per accident before commencing the performance of the work of this Contract.

The Notice to Proceed with the Work under this Contract will not be issued, and the Contractor shall not commence work, until the Contractor submits written evidence that it has obtained full Workers' Compensation Insurance coverage for all persons whom it employs or may employ in carrying out the work under this Contract. This insurance shall be in accordance with the requirements of the most current and applicable state Workers' Compensation Insurance Laws. In accordance with the provisions of Section 1861 of the California Labor Code, the Contractor in signing this agreement certifies to the Owner as true the following statement: "I am aware of the provisions of Section 3700 of the Labor Code which requires every employer to be insured against liability for

Workers' Compensation or to undertake self-insurance in accordance with the provisions of that Code, and I will comply with such provisions before commencing the performance of the work of this contract."

A subcontractor is not allowed to commence work on the project until verification of Workers' Compensation Insurance coverage has been obtained and verified by the Contractor and submitted to the Construction Manager for the Owner's review and records.

(i) In accordance with the provisions of Section 1727 of the California Labor Code, the Owner, before making payment to the Contractor of money due under a contract for public works, shall withhold and retain therefrom all wages and penalties which have been forfeited pursuant to any stipulation in the contract, and the terms of Chapter 1, Part 7, Division 2 of the California Labor Code (commencing with Section 1720). But no sum shall be withheld, retained or forfeited, except from the final payment, without a full investigation by either the Division of Labor Standards Enforcement or by the Owner.

5. It is further expressly agreed by and between the parties hereto that should there be any conflict between the terms of this Agreement the instrument and the bid proposal of said Contractor, then this Agreement instrument shall control, and nothing herein contained shall be considered as an acceptance of the said terms of said proposal conflicting herewith.

6. The Contractor agrees to provide and maintain insurance coverage, and to indemnify and save harmless the parties named and in the manner set forth in Section 00800-2.0, **LIABILITY AND INSURANCE**, of the Supplementary General Conditions of the Specifications.

The duty of Contractor to indemnify and save harmless, as set forth herein, shall include a duty to defend as set forth in Section 2778 of the California Civil Code; provided, however, that nothing herein shall be construed to require Contractor to indemnify against any responsibility or liability in contravention of Section 2782 of the California Civil Code.

7. The Contractor shall diligently prosecute the work so that it shall be substantially completed within the time specified in Section 00800-1.1, **Time Allowed for Completion**.

8. Except as otherwise may be provided herein, Contractor hereby expressly guarantees for one (1) full year from the date of acceptance of the Work under this agreement thereof by the Owner, to repair or replace any part of the work performed hereunder which constitutes a defect resulting from the use of inferior or defective materials, equipment or workmanship. If, within said period, any repairs or replacements in connection with the work are, in the opinion of the Owner, rendered necessary as the result of the use of inferior or defective materials, equipment or workmanship, Contractor agrees, upon receipt of notice from Owner, and without expense to Owner, to promptly repair or replace such material or workmanship and/or correct any and all defects therein. If Contractor, after such notice, fails to proceed promptly to comply with the terms of this guarantee, Owner may perform the work necessary to effectuate such correction and recover the cost thereof from the Contractor and/or its sureties.

In special circumstances where a particular item of work or equipment is placed in continuous service before completion of all the Work, the correction period for that item may start to run from an earlier date. This date shall be agreed upon in writing by the Contractor and Owner on or before the item is placed in continuous service.

Any and all other special guarantees which may be applicable to definite parts of the work under this agreement shall be considered as an additional guarantee and shall not reduce or limit the

guarantee as provided by Contractor pursuant to this paragraph during the first year of the life of such guarantee.

9. The Contractor shall provide, on the execution of this Agreement, a good and sufficient corporate surety bond in the penal sum of one hundred percent (100%) of amount bid as stipulated in the General Conditions, Section 00700-1.8, Bond, which bond shall be on the forms provided by the Owner in Section 00610, **(FAITHFUL PERFORMANCE BOND)**, and be conditioned upon the faithful performance of all work and payment of all the Contractor's obligation under the Contract Documents. Said bond shall be liable for any and all penalties and obligations which may be incurred by Contractor under this Agreement. The corporate surety bond shall be issued by a corporate surety approved by the Owner. The corporate surety shall be authorized to conduct business in California. At its discretion, the Owner may request that a certified copy of the certificate of authority of the insurer issued by the Insurance Commissioner of the State of California be submitted by the surety to the Owner. At its discretion, the Owner may also require the insurer to provide copies of its most recent annual statement and quarterly statement filed with the Department of Insurance pursuant to Article 10 (commencing with Section 900) of Chapter 1 of Part 2 of Division 1 of the Insurance Code. This bond shall remain in effect at least until one year after the Date of Completion, except as otherwise provided by Law or Regulation or by the Contract Documents.

10. In addition to the bond required under Paragraph 9, hereof, Contractor shall furnish a good and sufficient corporate surety bond in the penal sum of one hundred percent (100%) of amount of bid, which bond shall be on the form provided by the Owner in Section 00620, **(PAYMENT BOND)**, and conform strictly with the provisions of Chapter 7, Title 15, Part 4, Division 3, of the Civil Code of the State of California, and all amendments thereto. The corporate surety bond shall be issued by a corporate surety approved by the Owner. The corporate surety shall be authorized to conduct business in California. At its discretion, the Owner may request that a certified copy of the certificate of authority of the insurer issued by the Insurance Commissioner of the State of California be submitted by the surety to the Owner. At its discretion, the Owner may also require the insurer to provide copies of its most recent annual statement and quarterly statement filed with the Department of Insurance pursuant to Article 10 (commencing with Section 900) of Chapter 1 of Part 2 of Division 1 of the Insurance Code.

11. (a) The form of the Faithful Performance (Section 00610), and Payment Bond (Section 00620), Bonds are provided by the Owner as part of the Contract Documents. Only such bond forms provided by the Owner are acceptable and, to the extent required by project funding sources, shall be executed by corporate sureties who are admitted surety insurers in the state of California in accordance with applicable law and acceptable to the Owner. All Bonds signed by an agent must be accompanied by a certified copy of such agent's authority to act.

(b) If the surety on any Bond furnished by the Contractor is declared bankrupt or becomes insolvent or its right to do business is terminated in any state where any part of the Work is located, the Contractor shall within 7 days thereafter substitute another Bond and surety, which must be acceptable to the Owner.

(c) All bonds required by the Contract Documents to be purchased and maintained by Contractor shall be obtained from surety companies that are duly licensed or authorized in the State of California to issue Bonds for the limits so required. Such surety companies shall also meet such additional requirements and qualifications as provided in the General Conditions, Section 00700-1.8.

12. The Contractor may substitute securities for the amounts retained by the Owner to ensure performance of the work in accordance with the provisions of Section 22300 of the Public Contract Code.

13. As required by Section 6705 of the California Labor Code and in addition thereto, whenever work under the Contract involves the excavation of any trench or trenches five feet or more in depth, the Contractor shall submit in advance of excavations, a detailed plan showing the design of shoring, bracing, sloping, or other provisions to be made for worker protection from the hazard of caving ground during the excavation of such trench or trenches. If such plan varies from the shoring system standards established by the Construction Safety Orders of the Division of Industrial Safety in Title 8, Subchapter 4, Article 6, California Code of Regulations, the plan shall be prepared by a registered civil or structural engineer employed by the Contractor, and all costs therefore shall be included in the price named in the Contract for completion of the work as set forth in the Contract Documents. Nothing in this Section shall be deemed to allow the use of a shoring, sloping, or other protective system less effective than that required by the Construction Safety Orders. Nothing in this Section shall be construed to impose tort liability on the Owner, the Design Consultant, Construction Manager nor any of their agents, consultants, volunteers, or employees. The Owner's review of the Contractor's excavation plan is only for general conformance to the California Construction Safety Orders.

Prior to commencing any excavation, the Contractor shall designate in writing to the Construction Manager the "competent person(s)" with the authority and responsibilities designated in the Construction Safety Orders.

14. In accordance with Section 7104 of the Public Contract Code, whenever any work involves digging trenches or other excavations that extend deeper than four feet below the surface, the provisions of Section 00700-7.2, **Differing Site Conditions**, shall apply.

15. In accordance with Section 7103.5 of the Public Contract Code, the Contractor and subcontractors shall conform to the following requirements. In entering into a public works contract or a subcontract to supply goods, services, or materials pursuant to a public works contract, the Contractor or subcontractor offers and agrees to assign to the Owner all rights, title, and interest in and to all causes of action it may have under Section 4 of the Clayton Act (15 U.S.C. Section 15) or under the Cartwright Act [Chapter 2 (commencing with Section 16700) of Part 2 of Division 7 of the Business and Professions Code], arising from purchases of goods, materials or services pursuant to this Contract or the subcontract. Such assignment shall be made and become effective at the time the Owner tenders final payment to the Contractor, without further acknowledgment by the parties.

16. Pursuant to Public Contract Code Section 7100, the acceptance by the Contractor of an undisputed payment made under the terms of the Contract shall operate as, and shall be, a release to the Owner, and their duly authorized agents, from all claim of and/or liability to the Contractor arising by virtue of the contract related to those amounts. Disputed contract claims in stated amounts may be specifically excluded by the Contractor from the operation of the release.

17. In accordance with California Business and Professions Code Section 7030, the Contractor is required by law to be licensed and regulated by the Contractors' State License Board which has jurisdiction to investigate complaints against contractors if a complaint regarding a patent act or omission is filed within four years of the date of the alleged violation. A complaint regarding a latent act or omission pertaining to structural defects must be filed

within ten (10) years of the date of the alleged violation. Any questions concerning the Contractor may be referred to the Registrar, Contractors' State License Board, P.O. Box 26000, Sacramento, California 95826.

18. The acceptance of each payment made to Contractor under this Agreement shall constitute a warranty that all subcontractors, laborers and material suppliers on the Project have been paid for all work, material, labor provisions, provender, equipment, or other supplies and efforts made toward the construction of improvements.

19. **INDEMNIFICATION.** Contractor shall indemnify, defend with counsel acceptable to City, and hold harmless to the full extent permitted by law, the Owner and its officers, officials, employees, agents and volunteers, Design Consultant and its consultants for the Work and their respective agents and employees; and if one is designated by the Owner for the work, the Construction Manager and its consultants for the work and their respective agents and employees (collectively "the Indemnified Parties") in accordance with the requirements of Section 00800 – 2.1.6, Supplementary General Conditions.

20. **SEVERABILITY.** If any term or portion of this Agreement is held to be invalid, illegal, or otherwise enforceable by a court of competent jurisdiction, the remaining provisions of this Agreement shall continue in full force and effect.

IN WITNESS WHEREOF, Owner and Contractor have caused this Agreement to be executed the day and year first above written.

SANITARY DISTRICT NO. 5
A Public Entity

By _____
Tony Rubio, District Manager

CONTRACTOR _____

By _____
(CORPORATE SEAL)

ATTEST: _____

Address for giving notices:

Address

City

State

Zip

License No.: _____

Agent for services of process:

Finance Director

***** END OF SECTION ****

THIS PAGE INTENTIONALLY LEFT BLANK

SECTION 00610

FAITHFUL PERFORMANCE BOND

KNOW ALL MEN BY THESE PRESENTS: that, WHEREAS, the Board of Directors of the Sanitary District No. 5, Marin County, State of California, has awarded to _____, hereinafter designated as the "Principal," a Contract, the terms and provisions of which Contract are incorporated herein by reference, for constructing the **2024 Sewer Rehabilitation Project - Tiburon and Belvedere**, and

WHEREAS, said Principal is required under the terms of said Contract to furnish a bond for the faithful performance of said Contract;

NOW, THEREFORE, we the Principal, and _____, as surety, are held and firmly bound unto the Sanitary District No. 5, Marin County, California, in the penal sum of _____ Dollars (\$ _____), lawful money of the United States, being one hundred percent (100%) of the Contract amount, for the payment of which sum well and truly to be made, we bind ourselves, our heirs, executors, administrators and successors, jointly and severally, firmly by these presents.

THE CONDITION OF THIS OBLIGATION IS SUCH, that if the above bounden Principal, Principal's heirs, executors, administrators, successors or assigns, shall in all things stand to and abide by, and well and truly keep and faithfully perform the covenants, conditions and agreements in the said Contract and any alterations made as therein provided, on the Principal's part, to be kept and performed at the time and in the manner therein specified, and in all respects according to their true intent and meaning, and shall indemnify and save harmless the Sanitary District No. 5, its officers and agents, as therein stipulated, then this obligation shall be null and void; otherwise it shall be and remain in full force and virtue.

As a condition precedent to the satisfactory completion of the said Contract, the above obligation shall hold good for a period of one (1) year after the completion and acceptance of the said work, during which time, if the above bounden Principal, Principal's heirs, executors, administrators, successors or assigns shall fail to make full, complete and satisfactory repair and replacements or totally protect the said District from loss or damage made evident during said period of one (1) year from the date of acceptance of said work, and resulting from or caused by defective materials or faulty installation, in the prosecution of the work done, the above obligation shall be and remain in full force and virtue.

And the said Surety, for value received, hereby stipulates and agrees to waive the provisions of California Civil Code Section 2819 regarding consent to change, extension of time, alteration or addition to the terms of the Contract, or to the work to be performed thereunder, or the Specifications accompanying the same shall in any way affect its obligations on this bond; and it does hereby waive notice of any such change, extension of time, alteration or addition to the terms of the Contract, or to the work, or to the Specifications.

In the event the District, or its successors or assigns, shall be the prevailing party in an action brought upon this bond, then, in addition to the penal sum hereinabove specified, we agree to pay to the said District, or its successors or assigns, a reasonable sum on account of attorney's fees in such action, which sum shall be fixed by the court.

In WITNESS THEREOF, the above bounden parties have executed this instrument under their seals this _____ day of _____, 20____, the name and corporate seal of each corporate party being hereto affixed, and these presents duly signed by its undersigned representative, pursuant to authority of its governing body.

ATTEST:

Principal Secretary

Principal

(SEAL)By _____

Witness as to Principal

Address

Address

Witness to Surety

Surety

Address

Address

Telephone

Attorney-in-Fact

Address

If CONTRACTOR is partnership, all partners must execute BOND.

***** END OF SECTION *****

SECTION 00620

PAYMENT BOND

KNOW ALL MEN BY THESE PRESENTS:

That we, _____, as Principal, and _____, organized and existing under the laws of the State of _____, and authorized to execute bonds and undertaking as sole surety, as Surety, are held and firmly bound unto any and all persons named in California Civil Code Section 3181, whose claim has not been paid by the Contractor, company or corporation in the aggregate total of _____ Dollars (\$_____) (being 100% of the Contract amount) for payment whereof, well and truly to be made, said Principal and Surety bond themselves, their heirs, administrators, successors and assigns, jointly and severally, firmly by these presents.

The condition of the foregoing obligation is such that, whereas the above bounden Principal has entered into a Contract dated _____, 20____, with the Sanitary District No. 5 to do the following work, to wit: Construct the Sanitary District No. 5, **2024 Sewer Rehabilitation Project - Tiburon and Belvedere**.

NOW, THEREFORE, if the above bounden Principal or his/her subcontractors fail to pay any of the persons named in Section 3181 of the Civil Code of the State of California, or amounts due under the Unemployment Insurance Code with respect to work or labor performed under the Contract, or for any amounts required to be deducted, withheld and paid over to the Employment Development Department from the wages of employees of the Contractor or his/her subcontractor pursuant to Section 13020 of the Unemployment Insurance Code of the State of California, with respect to such work and labor, the surety will pay for the same, in the amount not exceeding the sum specified in this bond, and also, in case suit is brought upon this bond, a reasonable attorney's fee, to be fixed by the court.

This bond shall inure to the benefit of any person named in Section 3181 of the Civil Code of the State of California so as to give a right of action to them or their assignees in suit brought upon this bond.

This bond is executed and filed to comply with the provisions of the act of Legislature of the State of California as designated in Civil Code Section 3247 to 3252, inclusive, and all amendments thereto.

And the said Surety, for value received, hereby stipulates and agrees to waive the provisions of California Civil Code Section 2819 regarding consent to change, extension of time alteration, or addition to the terms of the Contract, or to the work to be performed thereunder, or the Specifications accompanying the same, shall in any way affect its obligations on this bond; and it does hereby waive notice of any such change, extension of time, alteration or addition to the terms of the Contract, or to the work, or to the Specifications.

In the event the District, or its successors or assigns, shall be the prevailing party in an action brought upon this bond, then, in addition to the penal sum hereinabove specified, we agree to pay to the said District, or its successors or assigns, a reasonable sum on account of attorney's fees in such action, which sum shall be fixed by the court.

IN WITNESS WHEREOF, the above bounden parties have executed this instrument under their seals this _____ day of _____, 20____, the name and corporate seal of each corporate party being hereto affixed and these presents duly signed by its undersigned representative, pursuant to authority of its governing body.

ATTEST:

Principal Secretary

Principal

(SEAL)By _____

Witness as to Principal

Address

Address

Witness to Surety

Surety

Address

Address

Telephone

Attorney-in-Fact

Address

If CONTRACTOR is partnership, all partners must execute BOND.
The signature of the Surety on this bond must be acknowledged before a Notary Public.

***** END OF SECTION *****

SECTION 00630

**ESCROW AGREEMENT FOR
SECURITY DEPOSITS IN LIEU OF RETENTION**

**2024 Sewer Rehabilitation Project
Tiburon and Belvedere**

This Escrow Agreement is made and entered into by and between; the Sanitary District No. 5, whose address is 2001 Paradise Drive, Tiburon, CA 94920; hereinafter called "Owner", and

_____ whose address is _____

hereinafter called "Contractor", and _____

whose address is _____

hereinafter called "Escrow Agent."

For the consideration hereinafter set forth, the Owner, Contractor, and Escrow Agent agree as follows:

1. Pursuant to Section 22300 of the Public Contract Code of the State of California, Contractor has the option to deposit securities which meet the requirements set forth in said Section 22300, with Escrow Agent, as a substitute for retention earnings required to be withheld by District pursuant to the Construction Contract entered into between Owner and Contractor for _____ in the amount of dated _____ (hereinafter referred to as the "Contract"). Alternatively, on written request of the Contractor, the Owner shall make payments of the retention earnings directly to the Escrow Agent. When Contractor deposits the securities as a substitute for Contract earnings, the Escrow Agent shall notify the Owner within ten (10) days of the deposit. The market value of the securities at the time of the substitution shall be at least equal to the cash amount then required to be withheld as retention under the terms of the Contract between the Owner and Contractor. Securities shall be held in the name of Owner, and shall designate the Contractor as the beneficial Owner.

2. Owner shall make progress payments to Contractor for such funds which otherwise would be withheld from progress payments pursuant to the Contract provisions, provided that the Escrow Agent holds securities in the form and amount specified above.

3. When the Owner makes payment of retentions earned directly to the Escrow Agent the Escrow Agent shall hold them for the benefit of the Contractor until such time as the escrow created under this Contract is terminated. The Contractor may direct the investment of the payments into securities. All terms and conditions of this agreement and the rights and responsibilities of the parties shall be equally applicable and binding when the Owner pays the Escrow Agent directly.

4. Contractor shall be responsible for paying all fees for the expenses incurred by Escrow Agent in administering the Escrow Account, and all expenses of the Owner. These expenses and payment terms shall be determined by the Owner, Contractor, and Escrow Agent.
5. The interest earned on the securities or the money market accounts held in escrow and all interest earned on that interest shall be for the sole account of Contractor and shall be subject to withdrawal by Contractor at any time and from time to time without notice to the Owner.
6. Contractor shall have the right to withdraw all or any part of the principal in the Escrow Account only by written notice to Escrow Agent accompanied by written authorization from Owner to the Escrow Agent that District consents to the withdrawal of the amount sought to be withdrawn by Contractor.
7. The Owner shall have a right to draw upon the securities in the event of default by the Contractor. Upon seven (7) days' written notice to the Escrow Agent from the Owner of the default, the Escrow Agent shall immediately convert the securities to cash and shall distribute the cash as instructed by the Owner.
8. Upon receipt of written notification from the Owner certifying that the Contract is final and complete, and that the Contractor has complied with all requirements and procedures applicable to the Contract, Escrow Agent shall release to Contractor all securities and interest on deposit less escrow fees and charges of the Escrow Account. The escrow shall be closed immediately upon disbursement of all moneys and securities on deposit and payments of fees and charges.
9. Escrow Agent shall rely on the written notifications from the Owner and the Contractor pursuant to Sections (5) to (8), inclusive, of this Agreement, and Owner and Contractor shall hold Escrow Agent harmless from Escrow Agent's release and disbursement of the securities and interest as set forth above.
10. The names of the persons who are authorized to give written notice or to receive written notice on behalf of the Owner and on behalf of Contractor in connection with the foregoing, and exemplars of their respective signatures are as follows:

On Behalf of Owner:

Title

Name

Signature

Address

Phone Number

On Behalf of Contractor:

Title

Name

Signature

Address

Phone Number

On Behalf of Escrow Agent:

Title

Name

Signature

Address

Phone Number

At the time the Escrow Account is opened, Owner and Contractor shall deliver to the Escrow Agent a fully executed counterpart of this Agreement.

IN WITNESS WHEREOF, the parties have executed this Agreement by their proper officers on the date first set forth above.

Owner:

Contractor:

Title

Title

Name

Name

Signature

Signature

***** END OF SECTION *****

SECTION 00650

GENERAL LIABILITY ENDORSEMENTS

INSURANCE ENDORSEMENT FORM A - COMMERCIAL GENERAL LIABILITY

INSURER: ISO FORM CG 20 10 11 85: (MODIFIED)
POLICY NUMBER: COMMERCIAL GENERAL LIABILITY
ENDORSEMENT NUMBER: EXHIBIT 1-A

THIS ENDORSEMENT CHANGES THE POLICY, PLEASE READ IT CAREFULLY.

ADDITIONAL INSURED — OWNERS, LESSEES OR CONTRACTORS (FORM B)

This endorsement modifies insurance provided under the following:

COMMERCIAL GENERAL LIABILITY COVERAGE PART.

SCHEDULE

Name of Organization Sanitary District No. 5, Nute Engineering, County of Marin, City of Tiburon, the City of Belvedere and each of their officials, officers, employees, agents, and volunteers.

WHO IS AN INSURED (Section II) is amended to include as an insured the person or organization shown in the Schedule, but only with respect to liability arising out of “your work” for that insured by or for you.

- | |
|---|
| <p>Modifications to ISO form CG 20 10 11 85:</p> <ol style="list-style-type: none"> 1. The insured scheduled above includes the Insured's officers, officials, employees and volunteers. 2. This insurance shall be primary as respects the insured shown in the schedule above, or if excess, shall stand in an unbroken chain of coverage excess of the Named Insured's scheduled underlying primary coverage. In either event, any other insurance maintained by the Insured scheduled above shall be in excess of this insurance and shall not be called upon to contribute with it. 3. The insurance afforded by this policy shall not be canceled except after thirty days prior written notice by certified mail return receipt requested has been given to the Entity. 4. Coverage shall not extend to any indemnity coverage for the active negligence of the additional insured in any case where an agreement to indemnify the additional insured would be invalid under Subdivision (b) of section 2782 of the Civil Code. |
|---|

Signature-Authorized Representative

Address

CG 20 10 11 85 Insurance Services Office, Inc. Form (Modified)
Note: ORGANIZATION or ENTITY on this form shall refer to SANITARY DISTRICT NO. 5 (SD5, or the DISTRICT).

THIS PAGE INTENTIONALLY LEFT BLANK

SECTION 00651

AUTO LIABILITY ENDORSEMENT (Form B-1)

SANITARY DISTRICT NO. 5 ("Owner")
Attention: District Manager
2001 Paradise Drive
Tiburon, CA 94920

**2024 Sewer Rehabilitation Project
Tiburon and Belvedere**

A. POLICY INFORMATION.

1. Insurance Company _____
Policy No. _____
 2. Policy Term (From) _____ (To) _____
Endorsement Effective Date _____
 3. Named Insured _____
 4. Address of Named Insured _____
 5. Limit of Liability Any One Occurrence/Aggregate
\$ _____
 6. Deductible or Self-Insured Retention (Nil unless otherwise specified):
\$ _____
-

B. POLICY AMENDMENTS.

This endorsement is issued in consideration of the policy premium. Notwithstanding any inconsistent statement in the policy to which this endorsement is attached or any other endorsement attached thereto it is agreed as follows:

1. **INSURED.** The Sanitary District No. 5, Nute Engineering, the Town of Tiburon, the City of Belvedere and each of their officers, officials, employees, agents and volunteers are included as additional insurers with regard to damages and defense of claims arising from ownership, operation, maintenance, use, loading or unloading of any auto owned, leased, hired or borrowed by the Named Insured, regardless of whether liability is attributable to the Named Insured or a combination of the Named Insured and the Sanitary District No. 5, Nute Engineering, the Town of Tiburon, the City of Belvedere and each of its officers, officials, employees, agents and volunteers.

2. CONTRIBUTION NOT REQUIRED. As respects work performed by the Named Insured for or on behalf of the Owner, the insurance afforded by this policy shall: (a) be primary insurance as respects the Sanitary District No. 5, Nute Engineering, the Town of Tiburon, the City of Belvedere and each of their officers, officials, employees, agents and volunteers; or (b) stand in an unbroken chain of coverage excess of the Named Insured's primary coverage. In either event, any other insurance maintained by the Sanitary District No. 5, Nute Engineering, the Town of Tiburon, the City of Belvedere and each of their officers, officials, employees, agents and volunteers shall be excess of this insurance and shall not contribute with it.

3. SCOPE OF COVERAGE. The policy affords coverage to the Named Insured which is at least as broad as Insurance Services Office form number CA 0001 (Ed. 1/87) covering automobile liability, Code 1 ("any auto").

4. SEVERABILITY OF INTEREST. The insurance afforded by this policy applies separately to each insured who is seeking coverage or against whom a claim is made or a suit is brought, except with respect to the limits of the insurer's liability.

5. PROVISIONS REGARDING THE INSURED'S DUTIES AFTER ACCIDENT OR LOSS. Any failure to comply with reporting provisions of the policy shall not affect coverage provided to the Sanitary District No. 5, Nute Engineering, the Town of Tiburon, the City of Belvedere and each of their officers, employees, and agents.

6. CANCELLATION NOTICE. The insurance afforded by this policy shall not be suspended, voided, cancelled, reduced in coverage or in limits except after thirty (30) days prior written notice by Certified Return Receipt Requested has been given to the Owner. Such notice shall be addressed as shown in the heading of this endorsement.

C. INCIDENT AND CLAIM REPORTING PROCEDURE.

Incidents and claims are to be reported to the insurer at:

Attn: _____
(Title) (Department)

(Company)

Street Address)

(Agency) (State) (Zip Code)

(Telephone Number)

D. SIGNATURE OF INSURER OR AUTHORIZED REPRESENTATIVE OF THE INSURER.

I, _____ (print/type name), warrant that I have authority to bind the below-listed insurance company and by my signature hereon do so bind this company. By signature below, the surety warrants that if requested by the Owner, it will furnish a certified copy of the certificate of authority issued by the Insurance Commissioner of the State of California.

Signature of: _____
Authorized Representative
(original signature required on endorsement furnished to the Owner)

ORGANIZATION: _____ TITLE: _____

ADDRESS: _____ TELEPHONE: () _____

***** END OF SECTION *****

THIS PAGE INTENTIONALLY LEFT BLANK

SECTION 00700

GENERAL CONDITIONS

1.0 GENERAL

1.1 Contract Agreement

A bidder to whom award is made shall execute a written Contract Agreement and required supplementary documents and submit them to the Owner within ten (10) days after the Notice of Award has been mailed to the bidder at the address given in Section 00300, **BID FORM**. The Agreement shall be made in the form adopted by the Owner and incorporated in the Section 00500, **AGREEMENT**.

If the lowest responsive, responsible bidder to whom award is made fails to enter into the Agreement, as herein provided, the Bidder's Bond will become the property of the Owner, and an award may be made to the next lowest responsive, responsible bidder, and such bidder shall fulfill every stipulation embraced herein as if it were the party to whom the first award was made. A corporation, partnership, or joint venture to which an award is made will be required, before the Agreement is finally executed, to furnish evidence of its corporate existence and evidence that the officer signing the Agreement and bonds for the corporation is duly authorized to do so in the form of a Bid Proposal Certificate as included in Section 00300, Certificates.

In the event the Contractor is a joint venture of two or more contractors, the grants, covenants, provisos and claims, rights, power, privileges and liabilities of the Contract shall be construed and held to be several as well as joint. Any notice, order, direct request or any communication required to be or that may be given by the Owner or the Construction Manager to the Contractor under this Contract, shall be well and sufficiently given to all persons being the Contractor if given to any one or more of such persons. Any notice, request or other communication given by any one of such persons to the Owner or the Construction Manager under this Contract shall be deemed to have been given by and shall bind all persons being the Contractor.

If any part of the work to be done under this Contract is subcontracted, the subcontract shall be in writing and shall provide that all work to be performed thereunder shall be performed in accordance with the terms of the Contract Documents. The subcontracting of any or all of the work to be done will in no way relieve the Contractor of any part of its responsibility under the Contract. Certified copies of subcontract agreements will be provided by the Contractor to the Owner upon request.

The Contractor shall not assign, transfer, convey, or otherwise dispose of the Contract in whole or in part, or its right, title, or interest therein, or its power to execute such Contract, to any other person, firm, or corporation without previous consent in writing of the Owner. Any proposed assignment, transfer, convey and or other disposition without such written consent of this owner will be void.

1.2 **Written Notice and Service Thereof**

Any notice to any party relative to any part of this Contract shall be in writing and considered delivered and the service thereof completed, when said notice is posted, by certified or registered mail, to said party at its last given address, or delivered in person to the said party or its authorized representative of the work. This includes notice of change of address.

1.3 **Rights of Action**

No right of action shall accrue upon or by reason of this Agreement to or for the use or benefit of anyone other than the parties to this Agreement. The parties to this Agreement are the Contractor and the Owner.

1.4 **Plans and Specifications**

The Contract Documents are complementary; what is called for by one is as binding as if called for by all. It is the intent of the Drawings and Specifications to describe a functionally complete and operable Project (and all parts thereof) to be constructed in accordance with the requirements of the Contract Documents. Any work, materials or equipment that may reasonably be inferred from the requirements of the Contract Documents or from prevailing custom or trade usage as being required to produce this intended result will be furnished and performed whether or not specifically called for. When words or phrases that have a well-known technical or construction industry or trade meaning are used to describe Work, materials or equipment, such words or phrases shall be interpreted in accordance with that meaning. The intent of the Drawings specifically includes the intent to depict construction that complies with all applicable laws, codes and standards. Subject to applicable law, including but not limited to California Public Contract Code Section 4100 et seq., and the terms of this Contract governing subcontracting, the Divisions and Sections of the Specifications and identifications of any Drawings shall not control Contractor in dividing the Work among subcontractors or suppliers or delineating the work to be performed by any specific trade.

Reasonably implied parts of the Work shall be performed as “incidental work” even though absent from the Drawings and Specifications. “Incidental” work shall be performed by Contractor without extra cost to Owner. Incidental work includes any work not shown on Drawings nor described in Specifications, but which is necessary or normally or customarily required as a part of the Work shown on the Drawings or described in the Specifications, or is necessary or required to make each installation satisfactory, legally operable, functional, consistent with the intent of the Drawings and Specifications or the requirements of the Contract Documents. Incidental work shall be treated as if fully described in Specifications and shown on Drawings, and expense thereof shall be included in price bid.

Upon Notice to Proceed, the Contractor may obtain from the Owner, free of charge, ten (10) copies of the conformed Plans (half- size) and Specifications. The Contractor may also obtain from the Owner, free of charge, five (5) sets of full-size prints of the Plans. Additional sets of the prints and specifications may be procured at the cost of printing and binding. The Owner will also provide one electronic copy of the conformed plans and specifications upon receipt of an executed release from the Contractor. The Owner will furnish the release form at the Contractor’s request.

The Contractor shall keep on the Project site a copy of the Specifications and Drawings and shall at all times give the Construction Manager access thereto. Any Drawings included in the Specifications shall be regarded as part thereof and of the Contract. Anything mentioned in these Specifications and not shown on the Drawings, or shown on the Drawings and not mentioned in these Specifications, shall be of like effect as though shown or mentioned in both.

The Construction Manager will furnish from time to time such drawings, plans, profiles, and information as it may consider appropriate for the Contractor's guidance. Unless otherwise provided in the Contract Documents, it shall be the duty of the Contractor to see that all provisions are complied with in detail irrespective of the inspections of the Work during its progress by the authorized official or its representatives. Any failure on the part of the Contractor to observe the Contract Documents will be sufficient cause for the rejection of the Work at any time before its acceptance.

Wherever reference specifications are referred to in these Specifications without designation of year, the reference is to the current or revised specification effective at the time of the Owner receiving bids.

1.5 Applicability of all Paragraphs of Specifications

The technical specifications are presented in paragraphs for convenience. However, this presentation does not necessarily delineate trades or limits of responsibility. All paragraphs of the Specifications and Plans are interdependent and applicable to the Project as a whole.

The Specifications and all notes on the Drawings are directed to the Contractor and all work shall be performed by the Contractor even though phrases such as "the Contractor shall" or "shall be done by the Contractor" are omitted. Where terms such as "approved," "acceptable," "favorably reviewed," "review," "selected," "directed," "equivalent," "equal," or "satisfactory" are used, it shall mean by or to the Construction Manager and/or Design Consultant.

1.6 Contract Interpretation by the Construction Manager

Notwithstanding any omission from these Specification or the Drawings it shall be the duty of the Contractor to call the Construction Manager's attention to apparent errors or omissions and request instructions before proceeding with the work. The Construction Manager may, by appropriate instructions correct errors and supply omitted information, which instructions shall be as binding upon the Contractor as though contained in the original Specifications or Drawings.

Any discrepancies found between the Contract Documents and Project site conditions or any inconsistencies or ambiguities in the Contract Documents shall be immediately reported, in writing, to the Construction Manager. Questions regarding the meaning and intent of the Contract Documents shall be referred in writing by the Contractor to the Construction Manager with a Request for Information. The Construction Manager shall respond to the Contractor in writing with a decision within fifteen (15) days of receipt of the request, or if it is necessary to extend this period, the Construction Manager shall notify the Contractor in writing as to when a decision will be provided.

Work done by the Contractor after its discovery of such discrepancies, inconsistencies or ambiguities without such notice and prior to response from the Construction Manager shall be done at the Contractor's risk.

1.7 **Order of Precedence**

In resolving inconsistencies among two or more sections of the Contract Documents, precedence shall be given in the following order:

1. Addenda, Supplemental Agreements and Change Orders, the one dated later having precedence over another dated earlier.
2. Agreement
3. Permits
4. General Requirements
5. Supplementary General Conditions
6. General Conditions
7. Instructions to Bidders
8. Project Plans
9. Technical Specifications
10. Typical Details
11. Reference/Standard Specifications
12. Reference/Standard Plans

Figure dimensions on Drawings shall govern over scaled dimensions, and detailed Drawings shall govern over general or standard Drawings.

1.8 **Bonds**

The successful bidder shall, at the time of signing the Contract, furnish surety bonds executed by a surety admitted to conduct business in California using the bond forms included in the bid package.

The payment bond shall be in amount equal to one hundred percent (100%) of the Contract Amount and shall be for payment of just claims for materials, equipment, labor and subcontractors employed by the Contractor thereon.

The faithful performance bond shall be in an amount equal to one hundred percent (100%) of the Contract Amount and shall be for the faithful performance of the Contract, and for the fulfillment of such other requirements as may be provided by Law. The performance bond shall

remain in effect to guarantee the repair and replacement of defective equipment, materials, and workmanship, and payment of damages sustained by the Owner on account of such defects, discovered within one (1) year after final acceptance by the Owner, for the work performed under the Contract, which shall remain in effect for a period of one (1) year, to guarantee the repair and replacement, and payments for damages.

Attorneys-in-fact, who sign bid bonds or contract bonds, must file with each bond a notarized and effectively dated copy of their power of attorney as required on bond forms supplied by the Owner for Contractor use in Section 00610 and 00620.

The surety company shall familiarize itself with all of the conditions and provisions of this Contract, and it waives the right of special notification of any change or modification of this Contract or of extension of time, or of decreased or increased work, or of the cancellation of the Contract, or of any other act or acts by the Owner or its authorized agents under the terms of this Contract; and failure to so notify the aforesaid surety companies of changes shall not relieve the surety companies of their obligations under this Contract.

1.9 **Penalty for Collusion**

If, at any time, it is found that the person, firm, or corporation to whom the Contract has been awarded has, in presenting any bid or bids, colluded with any other party or parties, then the Contract shall be null and void, and the Contractor and its sureties shall be liable for loss or damage which the Owner may suffer thereby, and the Owner may advertise for new bids.

1.10 **Rights and Remedies**

The duties and obligations imposed by the Contract Documents and the rights and remedies available thereunder shall be in addition to, and not a limitation of, any duties, obligations, rights, and remedies otherwise imposed or available by law.

No action or failure to act by the Owner, the Design Consultant, or the Construction Manager shall constitute a waiver of any right or duty afforded any of them under the Contract, nor shall any such action or failure to act constitute an approval of or acquiescence in any breach thereunder, except as may be specifically agreed in writing.

2.0 CONTRACT ADMINISTRATION

2.1 **Administration of the Contract**

The Owner's Representative, the Construction Manager, and the Design Consultant will provide administration of the Contract as hereinafter described. These parties are designated in Section 00800-1.4, **Contract Administration**. If the status of any of the above parties should change, the Owner will provide written notice to the Contractor of such change.

In case of the termination of the employment of the Design Consultant or the Construction Manager, the Owner shall appoint a Design Consultant or a Construction Manager whose status under the Contract Documents shall be that of the former Design Consultant or Construction Manager, respectively.

2.2 Owner's Representative

2.2.1 General - The Owner's Representative has the authority to act on behalf of the Owner on change orders, field orders, progress payments, Contract decisions, acceptability of the Contractor's work, and early possession.

2.2.2 Change Orders/Field Orders - The Owner's Representative has the authority to accept or reject change orders, field orders and cost proposals submitted by the Contractor or as recommended by the Construction Manager.

2.2.3 Progress Payments - The Owner's Representative has the authority to accept or reject requests for progress payments which have been submitted by the Contractor and recommended by the Construction Manager.

2.2.4 Contract Decisions - Should the Contractor disagree with the Construction Manager's decision with respect to the Contract, the Contractor may appeal to the Owner's Representative in accordance with the provisions of the Contract.

2.2.5 Acceptability of Work - The Owner's Representative has the authority to make the final determination of the acceptability of the Work. The Owner's Representative also has the authority to accept or reject the Design Consultant's recommendations regarding retention of defective work as provided.

2.3 Construction Manager

2.3.1 General - The Construction Manager is a representative of the Owner employed to act as advisor and consultant to the Owner in construction matters related to the Contract. The term Construction Manager may include more than one individual to perform contract administration and construction observation. Hereinafter, the term Construction Manager includes any and all representatives working under the direction of the Construction Manager.

All instructions to the Contractor and all communications from the Contractor to the Owner or the Design Consultant shall be forwarded through the Construction Manager. The Construction Manager will have authority to act on behalf of the Owner only to the extent provided in the Contract Documents. The Owner has delegated its authority to the Construction Manager to make initial decisions regarding questions which may arise as to the quality or acceptability of materials furnished and work performed, and as to the manner of performance and rate of progress of the work under the Contract. The Construction Manager shall interpret the intent and meaning of the Contract and shall make initial decisions with respect to the Contractor's fulfillment of the Contract and the Contractor's entitlement to compensation. The Contractor shall look initially to the Construction Manager in matters relating to the Contract.

The Construction Manager's authority to act under Paragraph 00700-2.1, **Administration of the Contract**, and any decision made by it in good faith either to exercise or not to exercise such authority, shall not be interpreted or construed as control or responsibility of any of the work performed under this Contract.

2.3.2 Owner Representative - The Construction Manager will observe the progress, quality, and quantity of the Work to determine, in general, if the Work is proceeding in accordance with the provisions of the Contract Documents. The Construction Manager shall not be responsible

for construction means, methods, appliances techniques, sequences, or procedures, or for safety precautions and programs in connection with the Work.

In accordance with the provisions detailed elsewhere in these General Conditions, the Construction Manager will make decisions relative to all matters of interpretation or execution of the Contract Documents.

2.3.3 Observation and Inspections of Construction - The Construction Manager shall observe the construction and shall have the authority to reject work and materials which do not conform to the Contract Documents, and to require special inspection or testing.

Observation and inspection by an inspector is not an authorization to revoke, alter, or waive any requirements of the Specifications. Observation and inspection is the authorization to call the attention of the Contractor to any failure of the Work, materials or workmanship to conform to the Contract Documents. The inspector shall have this authority including the ability to reject materials or, in any emergency, suspend the Work. The Contractor may appeal any such issue which it disagrees with to the Construction Manager for decision. If the decision of the Construction Manager is not satisfactory to the Contractor, the Contractor may appeal such decision to the Owner's Representative.

2.3.4 Acceptability of the Work - The Construction Manager has the authority to make a recommendation as to the acceptability of the Work.

2.3.5 Change Orders - The Construction Manager has the authority to initiate change orders; to reject change orders proposed by the Contractor or Design Consultant; to negotiate and recommend acceptance of change orders; or to order minor changes in the Work at no cost to the Owner.

2.3.6 Construction Schedule - The Construction Manager has the authority to review and recommend acceptance of the progress schedule submitted by the Contractor at the start of the Work and subsequent significant revisions for conformance to the specified sequence of work and logic.

2.3.7 Progress Payments - The Construction Manager has the authority to recommend acceptance or rejection of requests for progress payments which have been submitted by the Contractor.

2.3.8 Final Payment - The Construction Manager, with the assistance of the Design Consultant, will conduct inspections to determine the dates of substantial completion of the Work and final completion of the Work, and will receive and forward to the Owner, for the Owner's review, written warranties, and related documents required by the Contract and assembled by the Contractor.

2.4 Design Consultant

2.4.1 General - The Design Consultant will have the authority to act on behalf of the Owner only to the extent provided in the Contract Documents.

2.4.2 Interpretations - The Design Consultant has the authority to be the initial interpreter of the technical requirements of the Contract Documents. Either party to the Contract may make written request to the Construction Manager for interpretations necessary for the proper execution or progress of the Work. The Construction Manager shall refer such written requests to the Design Consultant, who will render such interpretations. Where the Contractor has requested an interpretation from the Construction Manager, or been notified by the Construction Manager that such interpretation has been requested by the Owner, any work done before receipt of such interpretations, if not in accordance with same, shall be removed and replaced or adjusted as directed by the Construction Manager without additional expense to Owner.

2.4.3 Acceptability of the Work - The Design Consultant has the authority to make a recommendation as to the acceptability of the Work. The Design Consultant has the authority to recommend acceptance regarding the retention of defective work.

2.4.4 Submittal - The Design Consultant shall receive, through the Construction Manager, shop drawings, product data and samples for review in accordance with Section 01340.

The Design Consultant has the authority to review and take other appropriate action upon the Contractor's submittal such as shop drawings, product data and samples, but only for conformance with the design concept of the Work and the information given in the Contract Documents.

3.0 OWNER

3.1 General

The Owner, acting through the Owner's Representative or the Construction Manager, shall have the authority to act as the sole judge of the Work and materials with respect to both quantity and quality as set forth in the Contract.

3.2 Attention to Work

The Owner's, Construction Manager's and Design Consultant's representatives are designated in Section 00800-1.4, **Contract Administration**. The Construction Manager's designated representative will normally be available at the Project site of the Work. An alternate representative will be designated when the designated Construction Manager's representative is not available at the Project site of the Work. The Design Consultant may assign a representative to be available at the Project Site of the Work.

3.3 Observation and Inspection

In addition to the Construction Manager's designated representative, the Owner may provide one or more inspectors to the Construction Manager to observe the work and with the same authority as provided for in Section 00700-2.3.3, **Observation and Inspections of Construction**. Separate and independent from the observations and inspections above, the project may be inspected by Building Officials or Fire Officials for code compliance. Such inspectors shall have the authority provided to them by local jurisdiction.

3.4 **Owner's Right to Use or Occupy**

The Owner reserves the right, prior to Substantial Completion, to occupy, or use, any completed part or parts of the Work, providing these areas have been approved for occupancy by the Owner. The exercise of this right shall in no way constitute an acceptance of such parts, or any part of the Work, nor shall it in anyway affect the dates and times when progress payments shall become due from the Owner to the Contractor or in any way prejudice the Owner's rights in the Contract, or any bonds guaranteeing the same. The Contract shall be deemed completed only when all the Work contracted has been duly and properly performed and accepted by the Owner.

Prior to such occupancy or use, the Owner and Contractor shall agree in writing regarding the responsibilities assigned to each of them for payments, security, maintenance, heat, utilities, damage to the Work, insurance, the period for correction of the Work, and the commencement of warranties required by the Contract Documents.

In exercising the right to occupy or use completed parts of the Work prior to the Substantial Completion thereof, the Owner shall not make any use which will materially increase the cost to the Contractor, without increasing the Contract Amount, nor materially delay the completion of the Contract, without extending the time for completion.

3.5 **Owner's Right to Carry Out the Work**

If the Contractor should neglect to prosecute the work properly or fail to perform any provision of the Contract, and fails within five (5) days after receipt of written notice from the Owner to commence and continue correction of such neglect or deficiency with diligence and promptness, the Owner may, and without prejudice to any other remedy, make good such default, neglect or failure.

The Owner also reserves the right to perform any portion of the work due to an emergency threatening the safety of the Work, public, Owner, and any property or equipment.

In either case, a Change Order shall be issued unilaterally deducting from the payments then or thereafter due the Contractor the cost of correcting such deficiencies and/or for performing such work, including compensation for the Design Consultant's, the Construction Manager's, and Owner's additional services made necessary by such default, neglect, failure or emergency.

3.6 **Owner's Right to Perform Work and to Award Separate Contracts**

The Owner reserves the right to perform work related to the Project with the Owner's own forces, and to award separate contracts in connection with the Project or other work on the Project site. If the Contractor claims that delay, damage, or additional cost is involved because of such action by the Owner, the Contractor shall make such claim as provided elsewhere in the Contract Documents.

When separate contracts are awarded for different portions of the Project or other work on the Project site, the term "Contractor" in the Contract Documents in each case shall mean the contractor who executes each separate Agreement.

The Owner will provide for the coordination of the work of the Owner's own forces and of each separate contractor with the Work of the Contractor, who shall cooperate therewith as provided in Section 00700-4.10, **Cooperation with Other Contractors**.

3.7 **Responsibility of the Owner**

The Owner shall not be held responsible for the care or protection of any material or parts of the work prior to the final acceptance, except as expressly provided in these Specifications.

4.0 **CONTRACTOR**

4.1 **Status of Contractor and Subcontractors**

4.1.1 It is stipulated and agreed that the Contractor shall be an independent contractor in the performance of this Contract and shall have complete charge of persons engaged in performance of the Work. The Contractor shall perform the Work in accordance with its own means, methods, and appliances subject to compliance with the requirements of the Contract.

4.1.2 Subcontractors will not be recognized as having a direct relationship with the Owner. The persons engaged in the work, including employees of subcontractors and suppliers, will be considered employees of the Contractor and their work shall be subject to the provisions of the Contract. References in the Project Manual to actions required of subcontractors, manufacturers, suppliers, or any person other than the Contractor, the Owner or the Construction Manager shall be interpreted as requiring that the Contractor shall require such subcontractor, manufacturer, supplier or person to perform the specified action.

The Contractor shall not employ any subcontractors that are not properly licensed in accordance with State law. Prior to commencement of any work by a subcontractor, the Contractor shall submit verification to the Construction Manager that the subcontractor is properly licensed for the work it will perform.

The removal and/or substitution of any subcontractor listed in Section 00430, **DESIGNATION OF SUBCONTRACTORS**, shall be made by the Contractor and Owner as provided for in Public Contract Code Section 4100 et. seq.

4.2 **Contractor's Representative**

The Contractor shall designate in writing, before starting work, an authorized representative who shall have complete authority to represent and to act for the Contractor. Said authorized representative, or designated alternate, that has the authority to act in matters relating to the Contract, shall be personally present at the Project site at all times while work is actually in progress on the Contract. During periods when the Work is suspended, arrangements acceptable to the Construction Manager shall be made for any emergency work that may be required. The Contractor's authorized representative, or designated alternate(s), shall be fluent and proficient in the English language in order to understand, receive, and carry out oral and written communications or instructions relating to all job functions and responsibilities.

When the Contractor consists of two or more persons, firms, partnerships, or corporations functioning on a joint venture basis, said Contractor shall designate in writing to the Construction Manager, the name of their authorized representative who shall have supreme

authority to direct the work and to whom orders will be given by the Construction Manager, to be received and obeyed by the Contractor.

Information shall include the representative's name, street address, town, and telephone number, cell phone number and the mailing address if different from the street address.

The Contractor's authorized representative shall give its personal attention to and shall supervise the Work to the end that it shall at all reasonable times be prosecuted faithfully; and when the authorized representative or designated alternate is not personally present on the Work, the representative shall at all reasonable times be represented by a competent superintendent or foreman who shall receive and obey all instructions or orders given under this Contract, and who shall have full authority to supply materials, tools, and labor without delay, and who shall be the legally appointed representative of the Contractor. The Contractor shall be liable for the faithful observation of any instructions delivered to the Contractor or to its authorized representative.

4.3 **Use of Owner's Site**

With the approval of the Construction Manager, the Contractor may use portions of the Owner's site for storage of construction equipment, materials and field offices. The Owner will not accept any responsibility for damage to or loss of the Contractor's equipment or materials stored on any Project related site caused by vandalism, nature, or otherwise, suffered by the Contractor. Protection of all construction equipment, stores, and supplies shall be the sole responsibility of the Contractor. Where additional work space is desired by the Contractor or where the Owner cannot provide the space to the Contractor, it shall be the Contractor's sole responsibility and expense to obtain such a space for its use.

4.4 **Permits and Licenses**

The requirements for permits and licenses and payment are specified in Section 01030-1.02.

4.5 **Compliance with Laws**

The Contractor shall keep itself and its subcontractors fully informed of all existing and future legislated State and Federal Laws and City and County ordinances and regulations which in any manner affect those engaged or employed in the Work, or the materials and equipment used in the Work, or which in any way affect the conduct of the Work, and all such orders and decrees of bodies or tribunals having any jurisdiction or authority over the same. If any discrepancy or inconsistency is discovered in the Drawings, Specifications, or in any other part of this Contract, in relation to any such law, ordinance, regulation, order or decree, the Contractor shall immediately report the same to the Construction Manager in writing. The Contractor shall at all times observe and comply with all such existing and future laws, ordinances, regulations, orders and decrees; and shall protect, indemnify, and defend the Sanitary District No. 5, Town of Tiburon, the Construction Manager, the Design Consultant, and all of their officers, officials, employees, agents, volunteers, and servants against any claim or liability arising from or based upon the violation of any such law, ordinance, regulation, order, or decree, whether by the Contractor itself, employees, or its subcontractors. Particular attention is called to the following:

4.5.1 **Eight Hour Day Limitation** - In accordance with the provisions of Division 2, Part 7, Chapter 1, Article 3 of the Labor Code, State of California, and in particular Sections 1810 to 1815 inclusive, thereof, eight (8) hours labor shall constitute a days' work and no laborer,

worker, or mechanic in the employ of said Contractor, or any subcontractor doing or contracting to do any part of the Work contemplated by this Contract, shall be required or permitted to work more than eight (8) hours in any one calendar day, and forty (40) hours in any one calendar week unless compensated at not less than time and a half as set forth in California Labor Code Section 1815. However, if the prevailing wage determination requires a higher rate of pay for overtime than is required under said Section 1815, then the overtime rate must be paid, as specified in California Code of Regulation Title 8, Group 3, Section 16200(a)(3)(F). The Contractor and each subcontractor shall also keep an accurate record showing the names and actual hours worked of all workers employed by them in connection with the work contemplated by this Contract, which record shall be open at all reasonable hours for the inspection of the Owner or its officers or agents and by the Division of Labor Standards Enforcement of the Department of Industrial Relations, their deputies or agents; and it is hereby further agreed that said Contractor shall forfeit as a penalty to the Owner, the sum of Twenty-Five and No/100 Dollars (\$25.00) for each laborer, worker or mechanic employed in the execution of this Contract by the Contractor or by any subcontractor for each calendar day during which such laborer, worker or mechanic is required or permitted to labor more than eight (8) hours in any one calendar day and forty (40) hours in one calendar week in violation of these provisions.

4.5.2 Prior to commencing the Work, Contractor shall comply with the provisions of Labor Code 1777.5, including but not limited to the submission of contract award information to an applicable apprenticeship program that can supply apprentices to the site of the Work. Such information shall include an estimate of journeyman hours to be performed under this Contract, the number of apprentices proposed to be employed, and the approximate dates the apprentices would be employed. A copy of this information shall be submitted to the Owner if requested by the Owner.

A determination by the Chief of the Division of Apprenticeship Standards that Contractor or its subcontractors have knowingly violated Labor Code 1777.5 shall forfeit as a civil penalty an amount not exceeding one hundred dollars (\$100) for each full calendar day of noncompliance. Contractor or its subcontractor, who knowingly commits a second or subsequent violation of Labor Code 1777.5 within a three-year period, where the noncompliance results in apprenticeship training not being provided as required, shall forfeit as a civil penalty the sum of not more than three hundred dollars (\$300) for each full calendar day of noncompliance. Upon the receipt of a determination that a civil penalty has been imposed by the Chief of the Division of Apprenticeship Standards, the Owner shall withhold the amount of the civil penalty from the next progress payment then due or to become due Contractor.

4.5.3 Receipt of Workers' Wages, Fee for Registering or Placing Persons In Public Works - Attention is directed to the provisions of sections 1778 and 1779 of the California Labor Code, which read as follows:

"Section 1778. Every person, who individually or as a representative of an awarding or public body or officer, or as a contractor or subcontractor doing public work, or agent or officer thereof, who takes, receives or conspires with another to take or receive, for its own use or the use of any other person any portion of the wages of any workman or working subcontractor, in connection with services rendered upon any public work is guilty of a felony."

"Section 1779. Any person or agent or officer thereof who charges, collects, or attempts to charge or collect, directly or indirectly, a fee or valuable consideration for registering any person for public work, or for giving information as to where such employment may be procured, or for placing, assisting in placing, or attempting to place, any person in public work, whether the person is to work directly for the state, or any political subdivision or for a contractor or subcontractor doing public work is guilty of a misdemeanor."

4.5.4 Labor Discrimination. Attention is directed to Section 1735 of the Labor Code, which reads as follows:

"No discrimination shall be made in the employment of persons upon public works because of the race, religious creed, color, national origin, ancestry, physical disability, mental disability, medical condition, marital status, or sex of such persons, except as provided in Section 12940 of the Government Code, and every contractor for public works violating this section is subject to all the penalties imposed for violation of this chapter."

4.5.5 Workers' Compensation Insurance - The provisions of Section 00800-2.1.2, Workers' Compensation Insurance, shall be considered as repeated herein.

4.5.6 Lateral and Subjacent Supports - Attention is directed to Section 832 of the Civil Code of the State of California relating to lateral and subjacent supports, and wherever structures or improvements adjacent to the excavation may be damaged by such excavation, the Contractor shall comply with this law. As provided in Labor Code Section 6707, a separate bid item is provided for costs of shoring and bracing of excavations five feet or more in depth.

4.5.7 Safety Standards - The Contractor shall comply with all applicable provisions of the Safety and Health Regulations of Construction, promulgated by the Secretary of Labor under Section 107 of the Contract Work Hours and Safety Standards Act (40 USC 327 et. seq.) as set forth in Title 29, C.F.R., CAL/OSHA, and the regulations issued thereunder. Compliance shall be the Contractor's sole responsibility, and neither the Owner, the Construction Manager nor the Design Consultant shall have any liability for non-compliance. See Section 00700-4.7, Safety, for additional safety requirements.

4.6 Compliance with Environmental Laws

During construction, the Contractor shall comply with all pertinent requirements of Federal, State, and local environmental laws and regulations, including, but not limited to, the Federal Clean Air Act, State and local air pollution and noise ordinances, construction site erosion control regulations. Specific requirements may also be further specified within the contract documents including any and all applicable permits.

4.7 Safety

4.7.1 Contractor's Safety Responsibility - The Contractor shall be solely and completely responsible for conditions of the jobsite, including safety of all persons and property during performance of the Work. This requirement shall apply continuously and not be limited to normal working hours. Safety provisions shall conform to U.S. Department of Labor (OSHA), the California Occupational Safety and Health Act (CalOSHA), and all other applicable Federal, State, County, and local laws, ordinances, codes, including but not limited to the requirements

set forth below, and any regulations that may be detailed in other parts of these Contract Documents. In the event of conflicting requirements, the most stringent requirement as it pertains to the Contractor's safety responsibility, shall be followed by the Contractor.

No provision of the Contract Documents shall act to make the Owner, the Construction Manager, Design Consultant or any other party than the Contractor responsible for safety. The Contractor agrees that for purposes of California Labor Code Section 6400 and related provisions of law the Contractor, the Contractor's privities and any other entities acting pursuant to this contract will be "employers" responsible for furnishing employment and a place of employment that is safe and healthful for the employees, if any, of such entities acting pursuant to this contract and that neither the Owner nor the Construction Manager, Design Consultant or their respective officers, officials, employees, agents or volunteers or other authorized representatives will be responsible for having hazards corrected and /or removed at the location(s) where the work is to be performed. The Contractor agrees that neither the Owner nor the Construction Manager, Design Consultant or their respective officers, officials, employees, agents or volunteers or other authorized representatives will be responsible for taking steps to protect the Contractor's employees from such hazards, or for instructing the Contractor's employees to recognize such hazards or to avoid the associated dangers. The Contractor agrees that with respect to the work to be performed under this contract and the location(s) where such work is to be performed, the Contractor will be responsible for not creating hazards, and for having hazards corrected and/or removed. The Contractor agrees that through the safety obligations contained in this contract and the Contractor's own inspection of the site(s) where the contract work is to be performed, the Contractor is aware and has been notified of the hazards to which the Contractor's employees may be exposed in the performance of contract work. The Contractor has taken and/or will take appropriate, feasible steps to protect the Contractor's employees from such hazards, and has instructed and/or will instruct its employees to recognize such hazards and how to avoid the associated dangers. The Contractor agrees that neither the Owner nor the Construction Manager, Design Consultant or their respective officers, officials, employees, agents or volunteers or other authorized representatives will be "employers" pursuant to California Labor Code Section 6400 and related provisions of law with respect to the Contractor, the Contractor's privities or other entities acting pursuant to this contract.

The Contractor shall indemnify, defend and hold Owner and Construction Manager, Design Consultant and their respective officers, officials, employees, agents and volunteers or other authorized representatives harmless to the full extent permitted by law concerning liability related to the Contractor's safety obligations in accordance with Section 00800 - 2.1.6, Indemnification.

If death or serious injuries or serious damages are caused, the accident shall be reported immediately by telephone or messenger to both the Construction Manager and the Owner. In addition, the Contractor shall furnish the Construction Manager with a copy of the Employer's Report of Injury immediately following any incident requiring the filing of said report during the prosecution of the Work under this Contract. The Contractor shall also furnish the Construction Manager with a copy of the Employer's Report of Injury involving any subcontractors on this Project. The Contractor shall make all reports as are, or may be, required by any authority having jurisdiction, and permit all safety inspections of the Work being performed under this Contract.

If a claim is made by anyone against the Contractor or any subcontractor on account of any accident, the Contractor shall promptly report the facts in writing to the Construction Manager, giving full details of the claim.

4.7.2 Safety Program - The Contractor shall establish, implement, and maintain a written injury prevention program as required by Labor Code Section 6401.7. Before beginning the Work, the Contractor shall prepare and submit to the Construction Manager a written Contractor Safety Program that provides for the implementation of all of the Contractor's safety responsibilities in connection with the Work at the Project site. The coordination of that program and its associated procedures and precautions with safety programs, precautions and procedures of each of its subcontractors and other Contractors performing work at the Project site. The Contractor shall be solely responsible for initiating, maintaining, monitoring, coordinating, and supervising all safety programs, precautions, and procedures in connection with the Work and for coordinating its programs, precautions, and procedures of the other contractors and subcontractors performing the Work at the Project site. The Safety Program should contain all the necessary elements for the Contractor to administer its program on the Project site. At a minimum, this written Safety Program shall address the elements required by Labor Code Section 6401.7.

The Contractor's compliance with requirements for safety and/or the Construction Manager's review of the Contractor's Safety Program shall not relieve or decrease the liability of the Contractor for safety. The Construction Manager's review of the Contractor's Safety Program is only to determine if the above listed elements are included in the program.

4.7.3 Safety Supervisor - The Contractor shall appoint an employee as safety supervisor who is qualified and authorized to supervise and enforce compliance with the Safety Program. The Contractor shall notify the Construction Manager in writing prior to the commencement of work of the name of the person who will act as the Contractor's safety supervisor and furnish the safety supervisor's resume to the Construction Manager.

The Contractor will, through and with its Safety Supervisor, ensure that all of its employees and its subcontractors of any tier, fully comply with the Project Safety Policies. The Safety Supervisor shall be a full-time employee of the Contractor whose responsibility shall be for supervising compliance with applicable safety requirements on the Project site and for developing and implementing safety training classes for all job personnel. The Owner shall have the authority to require removal of the Contractor's Safety Supervisor if the representative is judged to be improperly or inadequately performing the duties; however, this authority shall not in any way affect the Contractor's sole responsibility for performing this work safely, nor shall it impose any obligation upon the Owner to ensure the Contractor performs its work safely.

4.7.4 Safety and Protection - The Contractor shall take all necessary precautions to prevent damage, injury, and loss to:

- All employees on the Project, employees of all subcontractors, and other persons and organizations who may be affected thereby;
- All the Work and materials and equipment to be incorporated therein, whether in storage on or off the site; and
- Other property at the site or adjacent thereto, including trees, shrubs, lawns, walks, wetlands, pavements, roadways, structures, utilities, and underground facilities not designated for removal, relocation, or replacement in the course of construction.

The Contractor shall comply with all applicable laws and regulations of any public body having jurisdiction for the safety of persons or property or to protect them from damage, injury or loss and shall erect and maintain all necessary safeguards for such safety and protection. The Contractor shall notify owners of adjacent property and of underground facilities and utility districts when prosecution of the Work may affect them and shall cooperate with them in the protection, removal, relocation, and replacement of their property. All injury or loss to any property caused, directly or indirectly, in whole or in part, by the Contractor, any subcontractor, supplier or any other person or organization directly or indirectly employed by any of them to perform or furnish any of the Work or anyone for whose acts any of them may be liable, shall be remedied by the Contractor.

4.7.5 Excavation Safety - In accordance with the provisions of Section 6705 of the Labor Code, the Contractor shall submit, in advance of excavation of any trench or trenches five feet or more in depth, a detailed plan showing the design of shoring, bracing, sloping, or other provisions to be made for worker protection from the hazard of caving ground during the excavation of such trench or trenches. If such plans vary from the shoring system standards set forth in the Construction Safety Orders of the Division of Industrial Safety in Title 8, Subchapter 4, Article 6, California Code of Regulations, the plans shall be prepared and signed by a registered civil or structural engineer employed by the Contractor, and all costs therefor shall be included in the price named in the Contract for completion of the work as set forth in the Contract Documents. Nothing in this section shall be deemed to allow the use of a shoring, bracing, sloping, or other protective system less effective than that required by the Construction Safety Orders. Nothing in this section shall be construed to impose a tort liability on the Owner, the Design Consultant, the Construction Manager, nor any of their officers, officials, employees, agents, consultants or volunteers. The Owner's review of the Contractor's excavation plan is only for general conformance to the Construction Safety Orders.

Prior to commencing any excavation, the Contractor shall designate in writing to the Construction Manager the "competent person(s)" with the authority and responsibilities designated in the Construction Safety Orders.

4.7.6 Safety Emergencies - In emergencies affecting the safety or protection of persons or the Work or property at the Project site or adjacent thereto, the Contractor, without special instruction or authorization from the Construction Manager, is obligated to act to prevent threatened damage, injury or loss. The Contractor shall give the Construction Manager prompt written notice if the Contractor believes that any significant changes in the Work or variations from the Contract Documents have been caused thereby.

4.7.7 Safety Violations - Should the Contractor fail to correct an unsafe condition, the Owner shall have the right to notify the Contractor through the Construction Manager that an unsafe condition may exist and must be corrected or the work in question can be stopped in accordance with Section 00700-6.6.1, Suspension of Work until the condition is corrected to the satisfaction of the Owner. No extension of time or additional compensation will be granted as a result of any stop order so issued. The notification and suspension of such work or the failure to provide such notification and suspension by the Owner shall not relieve the Contractor of its sole responsibility and liability for safety and the correction of any unsafe conditions.

The Owner shall have the authority to require the removal from the project of any worker and the foreman and/or superintendent in responsible charge of the work where safety violations occur.

4.7.8 Equipment Safety Provisions - The completed Work shall include all necessary permanent safety devices, such as machinery guards and similar safety items, required by the State and Federal (OSHA) industrial authorities and applicable local and national codes. Further, any features of the Work, including Owner-selected equipment, subject to such safety regulations shall be fabricated, furnished, and installed in compliance with these requirements. All equipment furnished shall be grounded and provided guards and protection as required by safety codes. Where vapor-tight or explosion-proof electrical installation is required by safety codes, this shall be provided. Contractors and manufacturers of equipment shall be held responsible for compliance with the requirements included herein. The Contractor shall notify all equipment suppliers and subcontractors of the provisions of this paragraph.

4.7.9 Confined Spaces – The Project requires work in confined spaces and requires compliance with CAL/OSHA and Federal OSHA requirements. Confined spaces for the purposes of this section shall be as defined by the Division of Industrial Safety. Notwithstanding any classifications relative to the Tunnel Safety Orders, work within confined spaces of this project is subject to the definitions and applicable provisions of Section 5156 et. seq., Title 8, Division 1, Chapter 4, Subchapter 7, Group 16, Article 108 of California Code of Regulations.

In addition the Owner classifies the following existing facilities as confined space: the interior of sewers, vaults, manholes, reservoirs and any other such structure of space which is similarly surrounded by confining surfaces as to permit the accumulation of dangerous gases or vapors. The confined spaces are “permit” confined spaces as defined by OSHA and therefor entry is allowed only through compliance with a confined space entry permit program by the contractor that meets the requirements of CAL/OSHA Section 5157. While the above mentioned locations have been identified as permit confined spaces, other permit confined spaces may exist. It shall be the responsibility of the Contractor to identify and classify these confined spaces. Sources of ignition, including smoking, shall be prohibited in any confined space.

It is anticipated that the Contractor may encounter hazardous conditions within these permit confined spaces which include, but are not limited to the following:

- A. Exposure to hydrogen sulfide, methane, carbon dioxide and other gases and vapors commonly found in municipal sewers which could have or has the potential of having Immediate Danger to Life or Health Conditions (IDLH).
- B. Exposure to atmosphere containing insufficient oxygen to support human life.
- C. Exposure to combustible, flammable and/or explosive atmosphere.
- D. Exposure to sewage which may contain bacteriological, chemical and other constituents harmful to humans.
- E. Work in conditions where engulfment or entrapment may occur.
- F. Work in environments which may be slippery and/or have uneven work surfaces.
- G. Work in structures which have limited and/or restricted access and egress.
- H. Work in structures where workers may trip, slip and/or fall several feet.

4.7.10 Public Safety and Convenience - The Contractor shall conduct his work so as to ensure the least possible obstruction to traffic and inconvenience to the general public and the residents in the vicinity of the Work and to ensure the protection of persons and property. No road or street shall be closed to the public except with the permission of the Construction Manager and the proper governmental authority. Fire hydrants on or adjacent to the Work shall be accessible to fire fighting equipment. Temporary provisions shall be made by the Contractor to ensure the use of sidewalks, private and public driveways and proper functioning of gutters, sewer inlets, drainage ditches and culverts, irrigation ditches and natural water courses.

4.8 Provisions for Handling Emergencies

It is possible that emergencies may arise during the progress of the Work, which may require special treatment or make advisable extra shifts of labor forces to continue the Work for twenty-four (24) hours per day. These emergencies may be caused by damage or possible damage to nearby existing structures or property by reason of the work under construction, or by storm, accidents, or leakage. The Contractor shall be prepared in case of such emergencies to make all necessary repairs and shall promptly execute such work when required by the Construction Manager. The determinations made by the Construction Manager for handling emergencies shall be final and conclusive upon the parties.

Upon start of the Work, Contractor shall provide means for immediate emergency notification of Contractor's designated representative and designated emergency alternates.

4.9 Nonstandard Working Hours

The Contractor may be required to prosecute the Work at night or outside of the normal working hours. When required, ordered, or permitted by the Owner to work at night, the Contractor shall provide sufficient and satisfactory lighting and other facilities therefor. For work outside of the normal working hours, the Contractor shall receive no extra payment, but compensation shall be considered as having been included in the price stipulated for the Work, except for authorized work performed outside of the Contract requirements.

4.10 Cooperation with Other Contractors

This Paragraph shall serve as notice to the Contractor that the Owner may let other contracts for other work at or near the site of this work. The Contractor shall afford other contractors reasonable opportunity for the delivery and storage of their materials and the execution of their work, and shall properly connect and coordinate its work with theirs.

Should construction be under way by other forces or by other contractors within or adjacent to the limits of the work or in the vicinity of the work to be done under this Contract, the Contractor shall so conduct its operations as to interfere to the least possible extent with the work of such other forces or contractors.

Any difference or conflicts which may arise between the Contractor and any other forces or contractors, creating delays or hindrance to each other, shall be adjusted as determined by the Construction Manager.

5.0 CONTROL OF WORK AND MATERIAL

5.1 Means, Methods and Appliances

The means, methods and appliances adopted by the Contractor shall be planned and executed to produce the highest grade quality of work and will enable the Contractor to complete the Work in the time agreed upon. The Owner and Construction Manager shall not supervise, direct, or have control over, or be responsible for, Contractor's means, methods and appliances of construction or for the safety precautions and programs incident thereto, or for any failure of Contractor to comply with laws and regulations applicable to the furnishing or performance of Work. However, if at any time the means, methods and appliances appear inadequate or of inferior quality, the Construction Manager may order the Contractor to improve their character or efficiency, and the Contractor shall conform to such order; failure of the Construction Manager to order such improvement of methods of efficiency will not relieve the Contractor from its obligation to perform satisfactory work and to finish the Work in the time agreed upon.

5.2 Character of Workers

None but competent superintendents, forepersons and workers shall be employed on the Work. The Contractor shall remove from the Work any person who commits trespass, possesses firearms or other weaponry, is under the influence or is in the possession of alcohol or other illegal drugs/controlled substance, or is, in the opinion of the Contractor or Construction Manager, disorderly, dangerous, insubordinate, incompetent, or otherwise objectionable. Such discharge shall not be the basis of any claim for compensation or damages against the Owner, its officers, officials, employees, agents, and volunteers, the Design Consultant, the Construction Manager, and their partners, officers, employees, agents or any of its officers or representatives.

5.3 Materials and Workmanship

Unless otherwise indicated in these Specifications, or favorably reviewed by the Design Consultant, materials and equipment for the construction work shall be the best grade in quality of a manufacturer regularly engaged in the production of such materials and equipment or materials and equipment of comparable character. All materials must be of the specified quality and equal to approved samples, if samples have been submitted. All work shall be done and completed in the best workmanlike manner, obtainable in the local market. All permanent materials and equipment shall be new unless otherwise specified.

All defective work or materials shall be promptly removed from the premises by the Contractor, whether in place or not, and shall be replaced or renewed in such manner as the Construction Manager may direct. All materials and workmanship of whatever description shall be subjected to the inspection of, and rejection by, the Construction Manager if not in conformance with the Contract Documents.

Any defective material or workmanship, or any unsatisfactory or imperfect work which may be discovered before the final acceptance of the work or within one (1) year thereafter, shall be corrected immediately upon the receipt of notice from the Construction Manager, without extra charge, notwithstanding that it may have been overlooked in previous inspections and estimates. Failure to inspect work shall not relieve the Contractor from any obligation to perform sound and reliable work as herein described.

5.4 Existing Utilities

5.4.1 General - The location of known existing utilities and pipelines are shown on the Plans in their approximate locations. However, nothing herein shall be deemed to require the Owner to indicate the presence of existing service laterals or appurtenances whenever the presence of such utilities on the site of the Project can be inferred from the presence of other visible facilities, such as buildings, cleanouts, meter and junction boxes, on or adjacent to the site of the Project.

The Owner will assume the responsibility for the timely removal, relocation, or protection of existing main or trunkline utility facilities located on the Project site if such utilities are not identified by the Owner in the Contract Documents or which cannot reasonably be inferred from the presence of other visible facilities.

5.4.2 Utility Location - It shall be the Contractor's responsibility to determine the exact location and depth of all utilities, including service connections, which have been marked by the respective utility owners and which the Contractor believes may affect or be affected by the Contractor's operations. The Contractor shall not be entitled to additional compensation or time extensions for work necessary to avoid interferences nor for repair to damaged utilities if the Contractor does not expose all such existing utilities as required by this section.

Pursuant to Government Code Section 4216 the Contractor shall contact the appropriate regional notification center at least two (2) working days before performing any excavation. The Contractor shall request that the utility owners conduct a utility survey and mark or otherwise indicate the location of their service.

After the utility survey is completed, the Contractor shall commence "potholing" or hand digging to determine the actual location of the pipe, duct, or conduit. The Construction Manager shall be given notice prior to commencing potholing operations. The Contractor shall uncover all piping and conduits, to a point one (1) foot below the pipe, where crossings, interferences, or connections are shown on the Drawings, prior to trenching or excavating for any pipe or structures, to determine actual elevations. New pipelines shall be laid to such grade as to clear all existing facilities which are to remain in service for any period subsequent to the construction of the run of pipe involved.

5.4.3 Utility Relocation and Repair - If interferences occur at locations other than those indicated in the Contract Documents with reasonable accuracy, the Contractor shall notify the Construction Manager in writing. The Construction Manager will supply a method for correcting said interferences in accordance with the responsibilities of this section and Government Code Section 4215.

The Owner shall compensate the Contractor for the costs of locating and repairing damage not due to the failure of the Contractor to exercise reasonable care, and for removing or relocating such main or trunkline utility facilities not indicated in the Contract Documents with reasonable accuracy, and for the cost of equipment on the Project necessarily idled during such work. The payment for such costs will be made as provided in Section 00700-7.1, **Change Orders**. The Contractor shall not be assessed liquidated damages for delay in completion of the Project, when such delay is caused by the failure of the Owner or utility company to provide for removal or relocation of such utility facilities. Requests for extensions of time arising out of utility

relocation or repair delays shall be filed in writing to the Owner including evidence from the utility of said delay.

The public utility, where they are the owner of the effected utility, shall have the sole discretion to perform repairs or relocation work or permit the Contractor to do such repairs or relocation work at a reasonable price. The right is reserved to the Owner and the owners of utilities or their authorized agents to enter upon the Work area for the purpose of making such changes as are necessary for the rearrangement of their facilities or for making necessary connections or repairs to their properties. The Contractor shall cooperate with forces engaged in such work and shall conduct its operations in such a manner as to avoid any unnecessary delay or hindrance to the work being performed by such forces and shall allow the respective utilities time to relocate their facility.

When the Contract indicates that a utility is to be relocated, altered or constructed by others, the Owner will conduct all negotiations with the utility company and the work will be done at no cost to the Contractor, unless otherwise stipulated in the Contract.

Temporary or permanent relocation or alteration of utilities desired by the Contractor for its own convenience shall be the Contractor's responsibility and it shall make arrangements and bear all costs for such work.

6.0 PROGRESS OF THE WORK

6.1 Commencement of Work

Within thirty (30) calendar days after receipt of the required bonds and evidences of insurance and the executed Agreement from the Contractor, written Notice to Proceed will be given by the Owner to Contractor. Notwithstanding other provisions of the Contract, the Contractor shall not be obligated to perform work, and the Owner shall not be obligated to accept or pay for work performed by the Contractor, prior to Notice to Proceed. The Contractor shall provide the required Contract bonds and evidences of insurance prior to Notice to Proceed and commencing work at the site.

The Contractor shall commence the work covered by this Contract within ten (10) days after the date established in the Notice to Proceed for the commencement of Contract Time.

The Contractor shall give the Construction Manager written notice not less than two (2) working days in advance of the actual date on which the work will be started. The Contractor shall be entirely responsible for any delay in the work which may be caused by its failure to give such notice.

6.2 Contract Time

Time shall be of the essence of the Contract. The Contractor shall prosecute the work so that the various portions of the project shall be complete and ready for use within the time specified in Section 00800-1.1, **Time Allowed for Completion**. It is expressly understood and agreed by and between the Contractor and the Owner that the Contract Time for completion of the work described herein is a reasonable time taking into consideration the average climatic and economic conditions and other factors prevailing in the locality and the nature of the work.

6.3 Delays

6.3.1 Notice of Delays - When the Contractor foresees a delay in the prosecution of the Work and, in any event, immediately upon the occurrence of a delay, the Contractor shall notify the Construction Manager in writing of the probability of the occurrence and the estimated extent of the delay, and its cause. The Contractor shall take immediate steps to prevent, if possible the occurrence or continuance of the delay. The Contractor agrees that no claim shall be made for delays which are not called to the attention of the Construction Manager at the time of their occurrence.

6.3.2 Non-Excusable Delays - Non-excusable delays in the prosecution of the Work shall include delays which could have been avoided by the exercise of care, prudence, foresight, and diligence on the part of the Contractor or its subcontractors, at any tier level, or suppliers. The Contractor shall receive no compensation or time extension for such delay.

6.3.3 Excusable Delays - Excusable delays in the prosecution or completion of the Work shall include delays which result from causes beyond the control of the Contractor and Owner and which could not have been avoided by the exercise of care, prudence, foresight, and diligence on the part of the Contractor or its subcontractors, at any tier level, or suppliers. The Contractor shall receive no compensation for such delay unless such delay also qualifies for compensable dollars.

- A. Abnormal Delays - Delays caused by fire, unusual storms, floods, tidal waves, earthquakes, strikes, labor disputes, freight embargoes, and shortages of materials shall be considered as excusable delays insofar as they prevent the Contractor from proceeding with at least seventy-five (75) percent of the normal labor and equipment force for at least five (5) hours per day toward completion of the current critical activity item(s) on the latest favorably reviewed progress schedule.
- B. Weather Delays - Should inclement weather conditions or the conditions resulting from weather prevent the Contractor from proceeding with seventy-five (75) percent of the normal labor and equipment force engaged in the current critical activity item for a period of at least five (5) hours per day toward completion of such operation or operations, and the crew is dismissed as a result thereof, it shall be a weather delay day.
- C. Material Shortages - Upon the submission of satisfactory proof to the Construction Manager by the Contractor, shortages of material may be acceptable as grounds for granting a time extension. In order that such proof may be satisfactory and acceptable to the Construction Manager, it must be demonstrated by the Contractor that the Contractor has made every effort to obtain such materials from all known sources within reasonable reach of the proposed Work. Only the physical shortage of material, caused by unusual circumstances, will be considered under these provisions as a cause for extension of time, and no consideration will be given to any claim that material could not be obtained at a reasonable, practical, or economical cost or price, unless it is shown to the satisfaction of the Construction Manager that such material could have been obtained only at exorbitant prices entirely out of line with current rates, taking into account the quantities involved and usual practices in obtaining such quantities. A time extension for shortage of material will not be considered for material ordered or

delivered late or whose availability is affected by virtue of the mishandling of procurement. The above provisions apply equally to equipment to be installed in the work.

6.3.4 Compensable Delays - Compensable delays in the prosecution or completion of the Work shall include delays that occur through no fault of the Contractor or its subcontractors and prevent the Contractor from proceeding with at least seventy-five (75) percent of the normal labor and equipment force for at least five (5) hours per day toward completion of the current critical activity item(s) on the latest favorably reviewed progress schedule due to the following cause(s):

- A. Delays due solely to the actions and/or inactions of the Owner.
- B. Delays due to differing site conditions as defined in Section 00700-7.2, **Differing Site Conditions**.
- C. Delays due to other Contractors employed by the Owner who interfere with the Contractor's prosecution of the Work as defined above.

6.3.5 Concurrent Delays - Concurrent delays are those delay periods when the prosecution of the Work is delayed during the same period of time due to causes from a combination of the delays defined in Sections 00700-6.3.2, Non-Excusable Delays, 00700-6.3.3, Excusable Delays, or 00700-6.3.4, Compensable Delays. During such concurrent delay periods, time extensions will be granted in accordance with Section 00700-6.4, **Time Extensions**; however, the Contractor will be granted a non-compensable time extension, and the Owner shall not assess its actual costs as defined in Section 00700-6.4.1, Non-Excusable Delays.

6.4 **Time Extensions**

6.4.1 Non-Excusable Delays - The Owner, at its sole option, may grant an extension to milestone or completion dates for non-excusable delays. If the Owner grants an extension of time for non-excusable delays, the Contractor agrees to pay the Owner's actual costs, including charges for engineering, inspection and administration incurred during the extension.

6.4.2 Excusable or Compensable Delays - If the Contractor is delayed in the performance of its work as defined in Sections 00700-6.3.3, Excusable Delays, or 00700-6.3.4, Compensable Delays, then milestone and Contract completion dates may be extended by the Owner for such time that, in the Owner's and Construction Manager's determination, the Contractor's completion dates will be delayed, provided that the Contractor strictly fulfills the following:

- A. The Contractor shall provide notification, in accordance with Paragraph 00700-6.3.1, Notice of Delays, and submit in writing a request for an extension of time to the Construction Manager stating at a minimum the probable cause of the delay and the number of days being requested. The time extension request shall be submitted in writing to the Owner.
- B. If requested by the Construction Manager, the Contractor shall promptly provide sufficient information to the Construction Manager to assess the cause or effect of the alleged delay, or to determine if other concurrent delays affected the work.

- C. Weather Delays. The Contractor will be granted a non-compensable time extension for weather caused delays, pursuant to Section 00700-6.3.3.B, Weather Delays, over and above an allowance as provided for in Section 00800-1.3, **Weather Days**. No time extensions for weather delays will be granted until the total number of weather days exceeds this allowance.

Should the Contractor fail to fulfill any of the foregoing, which are conditions precedent to the right to receive a time extension, the Contractor waives the right to receive a time extension.

During such extension of time, neither extra compensation for engineering, inspection and administration nor damages for delay will be charged to the Contractor. It is understood and agreed by the Contractor and Owner that time extensions due to excusable or compensable delays will be granted only if such delays involve controlling operations which would prevent completion of the whole Work within the specified Contract time.

Should the Contractor fail to complete the Work within the time specified in the Contract, as extended in accordance with this clause if appropriate, the Contractor shall pay to the Owner liquidated damages in accordance with Section 00700-6.5, **Liquidated Damages**.

6.4.3 **Indirect Overhead**

The Contractor shall be reimbursed for indirect overhead expenses for periods of time when the Work is delayed as defined in Section 00700-6.3.4, **Compensable Delays**. However, no reimbursement for indirect overhead shall be made for compensable delays which occur during a concurrent delay as defined in Section 00700-6.3.5, **Concurrent Delays**. As a condition precedent to any reimbursement, the Contractor must fulfill all conditions as provided in Section 00700-6.4.2 **Excusable or Compensable Delays**. No additional markup for overhead or profit shall be provided for such indirect overhead expenses.

Payment to the Contractor for indirect overhead expenses will be made only if the extended Contract period granted for the compensable delay(s) is required to complete the work following the depletion of the original Contract period and any time extensions granted other than compensable time extensions.

6.4.3.1 **Indirect Field Overhead** – For those allowable delay periods as defined in Section 00700-6.4.3, **Indirect Overhead**, the Contractor shall be reimbursed for its indirect field overhead based on:

- A. Actual invoice costs for on-site field offices and temporary utilities.
- B. Actual labor costs.
- C. Fair rental values acceptable to the Construction Manager for construction equipment idled due to the delay.

6.4.3.2 **Indirect Home Office Overhead** – For those allowable delay periods as defined in Section 00700-6.4.3, **Indirect Overhead**, the Contractor shall be reimbursed for its unabsorbed home office overhead based on the following formula:

Contract Bid Price (\$) _____ x 0.03 = Daily Home Office Overhead (\$/Day)
Contract Period (Days)

As it is impractical to determine the actual home office overhead, such reimbursement shall encompass full payment for any and all home office overhead expenses for such periods of time for the Contractor and all subcontractors. Distribution of the markup amount among the Contractor and all subcontractors and suppliers is the responsibility of the Contractor.

6.5 Liquidated Damages

- A. Owner and the Contractor recognize that time is of the essence of this Agreement and that the Owner will suffer financial loss if the Work is not completed within the time specified in Section 00800-1.1, **Time Allowed for Completion**, and required milestone work in Section 00800-1.2 herein, plus any extensions thereof allowed in accordance with Section 00700-6.4 of the General Conditions. It is hereby understood and agreed that it is and will be difficult and/or impossible to ascertain and determine the actual damage which the Owner will sustain in the event of and by reason of the Contractor's failure to fully perform the Work or to fully perform all of its contract obligations that have accrued by the time for completion as specified in Section 00800-1.1 herein and/or as specified for completion of any scheduled operations or works described in Section 00800-1.2. It is, therefore, agreed in accordance with California Government Code Section 53069.85 that the Contractor will forfeit and pay to the Owner liquidated damages in the amount set forth in Section 00800-1.2, **Damages for Delays**, per day for each and every calendar day that expires after the time for completion specified in 00800-1.1 herein and/or as specified for completion of any scheduled operations or works described in Section 00800-1.2 except as otherwise provided by extension of time pursuant to Section 00700-6.4 of the General Conditions. It is further understood and agreed in accordance with California Government Code Section 53069.85 that the liquidated damages sum specified in this provision is not manifestly unreasonable under the circumstances existing at the time this Contract was made, and that the Owner may deduct liquidated damages sums in accordance with this provision from any payments due or that may become due the Contractor.
- B. Liquidated damages will continue to accrue at the stated rate until substantial completion of the Work. Accrued liquidated damages may be deducted by the Owner from amounts due or that become due to the Contractor for performance of the Work. Liquidated damages may not be waived or reduced by the Owner unless expressly waived or reduced in writing by the Construction Manager.

6.6 Suspension of Work

6.6.1 If the Contractor fails to correct defective work as required by Section 00700-5.3, **Materials and Workmanship**, or fails to carry out the Work in accordance with the Contract Documents or any other applicable rules and regulations, the Owner, by a written order of the Owner's representative or signed personally by an agent specifically so empowered by the Owner, in writing, may order the Contractor to stop the work, in its entirety or any portion thereof. In the event of a suspension of only a portion of the work, the Contractor is obligated to perform the portion of the work not suspended. The Suspension of Work shall remain in effect until the condition or cause for such order has been eliminated. The Owner's concurrence that

the condition or cause has been eliminated will be provided to the Contractor in writing. This right of the Owner to stop and suspend the Work shall not give rise to any duty on the part of the Owner to exercise this right for the benefit of the Contractor or any other person or entity. All delays in the Work occasioned by such stoppage shall not relieve the Contractor of any duty to perform the Work or serve to extend the time for its completion. Any and all necessary corrective work done in order to comply with the Contract Documents shall be performed at no cost to the Owner.

6.6.2 In the event that a suspension of Work is ordered, as provided in this paragraph, the Contractor, at its expense, shall perform all work necessary to provide a safe, smooth, and unobstructed passageway through construction for use by public, pedestrian, and vehicular traffic, during the period of such use by suspension. Should the Contractor fail to perform the Work as specified, the Owner may perform such work and the cost thereof may be deducted from partial payments and/or final payment due the Contractor under the Contract.

6.6.3 The Owner shall also have authority to suspend the Work wholly or in part, for such period as the Owner may deem necessary, due to unsuitable weather, or to such other conditions as are considered unfavorable for the suitable prosecution of the Work. Such temporary suspension of the Work will be considered justification for time extensions to the Contract in an amount equal to the period of such suspension if such suspended work includes the current critical activity on the latest favorably reviewed progress schedule. The Contractor as directed by the Owner shall comply with the provisions in Section 00700-6.6.2, **Suspension of Work**, above. Such additional work shall be compensated as provided for in Section 00700-7.0, **CHANGES IN THE WORK**.

6.7 **Right to Terminate Contract**

If at any time the Contractor is determined to be in material breach of the Contract, notice thereof in writing will be served upon the Contractor and its sureties, and should the Contractor neglect or refuse to provide means for a satisfactory compliance with the Contract, as directed by the Construction Manager, within the time specified in such notice, the Owner or the Owner's Representative in such case shall have the authority to terminate the operation of the Contract. Upon such termination, the Contractor shall discontinue the Work, or such parts of it as the Owner may designate. Upon such termination, the Contractor's control shall terminate and thereupon the Owner or its fully authorized representative may take possession of all or any part of the Contractor's materials, tools, equipment, and appliances upon the premises and use the same for the purposes of completing the Work and hire such force and buy or rent such additional machinery, tools, appliances, and equipment, and buy such additional materials and supplies at the Contractor's expense as may be necessary for the proper conduct of the Work and for the completion thereof; or the Owner may employ other parties to carry the Contract to completion, employ the necessary workers, substitute other machinery or materials and purchase the materials contracted for, in such manner as the Owner may deem proper; or the Owner may annul and cancel the Contract and release the Work or any part thereof. Any excess of cost arising therefrom over and above the Contract Price will be charged against the Contractor and its sureties, who will be liable therefor.

In the event of such termination, all monies due the Contractor or retained under the terms of this Contract shall be held by the Owner; however, such holdings will not release the Contractor or its sureties from liability for failure to fulfill the Contract. Any excess cost over and above the Contract Amount incurred by the Owner arising from the termination of the operations of the

Contract and the completion of the Work by the Owner as above provided shall be paid for by the Contractor. The Contractor shall be entitled to credit against such excess costs and contract funds held by the Owner. Any contract funds remaining after all valid claims for completion of the Work have been paid, shall be paid to the Contractor sixty (60) days after completion of the Work.

If at any time before completion of the work under the Contract, it shall be determined by the Owner that it impossible, impractical, undesirable, or otherwise against the interests of the Owner to complete the work, or if the work shall be stopped by an injunction of a court of competent jurisdiction or by order of any competent authority, the Owner may, upon ten (10) days written notice to the Contractor, discontinue the work and terminate the Contract for its convenience. Upon service of such notice of termination, the Contractor shall discontinue the work in such manner, sequence, and at such times as the Construction Manager may direct. The Contractor shall have no claim for damages for such discontinuance or termination, nor any claim for anticipated profits on the work thus dispensed with, nor any other claim except for the work actually performed up to the time of discontinuance, including any extra work ordered by the Construction Manager to be done, nor for any claim for liquidated damages.

7.0 CHANGES IN THE WORK

7.1 Change Orders

7.1.1 Without invalidating the Contract and without notice to sureties or insurers, the Owner through the Construction Manager, may at any time or from time to time, order additions, deletions, or revisions in the Work; these will be authorized by Field Directive, Field Order, or Change Order. A Change Order will not be issued for a Field Directive unless the Construction Manager concurs with an appeal by the Contractor that such Field Directive is a change in the scope of the Contract. The Contractor shall comply promptly with the requirements for all Change Orders, Field Orders, or Field Directives. The work involved in Change Orders shall be executed under the applicable conditions and requirements of the Contract Documents. If any Field Order causes an increase or decrease in the Contract Amount or an extension or shortening of the Contract Time, an equitable adjustment will be made by issuing a Change Order. By the acceptance of a Change Order, the Contractor waives any claim for additional time, not included in the Change Order, for the work covered by that Change Order. Additional or extra work performed by the Contractor without written authorization of a Field Order or Change Order will not entitle the Contractor to an increase in the Contract Amount or an extension of the Contract Time.

7.1.2 Compensable extra work shall be that work required for the completed project, but not shown, detailed or specified in the Contract Documents and not constituting "incidental work" as defined in section 00700-1.4. Such work shall be governed by all applicable provisions of the Contract Documents. In giving instructions, the Construction Manager shall have authority to make minor changes in the Work, not involving extra cost, and not inconsistent with the purposes of the Work; but otherwise, except in an emergency endangering life or property, no extra work or change shall be made unless in pursuance of a written order by the Owner through the Construction Manager, and no claim for an addition to the Contract Amount and/or Contract Time shall be valid unless so ordered.

7.1.3 In case any change increases or decreases the work shown, the Contractor shall be paid for the work actually done at a mutually agreed upon adjustment to the Contract Price.

7.1.4 If the Contractor refuses to accept a Change Order, the Owner may issue it unilaterally. The Contractor shall comply with the requirements of the Change Order. The Owner shall provide for an equitable adjustment to the Contract Price and/or Contract Time, and compensate the Contractor accordingly. If the Contractor does not agree that the adjustment is equitable, it may submit a claim in accordance with Section 00700-7.3, Resolution of Disputes.

7.2 Differing Site Conditions

Pursuant to Public Contract Code Section 7104, the Contractor shall promptly, and before such conditions are disturbed, notify the Construction Manager in writing, of any:

- a. Material that the Contractor believes may be material that is hazardous waste, as defined in Section 25117 of the Health and Safety Code, that is required to be removed to a Class I, Class II, or Class III disposal site in accordance with provisions of existing law.
- b. Subsurface or latent physical conditions at the site differing from those indicated in the Contract Documents.
- c. Unknown physical conditions at the site of any unusual nature, differing materially from those ordinarily encountered and generally recognized as inherent in work of the character provided for in the Contract.

The Owner shall promptly investigate the conditions, and if it finds that the conditions do materially differ, or do involve hazardous waste, and cause a decrease or increase in the Contractor's cost of, or the time required for, performance of any part of the Work the Owner shall cause to be issued a change order under the procedures provided in Section 00700-7.1, Change Orders.

In the event that a dispute arises between the Owner and the Contractor whether the conditions materially differ, or involve hazardous waste, or cause a decrease or increase in the Contractor's cost of, or time required for, performance of any part of the work the Contractor shall not be excused from any scheduled completion date provided for by the Contract, but shall proceed with all work to be performed under the Contract. The Contractor shall retain any and all rights provided either by Contract or by law which pertain to the resolution of disputes and protests between the contracting parties, Section 00700-7.3, Resolution of Disputes.

No claim of the Contractor under this clause shall be allowed unless the Contractor has given the notice required.

7.3 Resolution of Disputes

It is the intent of this Contract that disputes regarding the Contract be resolved promptly and fairly between the Construction Manager and Contractor. However, it is recognized that some disputes will require detailed investigation and review by one or both parties before a determination and resolution can be reached. For the protection of the rights of both the

Contractor and Owner the following provisions are provided for the resolution of disputes which cannot be resolved by the Contractor and Construction Manager.

7.3.1 Notice – Either party shall provide verbal or written notice of disputed or potentially disputed work to the other parties’ attention prior to the commencement of and sufficiently in advance of performing the disputed work to allow both parties joint initial review of the disputed work. If there is disagreement subsequent to the initial review, the Contractor shall formally request a Contract Interpretation by the Construction Manager in accordance with 00700-1.6. If the Contractor disagrees with the Construction Manager's decision in Section 00700-1.6, **Contract Interpretation by the Construction Manager**, or in any case where the Contractor deems additional compensation or a time extension to the Contract Time is due the Contractor for work or materials not covered in the Contract or which the Construction Manager has not recognized as extra work, the Contractor shall notify the Construction Manager, in writing, of its intention to make claim. Notice pertaining to decisions provided in Section 00700-1.6, **Contract Interpretation by the Construction Manager**, or such other determinations by the Construction Manager shall be filed in writing to the Construction Manager within ten (10) days of receipt of such decision and prior to the commencement of such work. All other notices for extra work shall be filed in writing to the Construction Manager prior to the commencement of such work. Written notice shall use the words "Notice of Potential Claim". Such Notice of Potential Claim shall state the circumstances and the reasons for the claim, but need not state the amount.

Additionally, no claim for additional compensation or extension of time for a delay will be considered unless the provisions of Sections 00700-6.3, **Delays**, and 6.4, **Time Extensions**, are complied with. No claim filed after the date of final payment will be considered.

Unless notice is properly given, the Contractor shall not recover costs incurred by it as a result of the alleged extra work, changed work or other situation which had proper notice been given would have given rise to a right for additional compensation. The Contractor should understand that timely notice of potential claim is of great importance to the Construction Manager and Owner, and is not merely a formality. Such notice allows the Owner to consider preventative action, to monitor the Contractor's increased costs resulting from the situation, to marshal facts, and to plan its affairs. Such notice by the Contractor, and the fact that the Construction Manager has kept account of the work in question, shall not in any way be construed as proving the validity of the claim.

7.3.2 Response by Construction Manager - The Construction Manager shall review the “Notice of Potential Claim” and within ten (10) days of receipt of the notice shall respond to the Contractor in writing with its determination, or if it is necessary to extend this period, the Construction Manager shall notify the Contractor in writing as to when a decision will be provided.

7.3.3 Appeals to the Owner’s Representative - In the event the Contractor disagrees with any determination of the Construction Manager provided in accordance with Section 00700-7.3.2, **Response by Construction Manager**, the Contractor may, within ten (10) days of receipt of such determination, appeal the determination to the Owner’s Representative for review. The Owner’s Representative shall review the appeal and transmit the decision in writing to the Contractor within 30 days from the date of receipt of the appeal. Failure of the Contractor to appeal the determination of the Construction Manager within said ten (10) day period shall constitute a

waiver of the Contractor's right to thereafter assert claim resulting from such determination or decision.

In the event the Contractor disagrees with the determination of the Owner's Representative, the Contractor shall notify the Construction Manager, in writing within ten (10) days of receipt of such determination, of its intention to make claim in accordance with Section 00700-7.3.7, Resolution of Claims.

7.3.4 Records of Disputed Work - In proceeding with a disputed portion of the Work, the Contractor shall keep accurate records of all costs, including a summary of the hours and classification of equipment and labor utilized on the disputed work, as well as a summary of any materials or any specialized services which are used. Such information shall be submitted to the Construction Manager on a daily basis, receipt of which shall not be construed as an authorization for or acceptance of the disputed work.

7.3.5 Submission of Claim Costs - Within 30 days after the last cost of work for which the Contractor contends it is due additional compensation is incurred, but if costs are incurred over a span of more than 30 days, then within 15 days after the thirtieth day and every month thereafter, the Contractor shall submit to the Construction Manager, as best the Contractor is able, its costs incurred for the claimed matter. Claims shall be made in itemized detail and should the Construction Manager be dissatisfied with the format or detail of presentation, upon request for more or different information, the Contractor will promptly comply, to the satisfaction of the Construction Manager. If the additional costs are in any respect not knowable with

certainty, they shall be estimated as best can be done. The Construction Manager shall have the right to review the Contractor's records pertaining to a submitted claim. In case the claim is found to be just, it shall be allowed.

7.3.6 Claim Meetings - From time to time the Contractor may request or the Construction Manager may call a special meeting to discuss outstanding claims should it deem this a means of possible help in the resolution of the claim. The Contractor shall cooperate and attend prepared to discuss its claims, making available the personnel, subcontractors and suppliers necessary for resolution, and all documents which may reasonably be requested by the Construction Manager.

7.3.7 Resolution of Claims - Claims pertaining to this Agreement for three hundred and seventy-five thousand dollars (\$375,000) or less which cannot be resolved between the parties shall be resolved pursuant to the provisions of Public Contract Code commencing at Section 20104.

7.3.7.1 Claims Not Exceeding \$375,000 - Said Code sections provide in part that:

Under the law (starting at Public Contract Code Section 20104.2) construction claims of \$375,000.00 or less on local public agency construction contracts must be in writing and include the documents necessary to substantiate the claim. Claims must be filed on or before the date of final payment.

The Owner must respond in writing to any written claim of three hundred seventy-five thousand dollars (\$375,000) or less within 60 days (or, in the case of claims of less than fifty thousand dollars (\$50,000), within 45 days) of receipt of claim, or may request, in writing, within 30 days

of receipt of the claim, any additional documentation supporting the claim or relating to defenses to the claim the Owner may have against the claimant.

If additional information is thereafter required, it shall be requested and provided, pursuant to Public Contract Code Section 20104.2, upon mutual agreement of the Owner and the claimant.

The Owner's written response to the claim, as further documented, shall be submitted to the claimant within 30 days (or, for claims of less than \$50,000, within 15 days) after receipt of the further documentation, or within a period of time no greater than that taken by the claimant in producing the additional information or requested documentation, whichever is greater.

If the claimant disputes the Owner's written response (or if the Owner fails to respond within the time periods prescribed above) the claimant may notify the Owner, in writing, within 15 days of receipt of the Owner's response or within 15 days of the Owner's failure to respond within the times prescribed, respectively, and demand an informal settlement conference. The Owner must then schedule a settlement conference within 30 days.

Following the settlement conference, if the claim or any portion remains in dispute, the claimant may file a claim as required by the claims statute commencing at California Government Code Section 910. The time within which a Government Code claim must be filed is tolled from the time the claimant submits the Public Contract Code claim until the time when the claim is denied.

7.3.7.2 Claims Exceeding \$375,000 - Unless this Contract provides otherwise, all claims between the Owner and the Contractor that are not resolved between the parties and are not governed by Public Contract Code Section 20104 shall be resolved according to the procedures established in Public Contract Code Section 20104 with the following exceptions:

- a. The Owner must respond in writing to any written claim greater than three hundred seventy-five thousand dollars (\$375,000) within 60 days of receipt of the claim, or may request in writing, within 30 days of receipt of the claim, any additional documentation supporting the claim or relating to defenses to the claim the Owner may have against the claimant, or may advise the Contractor in writing within 30 days of receipt of the claim when the review and response to the claim will be furnished.
- b. The arbitration proceedings established in Public Contract Code Section 20104.4(b) and specified in Section 00700-7.3.7.3, Civil Action Proceedings, shall only apply if both the Owner and Contractor mutually agree to arbitration.

7.3.7.3 Civil Action Proceedings - If a civil action is filed to resolve the claim, then between 30 and 60 days after the filing of responsive pleadings, the court shall submit the matter to nonbinding mediation unless waived by the parties. The parties are given 15 days to select a disinterested third person as mediator. Mediation must commence within 30 days of submittal and conclude within 15 days of commencement unless the time is extended for good cause by the court.

If the matter remains in dispute, the case must be submitted to judicial arbitration pursuant to procedures set forth in the Code of Civil Procedure commencing at Section 1141.10. Discovery is permitted consistent with the rules pertaining to judicial arbitration.

Arbitrators shall be experienced in construction law.

A party who appeals an arbitration award and does not obtain a more favorable judgement shall pay the attorney's fees on appeal of the other party. The Owner must pay interest at the legal rate on any arbitration award or judgement, commencing on the date when suit was filed. Except as otherwise provided in the Contract, the Owner must pay the undisputed portions of any claims.

Should either party to this Contract bring legal action against the other, the case shall be handled by the Superior Court of the State of California in the County of Marin. The Agreement shall be construed and its performance enforced under California Law.

8.0 PAYMENT

8.1 Basis of Payment

8.1.1 General - The Contractor shall accept the compensation, as herein provided, as full payment for furnishing all labor, materials, tools, equipment, and incidentals necessary to the completed Work and for performing all work contemplated and embraced under the Contract; also for loss or damage arising from the nature of the Work, or from the action of the elements, or from any unforeseen difficulties which may be encountered during the prosecution of the Work, also for all expenses incurred in consequence of the suspension or discontinuance of the Work as herein specified; and for completing the Work according to the Contract Documents. Neither the payment of any estimate nor of any retained percentage shall relieve the Contractor of any obligation to make good any defective work or material.

No compensation will be made in case of loss of anticipated profits. Increased or decreased work involving supplemental agreements will be paid for as provided in such agreements.

Full compensation for conforming to all of the provisions of the Contract Documents shall be considered as included in the prices paid for the various Contract items of work and no additional compensation will be allowed therefor.

8.1.2 Payment for Patents and Patent Infringement - All fees or claims for any patented invention, article, or arrangement that may be used upon, or in, any manner connected with the performance of the Work or any part thereof shall be included in the price bid for doing the work, and the Contractor and its sureties shall defend, protect, and hold the Owner, the Construction Manager, and Design Consultants, together with all their officials, officers, volunteers, agents, and employees harmless from and any and all suits and claims including claims for attorneys fees, expert's fees and costs brought or made by the holder of any invention or patent, or on account of any patented or unpatented invention, process, article, or appliance manufactured for or used in the performance of the Contract, including its use by the Owner, unless otherwise specifically stipulated in the Contract. Before final payment is made on the Contract, the Contractor shall furnish an affidavit to the Owner regarding patent rights for the Project. The affidavit shall state that all fees and payments due as a result of the work incorporated into the Project or methods utilized during construction have been paid in full. The Contractor shall certify in the affidavit that no other fees or claims exist for work in this Project.

8.1.3 Payment of Taxes - The Contractor shall pay and shall assume exclusive liability for all taxes levied or assessed on or in connection with its performance of this Contract, whether before or after acceptance of the work, including, but not limited to, State and local sales and use taxes, Federal and State payroll taxes or assessments, and excise taxes, including any

taxes or assessments levied or increased during the performance period of the work. No separate allowance will be made therefor, and all costs in connection therewith shall be included in the total amount of the Contract price.

8.2 **Partial Payments**

8.2.1 **General** - In consideration of the faithful performance of the Work prosecuted in accordance with the Contract Documents, the Owner will pay the Contractor for all such work installed on the basis of unit prices and/or percentage completion of lump sum Bid Items.

Payments will be made by the Owner to the Contractor on estimates duly certified and approved by the Construction Manager, based on the Lump Sum or unit price value of equipment installed and tested, labor and materials incorporated into said permanent work by the Contractor during the preceding month, and acceptable materials and equipment on hand (materials and equipment furnished and delivered to the site by the Contractor and not yet incorporated into the work accompanied by an approved invoice). Payments will not be made for temporary construction unless specifically provided for in the Contract Documents.

Partial payments will be made monthly based on work accomplished as of a day mutually agreed to by the Owner and the Contractor.

The Contractor shall submit a completed and signed progress payment request form with its estimate of the work completed during the prior month and the work completed to date in a format corresponding to the unit price schedule and accepted cost breakdown. Additionally, the Contractor shall submit a detailed statement of the Contractor's request for payment of acceptable materials and equipment on hand in compliance with Section 00700-8.2.2, **Partial Payments - Inclusion of Materials on Hand**. Each payment request shall list each Change Order executed prior to date of submission, including the Change Order Number.

Upon receipt of Contractor's requests for payment, the Owner shall act in accordance with the following:

- (a) The Construction Manager shall review the submitted estimates, as soon as practicable after receipt for the purpose of determining that the estimates are a proper request for payment, and shall prepare a certified estimate of the total amount of work done and acceptable materials and equipment on hand.
- (b) Any request for payment determined not to be a proper payment request suitable for payment shall be returned to the Contractor as soon as practicable, but not later than seven (7) days after receipt. A request for payment returned pursuant to this paragraph shall be accompanied by a document setting forth in writing the reasons why the request for payment is not proper.
- (c) The number of days available to the Owner to make a payment without incurring interest pursuant to this section shall be reduced by the number of days by which the Owner exceeds the seven (7) day return requirement set forth in subdivision (b) above.

If requested, the Contractor shall provide such additional data as may be reasonably required to support the partial payment request. The Construction Manager will be available to meet and discuss the partial payment request prior to its resubmittal(s). When the Contractor's estimate

of amount earned conforms with the Construction Manager's evaluation, the Contractor shall submit to the Construction Manager a properly completed and signed progress payment request. The Construction Manager will submit the recommended progress payment request for the Owner's approval and processing. Payment will be made by the Owner to the Contractor in accordance with Owner's normal accounts payable procedures; the Owner shall retain amounts in accordance with Section 00700-8.3, **Right to Withhold Amounts**.

No such estimate or payment shall be required to be made, when in the judgement of the Construction Manager, the Work is not proceeding in accordance with the provisions of the Contract, or when in the Construction Manager's judgement the total value of the Work done since the last estimate amounts to less than One Thousand Dollars (\$1,000).

Subject to the provisions of this section, the Owner shall pay the Contractor within thirty (30) days after receipt of undisputed and properly submitted requests for payment from the Contractor. In accordance with Public Contract Code Section 20104.50, if the Owner fails to pay an undisputed request for payment within the allotted thirty (30) days, the Owner shall pay interest to the Contractor equivalent to the legal rate set forth in subdivision (a) of Section 685.010 of the Code of Civil Procedure.

Each progress payment request and the final payment request shall be deemed "proper" only if it is submitted on the form approved by the Owner, with all of the requested information completely and accurately provided by the Contractor and such completed progress payment request form or final payment request form is accompanied by: (i) certified payrolls of the Contractor and all Subcontractors, of any tier, for laborers performing any portion of the Work for which a progress payment or final payment is requested; (ii) duly completed and executed Conditional Waiver and Release Upon Progress Payment or Final Payment forms in accordance with California Civil Code §3262 for all Subcontractors of any tier, and Material Suppliers covering the progress payment or final payment requested; (iii) duly completed and executed Unconditional Waiver and Release Upon Progress Payment forms in accordance with California Civil Code §3262 for all Subcontractors of any tier, and Material Suppliers covering the Progress Payment received by the Contractor under the prior progress payment request.

8.2.2 Partial Payments - Inclusion of Materials on Hand - Materials, as used herein, shall be considered to be those items which are fabricated and manufactured material and equipment. Only those materials for which the Contractor can transfer clear title to the Owner will be qualified for partial payment. The Contractor may request payment of seventy-five (75) percent of the actual net cost of these materials. The request for partial payment will be subject to retention as provided elsewhere in the Contract Documents.

To receive partial payment for materials and equipment not incorporated in the Work, it shall be necessary for the Contractor to submit to the Construction Manager a list of such materials, at least seven (7) days prior to submitting the monthly estimate of amount earned for work completed. At the Construction Manager's sole discretion, it will approve items for which partial payment is to be made subject to the following:

- a. Equipment and materials will only be eligible if given conditional or final acceptance by the Design Consultant and are in apparent compliance with favorably reviewed shop drawings.

- b. Only equipment or materials which have received favorable review of shop drawings will qualify. The Operation and Maintenance Manuals for equipment must be submitted prior to payment for stored materials.
- c. Eligible equipment or materials must be delivered and properly stored, protected, and maintained in a manner favorably reviewed by the Construction Manager, at the job site.
- d. The Contractor's actual net cost for the materials must be supported by paid invoices of suppliers, or other documentation requested by the Construction Manager.
- e. Materials or equipment delivered to the Site less than thirty (30) days prior to their scheduled incorporation in the Work shall not qualify.
- f. Final payment shall be made only for materials actually incorporated in the Work and, upon acceptance of the Work, all materials remaining for which advance payments had been made shall revert to the Contractor, unless otherwise agreed, and partial payments made for these items shall be deducted from the final payment for the Work.
- g. Partial payments for materials and equipment on hand shall not be deemed to be final payment for the material nor relieve the Contractor of its obligations under the Contract.
- h. Partial payments for materials and equipment on hand shall not be construed or considered as acceptance of any portion of the Work.
- i. Partial payments for materials and equipment on hand shall be subject to retention in accordance with Section 00700-8.3, **Right to Withhold Amounts**.

8.2.3 **Effect of Payment** – Payment will be made by Owner based on the Construction Manager’s observations at the site and the data comprising the progress payment request. Payment will not be a representation that the Owner has:

- (a) made exhaustive or continuous on-site inspections to check the quality or quantity of Work;
- (b) reviewed construction means, methods, techniques, sequences or procedures;
- (c) reviewed copies of requisitions received from subcontractors and material suppliers and other data requested by Owner to substantiate Contractor’s right to payment;
- (d) made examination to ascertain how or for what purpose Contractor has used money previously paid on account of the Contract Sum; or
- (e) accepted all or part of the Work.

8.2.4 **Cash Flow Projection** – A cash flow projection covering the entire construction period shall be included with the monthly contract earnings estimate report. The time increment shall be monthly and shall be revised monthly to show actual earnings and changes to projected cash flows. If there is a difference in the percent complete of the Work as measured by the CPM schedule and the percent complete of the Work as measured by the monthly contract earnings estimate, the Contractor shall explain the reason for the difference.

8.3 **Right to Withhold Amounts**

8.3.1 **Retention** - The Owner will withhold from each of the partial payments and retain as part security, five (5) percent of the amount earned until the final payment.

8.3.2 **Other Withholds** - In addition to the amount which the Owner may otherwise retain under the Contract, the Owner may withhold a sufficient amount or amounts of any payment or payments otherwise due the Contractor, as in its judgment may be necessary to cover:

- a. For defective work not remedied.
- b. A reasonable doubt that the Contract can be completed for the balance then unpaid.
- c. Damage to another contractor or third party, or to property.
- d. Failure of the Contractor to maintain Record Documents current.
- e. Cost of insurance arranged by the Owner due to cancellation or reduction of the Contractor's insurance.
- f. Failure to submit, revise, resubmit or otherwise conform to the requirements herein for preparing and maintaining a construction schedule.
- g. Failure to make proper submissions, as specified herein.
- h. Payments due the Owner from the Contractor.
- i. The Contractor's neglect or unsatisfactory prosecution of the Work including additional engineering and administrative costs related to construction and/or shop drawing errors and the failure to clean up.
- j. Provisions of law that enable or require the Owner to withhold such payments in whole or in part.
- k. Stop Notice claims filed by Contractor's subcontractors, of any tier, or its material suppliers.
- l. Failure of Contractor to submit Operation and Maintenance Manuals.

When the above reasons for withhold amounts are removed, payment will be made to the Contractor for amount withheld because of them.

8.4 **Security Substitution for Withholds**

For any retention of amount earned by the Contractor under Sections 00700-8.2, **Partial Payments**, or 00700-8.7, **Final Inspection and Payment**, the Contractor may substitute securities as provided in Section 22300 of the Public Contract Code, as amended, which state in part as follows:

"Provisions shall be included in any invitation for bid and in any contract documents to permit the substitution of securities for any moneys withheld by a public agency to ensure performance under a contract, provided that substitution of securities provisions shall not be required where federal regulations or policies, or both, do not allow the substitution of securities. At the request and expense of the contractor, securities equivalent to the amount withheld shall be deposited with the public agency, or with a state or federally chartered bank as the escrow agent, who shall then pay those monies to the contractor. Upon satisfactory completion of the contract, the securities shall be returned to the contractor."

Alternatively, the contractor may request and the Owner shall make payment of retentions earned directly to the escrow agent at the expense of the contractor. At the expense of the contractor, the contractor may direct the investment of the payments into securities and the contractor shall receive the interest earned on the investments upon the same terms provided for in this section for securities deposited by the contractor. Upon satisfactory completion of the contract, the contractor shall receive from the escrow agent all securities, interest and payments received by the escrow agent from the Owner, pursuant to the terms of this section. The contractor shall pay to each subcontractor, not later than 20 days of receipt of the payment, the respective amount of interest earned, net of costs attributed to retention withheld from each subcontractor, on the amount of retention withheld to insure the performance of the contractor."

"The contractor shall be the beneficial owner of any securities substituted for money withheld and shall receive any interest thereon."

Securities eligible for investment under Section 22300 shall be limited to those listed in Section 16430 of the Government Code and to bank or savings and loan certificates of deposit, interest-bearing demand deposit accounts, standby letters of credit, or any other security mutually agreed to by the Contractor and the Owner.

The escrow agreement used hereunder shall be null, void, and unenforceable unless it is substantially similar to the form in Section 00630, **ESCROW AGREEMENT FOR SECURITY DEPOSITS IN LIEU OF RETENTION**.

8.5 **Warranty of Title**

No material, supplies, or equipment for the Work under this Contract shall be purchased subject to any chattel mortgage, security agreement, or under a conditional sale or other agreement by which an interest therein or any part thereof is retained by the seller or supplier. The Contractor warrants good title to all material, supplies, and equipment installed or incorporated in the work and agrees upon completion of all work to deliver the premises, together with all improvements and appurtenances constructed or placed thereon by the Contractor, to the Owner free from any claims, liens, security interests, or charges. The Contractor further agrees that neither the Contractor nor any person, firm, or corporation furnishing any materials or labor for any work covered by this Contract shall have any right to a lien upon the premises or any improvement or appurtenances thereon, provided that this shall not preclude the Contractor from installing metering devices and other equipment of utility companies or of municipalities, the title of which is commonly retained by the utility company or the municipality. In the event of the installation of any such metering device or equipment, the Contractor shall advise the Owner as to the legal Owner thereof.

Nothing contained in this paragraph, however, shall defeat or impair the right of such persons furnishing materials or labor under any bond given by the Contractor for their protection or any rights under any law permitting such persons to look to funds due the Contractor in the hands of the Owner. The provisions of this Paragraph shall be inserted in all subcontracts and material contracts, and notice of its provisions shall be given to all persons furnishing materials for the work when no formal Contract is entered into for such materials.

8.6 Substantial Completion

When the Contractor considers that the Work is substantially complete, the Contractor shall notify the Construction Manager in writing. Upon receipt of the notification, the Construction Manager, the Owner, the Design Consultant and/or their authorized representatives will make inspection, to determine if the Work and administrative requirements are sufficiently complete in accordance with the Contract Documents so the Owner can occupy or utilize the Work for its intended use. If items are found which prevent such use or occupancy, the Construction Manager shall notify the Contractor in writing of such items by issuing a Corrective Work Item List.

Upon the completion of such corrective work, the Contractor shall so notify the Construction Manager in writing. The Construction Manager, the Owner and/or the Design Consultant shall inspect the Work to determine its acceptability for Substantial Completion and for determination of other items which do not meet the terms of the Contract. Upon verification that the Work is substantially complete the Construction Manager shall prepare a Certificate of Substantial Completion and the Punch List. The Certificate shall establish the date of Substantial Completion and the responsibilities of the Owner and Contractor for security, maintenance, heat, utilities, damage to the Work and insurance, commencement of warranties required by the Contract Documents, and shall fix the time, not to exceed 60 days, within which the Contractor shall finish all items on the Punch List or remaining work or administrative requirements accompanying the Certificate. When the preceding provisions have been approved by both the Owner and the Contractor, they shall sign the Certificate to acknowledge their written acceptance of the responsibilities assigned to them in such Certificate. By such acknowledgment, the Owner has the right to retain withheld monies due the Contractor to pay the Owner's actual costs including, but not limited to, charges for engineering, inspection and administration incurred due to the failure to complete the Punch List within the time period provided in the Certificate of Substantial Completion, which costs the Owner may deduct from amounts due or that may become due the Contractor under the Contract.

8.7 Early Occupancy

8.7.1 The District will take over occupancy as the Contractor substantially completes each sewer including all preparations necessary for District's occupancy or use.

8.7.2 Certificates of Substantial Completion will be executed for each sewer prior to District occupancy. Such certificate of Substantial Completion will describe the portion of the Work to be occupied by District, items that may be incomplete or defective, date of occupancy by District, and other information required by District and Contractor.

8.7.3 After District occupancy, allow access for District's personnel, access for others authorized by District, and District operation of equipment and systems.

8.7.4 Following Occupancy, District will:

- a. Pay for power to operate equipment and systems.
- b. Repair damage caused by District's occupancy, which is not a result of the Contractor's work.

8.7.5 The guarantee correction period for portions of the Work occupied or partially utilized by District shall commence with date of Substantial Completion for that portion of the Work and acceptance for use by District. Progress payment withholdings for portions of the Work occupied by District will not be released until final acceptance of the total Work.

8.7.6 Prior to such occupancy or use, the Contractor shall enter into agreement with District indicating work that remains to be performed in occupied areas.

8.7.7 When District's use of occupied facilities reveals defective work, the Contractor shall correct defects.

8.8 **Final Inspection and Payment**

Upon completion of the Work, including all items on the Punch List, and upon completion of final cleaning, the Contractor shall so notify the Construction Manager in writing. Upon receipt of the notification, the Construction Manager, the Owner and/or their authorized representatives will make the final inspection, to determine the actual status of the Work in accordance with the terms of the Contract. If materials, equipment, workmanship or administrative requirements are found which do not meet the terms of the Contract, the Construction Manager shall prepare a Final Inspection List of such items and submit it to the Contractor. Following completion of the work to correct all items in the Final Inspection List the Contractor shall notify the Construction Manager. The Construction Manager shall, in turn, notify the Owner that the Work has been completed in accordance with the Contract. Final determination of the acceptability of the Work shall be made by the Owner. After completion of the work, but prior to its acceptance by the Owner, the last partial payment will be made to the Contractor in accordance with Section 00700-8.2, **Partial Payments**.

After receipt of the last partial payment, but prior to acceptance of the Work by the Owner, the Contractor shall send a letter to the Construction Manager. The letter, pursuant to California Public Contract Code Section 7100, shall state that acceptance of the final payment described below shall operate as and shall be, a release to the Owner, the Construction Manager, the Design Consultant, and their duly authorized agents, from all claim of and/or liability to the Contract arising by virtue of the Contract related to undisputed contract amounts. Disputed Contract claims in stated amounts previously filed as provided in Section 00700-7.3, **Resolution of Disputes**, may be specifically excluded by the Contractor from the operation of the release.

Following receipt of all required submittals and the Construction Manager's written statement that construction is complete and recommendation that the Owner accept the project, the Owner will take formal action on acceptance.

Within ten (10) days of the acceptance by the Owner of the completed work embraced in the Contract, the Owner will cause to be recorded in the office of the County Recorder a Notice of Completion.

The final payment shall not be due and payable until the expiration of thirty-five (35) days from the date of recording the Notice of Completion by the Owner.

The Owner will pay the Contractor in lawful money such sums of money as may be due the Contractor including all sums retained but excluding such sums as have previously been paid the Contractor and as may be needed to cover outstanding stop notices. This payment will constitute the final payment to the Contractor under this Contract.

In the event of a dispute between the Owner and the Contractor, the Owner may in accordance with Public Contract Code Section 7107 withhold from the final payment an amount of 150 percent of the disputed amount.

***** END OF SECTION *****

SECTION 00800

SUPPLEMENTARY GENERAL CONDITIONS

1.0 MODIFICATIONS TO THE GENERAL CONDITIONS

1.1 Time Allowed for Completion

In accordance with the provisions of Section 00700-6.2, **Contract Time**, substantial completion of this project shall be completed within one hundred twenty (120) consecutive calendar days from the date established in the Notice to Proceed for the commencement of Contract Time.

1.2 Damages for Delays

In accordance with the provisions of Section 00700-6.5, **Liquidated Damages**, for the period of time that any portion of the work remains unfinished after the time fixed for an interim milestone and/or Substantial Completion in Section 00800-1.1, **Time Allowed for Completion**, as modified by extensions of time granted by the Owner, it is understood and agreed by the Contractor and the Owner that the Contractor shall pay the Owner \$500 per day damages.

1.3 Weather Days

In accordance with the provisions of Paragraph 00700-6.4.2.C, Weather Delays, an allowance of ten (10) working days of weather caused delay have been included in the time allowed for completion. This allowance represents a reasonable assessment of anticipated lost working days based on historical weather patterns. These weather days shall be included in the Contractor's schedule.

1.4 Contract Administration

The following project representatives are hereby designated by the Owner:

- A. Name of Owner Representative: Tony Rubio, District Manager,
Sanitary District No. 5
- B. Name of Design Consultant: Nute Engineering
- C. Name of Construction Manager: To Be Named by District

All communications to and from the Contractor shall be routed through the Construction Manager. Wherever the Contract Documents indicate that the Contractor shall contact or notify the Engineer, Architect, Design Consultants, Soils Engineer, Structural Engineer, etc., the Contractor shall route such communication through the Construction Manager except when otherwise explicitly approved by the Construction Manager.

2.0 LIABILITY AND INSURANCE

2.1 Insurance

Within ten (10) days after notice of award of the Contract, the Contractor shall promptly obtain, at its own expense, all the insurance required by Section 00800-2.0, **LIABILITY AND INSURANCE**, and submit coverage verification for approval by the Owner prior to the Owner's execution of the Contract.

The Notice to Proceed with the Work under this Contract will not be issued, and the Contractor shall not commence work, until such insurance has been approved by the Owner. Such insurance shall remain in full force and effect at all times during the prosecution of the Work and until the final completion and acceptance thereof. In addition, the Commercial General Liability insurance shall be maintained for a minimum of five (5) years after final completion and acceptance of the Work. The Notice to Proceed does not relieve the Contractor of the duty to obtain such insurance as required herein.

The Contractor shall not allow any subcontractor to commence work on its subcontract until all similar insurance required of the subcontractor, except Builder's Risk Insurance, has been obtained and verified by the Contractor and submitted to the Construction Manager for the Owner's review and records. Subcontractors shall furnish original certificates and required endorsements as verification of insurance coverage. The insurance liability limits specified in Section 00800-2.1.1. b(2), **LIABILITY AND INSURANCE**, shall also apply for all subcontractors listed in Section 00430, **DESIGNATION OF SUBCONTRACTORS**. The Contractor shall designate the required insurance liability limits for all other subcontractors.

Companies writing the insurance under this article shall be licensed to do business in the State of California or be permitted to do business under the Surplus Line Law of the State of California. Insurance is to be placed with insurers with a current A.M. Best's rating of no less than A:VII.

Each insurance policy required by this contract shall be endorsed to state that coverage shall not be suspended, voided, canceled by either party, reduced in coverage or in limits except after thirty (30) days prior written notice by certified mail, return receipt requested, has been given to the Owner.

Contractor shall include all costs for insurance in its bids.

Nothing contained in these insurance requirements is to be construed as limiting the extent of the Contractor's responsibility for payment of damages resulting from its operations under this Contract. For any claims related to this project, the Contractor's insurance coverage shall be primary insurance as respects the Owner, the Design Consultants and the Construction Manager, and their officers, officials, employees, agents and volunteers. Any insurance or self-insurance maintained by the Owner, its officers, officials, employees, agents or volunteers shall be in excess of the Contractor's insurance and shall not contribute with it.

Any failure of the Contractor to comply with reporting or other provisions of the policies including breaches of warranties shall not affect coverage provided to the Owner, the Design Consultants and the Construction Manager and their officers, officials, employees, agents or volunteers.

The Contractor shall take out, pay for, and maintain throughout the duration of this Contract and for such additional periods as more specifically required herein the following insurance against claims for injuries to persons or damages to property which may arise from or in connection with the performance of the work hereunder by the Contractor, the Contractor's agents, representatives, employees or subcontractors.

2.1.1 Commercial General Liability and Automobile Liability Insurance - This insurance shall protect the Contractor from claims for bodily injury, personal injury and property damage which may arise because of the nature of the work or from operations under this Contract. The Commercial General Liability Insurance shall be maintained for five (5) years after final completion and shall provide coverage on an occurrence basis.

- a. Additional Insureds - The Commercial General Liability and Automobile Policies of insurance shall include as additional insureds or be endorsed to contain the following provisions the "entities" listed below and each of their partners, officers, officials, employees, agents and volunteers are to be covered as insureds as respects: liability arising out of activities performed by or on behalf of the Contractor; products and completed operations of the Contractor; premises owned, occupied or used by the Contractor and or automobiles owned, leased, hired or borrowed by the Contractor. The coverage shall contain no special limitation on the scope of protection afforded to the "entities" and each of their partners, officers, officials, employees, agents and volunteers and coverage provided to such additional insured. This policy shall provide coverage to each of the said insureds with respect to said work. Said policy shall provide primary coverage to the full limit of liability stated in the declarations.

Sanitary District No. 5
1120 Mar West, Ste. E
Tiburon, CA 94920

Town of Tiburon
1505 Tiburon Blvd.
Tiburon, CA 94920

Nute Engineering
907 Mission Avenue
San Rafael, CA 94901

City of Belvedere
450 San Rafael Avenue
Belvedere, CA 94920

- b.(1) Amount of Coverage (General Contractor)- The bodily injury, personal injury and property damage liability of the Commercial General Liability insurance shall provide coverage in the following limits of liability: \$3,000,000 on account of any one occurrence for bodily injury and property damage, \$3,000,000 personal and advertising injury limit with an annual general aggregate limit of not less than \$3,000,000, and \$3,000,000 products and completed operations aggregate, combined single limit. The Automobile Liability insurance policy shall provide minimum limits of \$3,000,000 per accident for bodily injury and property damage and \$3,000,000 policy aggregate arising out of the ownership, maintenance, or use of any owned or non-owned vehicles.

- b.(2) Amount of Coverage (SUBCONTRACTORS LISTED IN SECTION 00430) - The bodily injury, personal injury and property damage liability of the Commercial General Liability insurance shall provide coverage in the following limits of liability: \$1,000,000 on account of any one occurrence for bodily injury and property damage, \$1,000,000 personal and advertising injury limit with an annual general aggregate limit of not less than \$1,000,000, and \$1,000,000 products and completed operations aggregate, combined single limit. The Automobile Liability insurance policy shall provide minimum limits of \$1,000,000 per accident and \$1,000,000 policy aggregate arising out of the ownership, maintenance, or use of any owned or non-owned vehicles.

- c. Subcontractors – The bodily injury and property damage liability insurance shall not be deemed to require the Contractor to have its subcontractors named as insureds in the Contractor's policy, but the policy shall protect the Contractor from contingent liability which may arise from operations of its subcontractors.
- d. Included Coverage - The above Commercial General Liability insurance shall also include the following coverages:
 - Premises – Operations
 - Independent Contractors
 - Products - Completed Operations
 - Personal Injury - (False Arrest, Libel, Wrongful Eviction, etc.)
 - Advertising Injury
 - Broad Form Property Damage Including, Completed Operations
 - Separation of Insureds/Cross-Liability Provision
 - Duty to Defend all Insureds
 - Deletion of any Limitation on Coverage for Bodily Injury or Property Damage Arising out of Subsidence or Soil or Earth Movement
 - Separate Aggregate - A provision that the annual general aggregate and the products and completed operations annual aggregate shall apply separately to each project for which Contractor provides services away from premises owned by or rented to Contractor.
 - XCU - (Explosion, Collapse, Underground Damage) is applicable to operations performed by the Contractor or its subcontractors.
 - Blanket Contractual Liability
- e. Umbrella Policy - Contractor may use an umbrella or excess policy to meet the limits requirement of Section 2.1.1.b(1). However, any such umbrella/excess policy must be approved by the Owner and maintain a A.M. Best Rating of no less than A:VII.

2.1.2 Workers' Compensation Insurance - In accordance with the provisions of Article 5, Chapter 1, Part 7, Division 2 (commencing with Section 1860) and Chapter 4, Part 1, Division 4 (commencing with Section 3700) of the Labor Code of the State of California, the Contractor is required to secure the payment of compensation to its employees and for that purpose obtain and keep in effect adequate Workers' Compensation Insurance. If the Contractor, in the sole discretion of the Owner, satisfies the Owner of the responsibility and capacity under the applicable Workers' Compensation Laws, if any, to act as self-insurer, the Contractor may so act, and in such case, the insurance required by this paragraph need not be provided.

The Contractor is advised of the provisions of Section 3700 of the Labor Code, which require every employer to be insured against liability for Workers' Compensation or to undertake self-insurance in accordance with the provisions of that code, and shall comply with such provisions and have

Employers' Liability limits of \$1,000,000 per accident and per employee, and in the aggregate for injury by disease, before commencing the performance of the work of this Contract.

Before the Notice to Proceed with the Work under this Contract is issued, the Contractor shall submit written evidence that the Contractor has obtained for the period of the Contract Workers' Compensation and Employer's Liability Insurance as required for all persons whom it employs or may employ in carrying out the work under this Contract. Such evidence of coverage shall be accompanied by an endorsement from the insurer agreeing to waive all rights of subrogation against the Owner, its officers, officials, employees, agents and volunteers, the Design Consultants, the

Construction Manager and their agents, consultants and employees which might arise by reason of any payment under the policy. This insurance shall be in accordance with the requirements of the most current and applicable State Workers' Compensation Insurance Laws.

2.1.3 Builder's Risk Insurance – Not Required.

2.1.4 Contractor's Pollution Legal Liability – Not required.

2.1.5 Proof of Coverage - Before the Notice to Proceed with the Work under this Contract is issued, the Contractor shall furnish the Owner with certificate(s) evidencing issuance of all insurance mentioned herein, copies of the policy declaration or information page(s) and additional insured endorsements. The certificate(s) and endorsements for each insurance policy are to be signed by a person authorized by that insurer to bind coverage on its behalf. The endorsements are to be on forms A-1 and B-1 as included in Section 00650, **GENERAL LIABILITY ENDORSEMENT**, and Section 00651, **AUTO LIABILITY ENDORSEMENT**, or equivalent endorsement forms acceptable to the Owner. The certificate(s), policy declaration or information page(s), and endorsements are to be received and approved by the Owner before work commences. Except for the waiver of subrogation rights endorsements, as required under Sections 00800-2.1.2 and 00800-2.1.3, no other endorsements are required for Workers Compensation or Builder's Risk Insurance. Such certificates of insurance shall provide that the insurance policy shall be endorsed to state that coverage shall not be suspended, voided, cancelled by either party, reduced in coverage or limits except after thirty (30) days prior written notice by certified mail, return receipt requested, has been given to the Owner. Contractor shall also provide certificate(s) evidencing renewals of all insurance required herein, at least thirty (30) days prior to the expiration date of any such insurance.

Any deductibles or self-insured retentions must be declared to and approved by the Owner. At the option of the Owner, either: the insurer shall reduce or eliminate such deductibles or self-insured retentions as respects the Owner, the Design Consultants and the Construction Manager and their officers, officials, employees, agents and volunteers; or the Contractor shall procure a bond guaranteeing payment of losses and related investigations, claim administration and defense expenses.

In the event of the breach of any provision of this paragraph, or in the event of any notices received which indicates any required insurance coverage will be diminished or canceled, Owner, at its option, may, notwithstanding any other provisions of this Agreement to the contrary, immediately declare a material breach of this Agreement and suspend all further work pursuant to this Agreement.

2.1.6 Indemnification

- A. Contractor shall indemnify, defend with counsel acceptable to Owner and hold harmless to the full extent permitted by law, Sanitary District No. 5, Nute Engineering, Beecher Engineering, the Town of Tiburon, the County of Marin, and their officers, officials, employees, agents and volunteers, (collectively “the Indemnified Parties”), from and against any and all liability, loss, damage, claims, expenses and costs (including, without limitation, attorney fees and costs and fees of litigation) (collectively, “Liability”) of every nature arising out of or in connection with Contractor’s performance of the Work or its failure to comply with any of its obligations contained in this Agreement, except such Liability caused by the active negligence, sole negligence or willful misconduct of the Indemnified Parties. Such indemnification by the Contractor shall include, but not be limited to, the following:
1. Liability or claims resulting directly or indirectly from the negligence or carelessness of the Contractor, its subcontractors, employees, or agents in the performance of the Work, or in guarding or maintaining the same, or from any improper materials, implements, or appliances used in its construction, or by or on account of any act or omission of the Contractor, its employees, or agents;
 2. Liability or claims arising directly or indirectly from bodily injury, occupational sickness or disease, or death of the Contractor’s, or Supplier’s own employees, or agents engaged in the Work resulting in actions brought against the Indemnified Parties;
 3. Liability or claims arising directly or indirectly from or based on the violation of any Laws or Regulations, whether by the Contractor, its subcontractors, employees, or agents;
 4. Liability or claims arising directly or indirectly from the use or manufacture by the Contractor, its subcontractors, employees, or agents in the performance of this Agreement of any copyrighted or uncopyrighted composition, secret process, patented or unpatented invention, article, or appliance, unless otherwise specified stipulated in this Agreement.
 5. Liability or claims arising directly or indirectly from the breach of any warranties, whether express or implied, made to the Owner or any other parties by the Contractor, its subcontractors, employees, or agents;
 6. Liability or claims arising directly or indirectly from the willful misconduct of the Contractor, its subcontractors, employees, or agents;
 7. Liability or claims arising directly or indirectly from any breach of the obligations assumed in this Agreement by the Contractor;
 8. Liability or claims arising directly or indirectly from, relating to, or resulting from a hazardous condition created by the Contractor, Subcontractors, Suppliers, or any of their employees or agents, and;
 9. Liability or claims arising directly, or indirectly, or consequentially out of any action, legal or equitable, brought against the Indemnified Parties, the Engineer, their consultants, subconsultants, and the officers, directors, employees, agents and volunteers of each or any of them, to the extent caused by the Contractor’s use of any premises acquired by permits, rights of way, or easements, the Site, or any land or area contiguous hereto or its performance of the Work thereon.
 10. Liability arising directly or indirectly from exposure to hazards in violation of the California Labor Code that may be asserted by any person or entity, including, but not limited to, the Contractor, arising out of or in connection with the negligent activities of the Contractor, its agents, employees or privities pursuant to this Contract, whether or not there is concurrent negligence on the part of the Indemnified Parties.

- B. The Contractor shall reimburse the Indemnified Parties for all costs and expenses, (including but not limited to fees and charges of engineers, architects, attorneys, and other professionals and court costs of appeal) incurred by said Indemnified Parties in enforcing the provisions of this Paragraph.
- C. The indemnification obligation under this Section 00800-2.1.6 shall not be limited in any way by any limitation on the amount or type of insurance carried by Contractor or by the amount or type of damages, compensation, or benefits payable by or for the Contractor or any Subcontractor or other person or organization under workers' compensation acts, disability benefit acts, or other employee benefit acts.
- D. Pursuant to California Public Contract Code Section 9201, Owner shall timely notify Contractor of receipt of any third-party claim relating to this Agreement.
- E. The Contractor's obligations pursuant to this provision will survive the expiration or earlier termination of this Contract.

2.1.7 Injury or Illness Reports - The Contractor shall furnish the Construction Manager with a copy of the Employer's Report of Injury immediately following any incident requiring the listing of said report on the OSHA Log during the prosecution of the work under this Contract. The Contractor shall also furnish the Construction Manager with a copy of the Employer's Report of injury involving any subcontractor on this project.

2.1.8 Notification of Insurance Companies - The Contractor shall advise all insurance companies to familiarize themselves with all of the Conditions and provisions of this Contract, and they shall waive the right of special notification of any change or modification of this Contract or of extension of time, or of decreased or increased work, or of the cancellation of the Contract, or of any other act or acts by the Indemnified Parties, under the terms of this Contract, and failure to so notify the aforesaid insurance companies of changes shall in no way relieve the insurance companies of their obligation under this Contract.

2.2 Insurance During Guarantee Period

For all work the Contractor or its subcontractors perform during the guarantee period, worker's compensation, and commercial general liability insurance and insurance in the amounts and format required herein, shall remain in force and be maintained for five (5) years after final completion.

3.0 NOT USED

4.0 NOT USED

5.0 SUBSTANTIAL COMPLETION

Substantial completion of the Project as required by Section 00700-8.6, Substantial Completion, requires that the following portions of the Work must be operational and ready for the Owner's continuous use in accordance with the Contract Documents.

The following items of work must be fully tested and functional for Project Substantial Completion to be attained:

- Completion of the Corrective Work Item List as described in Section 00700-8.6, **Substantial Completion.**
- All testing required by the Contract and Specifications has been successfully completed.
- All record drawings have been submitted, updated, reviewed and approved.

Portions of the Work not essential to the system operation, which can be completed without interruption of system operations, may be completed after the Work is substantially complete, and may include the following items:

- Final Site Clean-Up
- Final Building Clean-Up
- Completion of the Final Punch List prepared by the Construction Manager in accordance with Section 00700-8.6, **Substantial Completion.**

***** END OF SECTION *****

SECTION 01010

SUMMARY OF WORK

1.01 GENERAL

The Contractor shall sufficiently obligate himself/herself and take the necessary precautions so as to perform and complete the work in accordance with the requirements of the contract documents and specifications and/or as shown on the plans and within the specified time limit.

1.02 DESCRIPTION OF WORK

A. WORK INCLUDED IN THIS CONTRACT

Work covered in these contract documents for the construction of the 2024 Sewer Rehabilitation Project - Tiburon and Belvedere consists of the following:

1. Secure all necessary permits and business licenses
2. Locate manholes, rodholes and all service laterals in the field.
3. Pre-clean and pre-televiser sewer mains.
4. Due to planned Town of Tiburon projects, the Contractor's first order of work shall be all work on Main Street including Line A (Alternate Bid Item) and Line B (Base Bid Item).
5. Install new gravity sewers by pipebursting or direct burial as indicated on plans.
6. Remove rodholes as indicated on plans.
7. Connect sewers to existing manholes, rebuild channels, plug holes and seal leaks.
8. Install new rodholes and manholes.
9. Replace lower laterals as indicated on the plans.
10. Replace pavement and private improvements.
11. Televiser finished sewers.

B. COORDINATION

1. The Contractor shall coordinate his/her operations with the District and others working in the immediate area.
2. The Contractor shall conduct his/her operations so as to assure that the existing sewers as well as all other utilities, are kept in continuous operation throughout the execution of this contract. The Contractor, therefore shall schedule and conduct his work so as to minimize interference with operation and maintenance of these facilities. Methods, schedules and sequences of construction which prevent or jeopardize the District's compliance with Clean Water Standards or the NPDES Permit are not acceptable. Bypassing of sewage to the environment is prohibited.

3. When modification, addition or connection to existing pipelines, structures, systems, circuits or equipment is required, the Contractor shall schedule such activities with the Engineer. The Contractor shall notify the Engineer, in writing, one (1) week in advance of the time when construction operations will require connection to, or modification of, in-service portions of the existing facility. No pipeline system, structure, circuit or individual unit shall be cut, modified, dewatered or removed from the facility unless authorized by the Engineer.
4. In the event that the Contractor accidentally damages operating pipes, pump stations or treatment facilities, he/she shall immediately effect the necessary repairs. The Contractor shall maintain an inventory of repair clamps and materials for small pipelines, including temporary pumps, bypass pipelines, electrical conductors or other facilities necessary to maintain operation of sewerage facilities while the repairs are being made. The Contractor shall provide telephone numbers of standby personnel who will respond during non-working hours to repair facilities which interrupt normal operations.
5. If the Contractor fails to respond to a request by the Engineer, the District reserves the right to effect the repair with its own forces or by another contractor. The cost for repairs performed by others will be deducted from the payment due the Contractor.

1.03 CONTRACTOR'S WORK SCHEDULE

A. GENERAL

Unless arrangements are made and approved by the District 48 hours in advance for overtime or Holiday work, the Contractor shall conform to the work hours and work days listed below.

B. WORK HOURS

No work or traffic detouring shall commence before 8:00 AM and all work shall have been completed and traffic restored no later than 5:00 PM.

C. WORK DAYS

No work shall be allowed on Saturdays, Sundays or the following holidays:

1. January 1st, known as New Year's Day
2. The third Monday in January, known as Martin Luther King, Jr. Day
3. The third Monday in February, known as Presidents' Day
4. The last Monday in May, known as Memorial Day
5. July 4th, known as Independence Day
6. The first Monday in September, known as Labor Day
7. November 11th, known as Veteran's Day
8. The fourth Thursday in November, known as Thanksgiving Day
9. The day after Thanksgiving Day
10. December 24th - starting at noon, known as Christmas Eve
11. December 25th, known as Christmas Day
12. December 31st - starting at noon, known as New Year's Eve

When a holiday falls on a Sunday, no work shall take place on the following Monday.
When a holiday falls on a Saturday, no work shall take place on the preceding Friday.
When New Year' Day falls on a Saturday, no work shall take place on the following Monday.

END OF SECTION

THIS PAGE INTENTIONALLY LEFT BLANK

SECTION 01025

MEASUREMENT AND PAYMENT

1.01 GENERAL

The detailed description of bid items and their respective measurement for payment begins on the following page.

1. MOBILIZATION, DEMOBILIZATION AND SWPPP

Shall include the Contractor's mobilization, shop drawing submittal process, preparation and provision of a Storm Water Pollution Prevention Plan, notifications, etc. at the beginning of the project and the demobilization and cleanup at the completion of the project.

Payment for mobilization and demobilization shall be a lump sum (LS) not exceeding 5% of the project cost; 50% of which shall be payable at the beginning of the job upon mobilization and 50% shall be payable at the job completion.

2. PRE-CLEAN AND PRE-TELEVISION SEWER MAINS

Shall include pre-cleaning and internal televising and recording of the interior of all the project sewer mains in advance of pipebursting as required in Section 02659 of the Specifications and determining locations of all lateral connections and submitting digital video copies on CD or thumb drive to Engineer.

Measurement for payment will be in linear foot (LF) of televised new main. Bid quantity includes ten percent (10%) allowance for actual length on slopes.

3. LINES A THRU K 6.63" OD HDPE SEWER MAIN – PIPEBURST

Shall include all potholing, excavation of entry and exit pits, excavation by hand in tight areas, disposal of excavated materials including removal of portions of existing sewer pipe to facilitate pipebursting, dewatering, control of sewage flow, pipebursting existing sewer pipes, furnishing and insertion of HDPE (DR=17) pipe, direct burial where noted on the plans or as necessary, including imported backfill material, pipe bedding, connections to manholes, reconnection of live laterals, compaction, temporary resurfacing, testing and all other work necessary to pipeburst and install the replacement new sewer main, complete, in place.

Measurement for payment will be in linear foot (LF) of sewer main.

4. POTHOLE AND CONSTRUCT AIR GAP FOR PIPEBURSTING AT UTILITY MAIN CROSSING

Shall include, once existing laterals and utility mains have been identified as being closer than 2' to new pipe per plans by pipebursting, all sawcutting up to 12" deep and excavation of Air Gap, excavation by hand in tight areas, disposal of excavated materials including old pipe materials, to protect utility main and ensure busting head does not raise up, complete, in place.

Measurement for payment will be for each (EA) utility.

5. INSTALL (N) STANDARD 4' DIAMETER MANHOLES

Shall include sawcutting up to 12" deep, careful excavation around existing utilities as necessary, disposal of excavated materials, dewatering, construction of new four (4) foot diameter manhole with new cast iron frame and cover as shown in the standard details, control of sewage flow, connections to new and existing pipelines as shown on the plans including pipe stubs and fittings, imported backfill materials, CDF trench dams, compaction, temporary resurfacing, and all other work necessary to install the manhole, complete, in place.

Measurement for payment will be for each (EA) standard manhole.

6. INSTALL (N) SHALLOW MANHOLES

Shall include sawcutting up to 12" deep, careful excavation around existing utilities as necessary, disposal of excavated materials, dewatering, construction of new shallow manhole per the detail in the Plan set, with new cast iron frame in cover as shown, imported backfill materials including CDF, compaction, temporary asphalt surfacing, and all other work necessary to install the manhole, complete, in place.

Measurement for payment will be for each (EA) shallow manhole.

7. REMOVE EXISTING MANHOLES

Shall include excavation and removal of manhole ring and cover and cone and/or concrete or brick barrel sections to a point three (3) feet below the ground surface and backfilling the excavation with intermediate backfill material, compaction and restoration of the surface above the manhole to match existing surrounding area.

Measurement for payment will be for each (EA) structure removed.

8. CONNECT TO EXISTING MANHOLES, REPLACE RIM AND COVER AND GRADE RINGS, REBUILD CHANNELS

Shall include connection to the existing manholes, control of sewage flow, waterstop gaskets on new sewer pipe, as shown on the plans, chipping out and reshaping of the manhole channels as necessary to accommodate the new sewer main including all work necessary to comply with the Contractor's Confined Space Entry Program.

Measurement for payment will be for each (EA) connection.

9. REMOVE AND DISPOSE OF RODHOLES

Shall include removing rodholes, careful excavation around existing utilities as necessary, disposal of excavated and removed materials, dewatering, control of sewage flow, backfilling and compaction, temporary resurfacing and all other work necessary to remove the rodholes and lampholes, complete, in place.

Measurement for payment will be for each (EA) rodholes.

10. LOCATE & POTHOLE EXISTING LATERALS

Shall include physical location of sewer laterals no less than five (5) days in advance of the sewer main installation, excavation of the sewer lateral (pothole) at the main sewer tie-in point to determine if it is live, temporary covering of the excavation with steel plates or with plywood and removal and disposal of excavated material.

Measurement for payment will be for each (EA) sewer lateral to be located.

11. 4" LATERAL CLEANOUTS AND CLEANOUT BOX

Shall include excavation, disposal of excavated materials, including portions of existing lateral pipe and cleanouts to facilitate new cleanout and cleanout box installation, control of sewage flow, furnishing and installing 4" CI two-way cleanouts as shown on the plans and in locations designated by the District, fittings and precast cleanout boxes with cast iron lids, connections to existing house laterals, including all necessary materials, and backfilling, compacting, restoration of all surfacing and landscaping, testing, equipment and labor, complete, in place.

Measurements for payment will be for each (EA) lateral between the sewer main and cleanout, the cleanout cap and box installed.

12. 4" LATERAL, FITTINGS & CONNECTIONS - PIPEBURST

Shall include excavation, control of sewage flow, furnishing and installing 4.5" OD HDPE DR-17 or 4" PVC C-900 DR-18 sewer pipe, connections and fittings, backfill, compaction, temporary resurfacing, replacement of all existing landscaping and improvements that are damaged as a result of the work, and all other work necessary to install the sewer laterals, complete in place.

Measurements for payment will be by linear foot (LF) of new sewer lateral.

13. CURB AND GUTTER AND AC CURB REPLACEMENT

Shall include all excavation, subgrade compaction, formwork, including asphalt and concrete, as necessary for replacement of damaged concrete curbs and changed asphalt curbs, and concrete gutters per Uniform Standards All Cities and County of Marin, complete, in place.

Measurement for payment will be by the linear foot (LF) of curb and gutter replaced.

14. CONCRETE SIDEWALK AND DRIVEWAY APPROACH REPLACEMENT

Shall include all excavation, sawcutting, removal and disposal of existing concrete, subgrade compaction, formwork, placement of concrete, as necessary for replacement of damaged concrete sidewalks and driveway approaches, per Uniform Standards All Cities and Counties of Marin, complete, in place.

Measurement for payment will be by the square foot (SF) of concrete sidewalk and driveway approach replaced.

15. ASPHALT CONCRETE TRENCH REPAIR AND REPLACEMENT OF PAVEMENT MARKINGS

Shall include sawcutting, removal and disposal of existing asphalt and temporary asphalt, recompaction of the Class 2 aggregate base material in the pit, trench, and any other AC surface, compaction of subgrade material below the new asphalt, furnishing, placing and compacting of asphalt concrete to restore asphalt surfacing over trenches, pits and in other locations shown on the plans or designated by the District, all replacement of all pavement markings, including all necessary materials, equipment and labor, complete, in place.

Measurement for payment shall be by ton (TON) of asphalt placed.

16. SHORING FOR ALL EXCAVATIONS

Measurement for payment for temporary sheeting, shoring, and bracing or equivalent method will be based upon the completion of all planning, design, engineering, furnishing, and construction and the removal and disposal of all such temporary sheeting, shoring, and bracing as a lump sum item, complete, as required under the provisions of any permits, and in accordance with the requirements of OSHA and the Construction Safety Orders of the State of California, pursuant to the provisions of Section 6707 and Section 6705 of the California Labor Code.

Groundwater will be present in trench backfill of existing utilities. Contractor shall design shoring and dewatering systems to mitigate against washout or raveling of materials from existing utility trenches.

Payment for sheeting, shoring, and bracing or equivalent method shall be by unit of measure: lump sum (LS), which price named in the Bid Sheet under this Item shall constitute full compensation for completion of all such Work as required per contract documents. Payment will be made for the Work completed in proportion to the total value of the work for this bid item.

17. POTHOLE UTILITY MAINS WITHOUT AIR GAP

Shall include potholing down to utility mains determined to possibly be in conflict with the work using backhoe excavation or by vactor excavation and exposing utility lines near the sewer mains and sewer laterals to be trenched or pipeburst, disposal of all excavated material and payment of all disposal costs, preparation

and submission of a neatly written or type written log in sequential order according to station, indicating station, depth to top of exposed utility, type, material and approximate size of utility, and marking the pavement with the utility type and depth, all necessary shoring, backfill, compaction and temporary resurfacing of the excavation.

Measurement for payment will be (EA) for each pothole of utility mains dug. Potholing of utility laterals and services shall be included in the bid price for sewer line construction and no additional compensation will be allowed (see Sheet 2 of 17, NOTE 19). Potholing of sewer laterals shall be included in the bid price therefor and no additional compensation will be allowed.

18. TRAFFIC CONTROL AND NOTIFICATIONS

Shall include the design and preparation of a traffic control plan for the safe and orderly movement of traffic through the construction area, provision, installation and maintenance of all proposed temporary traffic control devices, delineators, separators and flaggers, including all necessary materials, equipment, incidentals and labor to provide for the safe flow of all modes of traffic through the project area at all times, including written notifications delivered to residents and businesses in the affected areas.

Payment for this item will be a lump sum (LS).

19. PERMITS AND LICENSES

Shall include securing and cost of all necessary permits (encroachment permit fees from the Town of Tiburon and the City of Belvedere have been waived for District Projects) and business licenses necessary for this project.

Measurement for payment will be a lump sum (LS).

20. CLEANING AND TELEVISIONING OF COMPLETED SEWER MAINS

Shall include cleaning and internal televising and recording of the interior of the completed sewer mains upon completion and backfilling of the sewer as required in Section 02659 of the Specifications.

Measurement for payment will be by the linear foot (LF) of televised new main.

21. INTERNAL TELEVISIONING OF COMPLETED LOWER SEWER LATERALS

Shall include internal televising and recording of the interior of the new sewer lower laterals upon completion and backfilling, production of a written log of lower lateral locations and all sags and defects with the date, their locations, together with a color video on flash drive properly labeled as to date, location and line televised per Section 02659 of the Specifications.

If new sewer lower lateral cannot be internally televised, Contractor must verify connection by dye testing lateral in the presence of the Engineer.

Measurement for payment will be by the linear foot (LF) of televised new laterals.

END OF SECTION

SECTION 01030

SPECIAL CONDITIONS

1.01 GENERAL

The Contractor shall comply with the following special conditions.

1.02 PERMITS TO BE OBTAINED BY THE CONTRACTOR

A. GENERAL

The Contractor shall be solely responsible to obtain all necessary permits, pay all permit and inspection fees, and comply with all requirements and obligations imposed upon him/her in the conditions of the permits issued, including but not limited to:

1. Encroachment Permits – Town of Tiburon and City of Belvedere – Contractor shall be reimbursed for the encroachment permit fees only
2. Shoring and Tunneling Permits
3. Business Licenses – Town of Tiburon and City of Belvedere

The Contractor shall furnish the Engineer with a copy of each of the permits which he/she has obtained for the conduct of the construction work.

B. COST OF PERMIT COMPLIANCE

All permit and business license costs, inspection costs associated with construction permits, and all costs of compliance with the requirements of all agencies exercising jurisdiction over the work shall be included in the bid price and no additional compensation will be allowed therefor.

1.03 PRECONSTRUCTION PHOTOGRAPHS

Prior to commencement of any construction activity, the Engineer will take photographs of all work areas.

The Engineer will notify the Contractor at least forty-eight (48) hours in advance of the photography work so that the Contractor and/or his/her inspector(s) can be present. The Contractor may obtain a duplicate set of photographs from the District at cost.

1.04 UTILITIES, POTHOLING AND RELOCATIONS

A. GENERAL

Underground utilities and service connections are not shown on the plans. Overhead utilities including wires, poles and guys are not shown on the plans and shall be determined from the Contractor's visit to the site. It shall be the responsibility of the Contractor to determine the exact location of all utilities and service connections thereto ahead of any excavations through "potholing." The Contractor shall make his/her own investigations, including exploratory excavations, referenced herein as potholing, to

determine the locations and type of existing utilities, including service connections, prior to commencing work which could result in damage to such utilities. The Contractor shall immediately notify the Engineer as to any utility discovered by him/her in a different position than shown on the drawings or which is not shown on the drawings.

B. UTILITY LOCATIONS

Prior to fabrication of engineered pipe and prior to commencing any trenching or excavation work, the Contractor shall contact all affected utility owners and request them to locate and mark the location of their respective utilities on the ground. The Contractor shall then undertake "potholing" procedures as described hereinbelow. If a utility owner is not equipped to provide the locating service, the Contractor shall provide for it. The location of said underground pipes and conduits shall be clearly marked on the pavement or with suitable markers if not on pavement. In addition to the location of metallic pipes and conduits, non-metallic pipe, ducts and conduits shall also be similarly located using surface indicators and shall then be similarly marked.

C. POTHOLING

Immediately following the utility identification and marking described above, and prior to fabrication of engineered pipe, the Contractor shall commence "potholing" to determine the actual location of each of the utility pipes, ducts or conduits. The Contractor shall uncover all underground utilities, including, but not limited to, sewers and storm drains. Underground utilities shall be uncovered to a point one (1) foot below the pipe, where crossing, interferences or connections are shown on the drawings, prior to the preparation of shop drawings, trenching or excavating for any pipe or structure, in order to determine actual elevations. Once uncovered, the Contractor shall record the depth of the utility at the pothole and clearly mark the depth on the pavement. Any variation in the actual elevations and the indicated elevations shall be brought to the Engineer's attention. If the Contractor does not expose all required utilities prior to shop drawing preparation and trenching, he/she shall not be entitled to additional compensation for work necessary to avoid interferences, nor for repair to damaged utilities. Excavations around underground electrical ducts and conduits shall be performed using extreme caution to prevent injury or damage to workers and the electrical ducts or conduits. Similar precautions shall be exercised around gas line, telephone, and television cables.

D. UTILITY RELOCATION PROCEDURES

Any utility relocations shall be coordinated with and/or performed by the owner of the respective utility. In case it should be necessary to remove, relocate or temporarily maintain a utility because of interference with the work, the work on the utility shall be performed and paid for as follows:

1. When it is necessary to remove, relocate or temporarily maintain a service connection, the Contractor shall bear all expenses incidental to the work on the service connection. The work on the service connection shall be done in a manner satisfactory to the owner thereof; it being understood that the owner of the service connection has the option of doing such work with his/her own forces, or permitting the work to be done by the Contractor.

2. When it is necessary to remove, relocate or temporarily maintain a utility which is reasonably close to the position shown on the drawings, the cost of which is not required to be borne by the owner thereof, the Contractor shall bear all expenses incidental to the work on the utility. The work on the utility shall be done in a manner satisfactory to the owner thereof; it being understood that the owner of the utility has the option of doing such work with his/her own forces, or permitting the work to be done by the Contractor.
3. When it is necessary to remove, relocate or temporarily maintain a utility which is not shown on the drawings or is in a position materially different from that shown on the drawings and were it in the position shown on the drawings would not need to be removed, relocated or temporarily maintained, the District will make arrangements with the owner of the utility for such work to be done at no cost to the Contractor, or will require the Contractor to do such work in accordance with the article on changes in the work or will make changes in the alignment and grade of the work to obviate the necessity to remove, relocate or temporarily maintain the utility. Changes in alignment and grade will be ordered in accordance with the article on changes in the work.

The right is reserved to governmental agencies and to owners of utilities to enter at any time upon any street, alley, right-of-way or easement for the purpose of making changes in their property made necessary by the work and for the purpose of maintaining and making repairs to their property.

The Contractor shall be compensated for the costs of locating, repairing damage not due to the failure of the Contractor to exercise reasonable care, and removing or relocating such utility facilities not indicated in the plans and specifications with reasonable accuracy, and for equipment on the project necessarily idled during such work. The Contractor will not be assessed liquidated damages for delay in completion of the project, when such delay was caused by the failure of the public agency or the owner of the utility to provide for removal or relocation of such facilities.

E. UTILITY LOCATIONS

All utilities have reviewed the plans and may be aware of specific problems in respect to their own utilities which may require work on their part to clear the proposed pipeline construction. Prior to starting work, the Contractor shall contact the following people regarding their utilities and any protection work:

Water Mains and Services

Marin Municipal Water District
Engineering Dept. Supervisor:
Joe Ohmart 415/945-1574
Construction Projects:
Andrew Mitchell 415/945-1153
Emergency: 415/945-1500

Gas Mains and Services

Pacific Gas and Electric Company
Engineering:
Bob Gilson 415/257-3404
Jon Freedman 925/979/8038
Emergency: 800/743-5000

Telephone Utilities

SBC/AT&T

Chad Shultz: 707/575-2121

Mike McAfee: 415/456-3560

Emergency: 800/310-2355

Electrical Utilities

Pacific Gas and Electric Company

Service Planning Dept. 415/257-3431

Emergency: 800/743-5000

Television Utilities

Comcast

Paul Alabona 707/759-4070 x219

Emergency: 800/310-2355

Call Before You Dig

800/227-2600 or 811

F. RESPONSIBILITY

The Contractor shall be responsible for all damage to underground utilities whether they are shown on the plans or not, or whether they have been potholed or not. The Contractor shall determine the location of all underground utilities and services through conferring with the utility companies and through potholing as described hereinabove.

G. PAYMENT

The cost of potholing utility mains and services shall be included in the bid price for pipeline construction and no additional allowance will be made therefor.

1.06 CONTRACTOR'S OPERATIONS

The Contractor shall conduct the operations in a manner which will protect adjacent property from annoyance or damage from dust caused by the operations. When necessary, he/she shall take steps to control dust by the application of water, dust palliative, salt or other suitable means. The Contractor shall be responsible for dust control during both working and non-working hours.

During working hours, any open trenches or excavations left unattended shall be covered or properly barricaded with lighted barricades with guard rails. The Contractor shall, at all times, make provision for adequate pedestrian and local vehicle access to residences. The Contractor shall conduct the operations in a manner which will assure the maintenance of public safety at all times.

1.07 WORK IN PUBLIC STREETS AND RIGHTS-OF-WAY

A. GENERAL

Before commencing work, the Contractor shall obtain Encroachment Permits from the Town of Tiburon and City of Belvedere and shall comply with all Encroachment Permit requirements.

Unless otherwise specified in the Encroachment Permit for the work, requirements for work within the public right-of-way, including the pedestrian path, will include, but are not limited to, the following:

1. The Contractor shall not have more than fifty (50) feet of trench under construction without backfill and temporary pavement. Each night all trenches and excavations shall either be backfilled and surfaced with temporary pavement or shall be covered with steel plates with the edges of the plates properly beveled with A.C.
2. At the end of each day, all streets in the work area shall be thoroughly cleaned.
3. Intermediate backfill material and placement shall be in accordance with the standard trench details as shown on the plans, with the provision that in public streets use of native material as backfill will not be allowed except for construction of clay plugs, as shown on the plans.
4. The Contractor shall conduct his operations in a manner which will protect adjacent property from annoyance or damage from dust caused by his operations. When necessary, he shall take steps to control dust by the application of water, dust palliative, salt or other suitable means. The Contractor shall be responsible for dust control during both working and non-working hours.
5. During working hours, any open trenches or excavations left unattended shall be covered or properly barricaded with lighted barricades with guard rails. The Contractor shall, at all times, make provision for adequate pedestrian and local vehicle access to residences. The Contractor shall conduct his operations in a manner which will assure the maintenance of public safety at all times.

B. PAYMENT

The cost of work in public streets and rights of way shall be included in the bid price for pipeline construction and no additional allowance will be made therefor.

1.08 TRAFFIC CONTROL

A. GENERAL

The Contractor shall provide and maintain safe and adequate passage for vehicular and pedestrian traffic over, around, and adjacent to trenches and other excavations by bridging, backfilling and paving, or other approved means as specified herein under the description of detours.

B. TRAFFIC CONTROL

The Contractor shall be responsible for providing adequate traffic control to assure the minimum disruption of and inconvenience to the traffic. The Contractor shall direct and detour traffic in accordance with the traffic control and signing plan, as directed by the Engineer, as directed by representatives of the Town of Tiburon and City of Belvedere (and their respective permits) and as specified herein.

C. SIGNS AND LIGHTS

Temporary signs, lights, and devices shall be in accordance with the California State Division of Highways "Manual of Warning Signs, Lights and Devices for Use in Performance of Work upon Highways," current edition. During the hours of darkness,

approved lights or flares shall be maintained in sufficient numbers, in proper working order, and in proper locations to adequately illuminate the area and alert approaching traffic.

D. NOTICE TO AGENCIES

At least forty-eight (48) hours prior to instituting any detours and/or roadway closures, the Contractor shall notify, in writing, of the proposed detour or closure, the Sanitary District, the Southern Marin Fire Department, Town of Tiburon and City of Belvedere Police, Town of Tiburon Department of Public Works, City of Belvedere Department of Public Works and Golden Gate Transit.

E. DETOUR USE AND ACCESS

During all detours and/or street closures, the Contractor shall provide for movement of emergency vehicles through the work area. Local access to driveways and houses shall be provided within the work area during working hours to the extent feasible. During non-working hours, no driveway or house shall be denied access to a public roadway.

F. BARRIERS AND CROSSOVERS

The Contractor shall provide temporary crossovers at all driveways and streets where it is necessary to maintain traffic. The Contractor shall provide flaggers where necessary to direct traffic. Trenches shall be adequately barricaded and lighted for the protection and safety of the public.

G. PAYMENT

The cost of all traffic control shall be included in the cost for pipeline construction, and no additional allowance will be made therefor.

1.09 PROTECTION AND RESTORATION OF IMPROVEMENTS

A. GENERAL

The Contractor shall protect, shore, brace, support, and maintain all existing surface and subsurface improvements uncovered or otherwise affected by his construction operations. All pavement, surfacing, driveways, curbs, walks, buildings, utility poles, guy wires, fences, and other surface structures affected by construction operations, together with all sod, plantings, and shrubs, shall be restored to match their original condition or better. All replacements shall be made with new materials.

Contractor will be held responsible for any damage to existing structures, work, materials, or equipment because of his operations and shall repair or replace any damaged structures, work materials, or equipment to the satisfaction of, and at no additional cost to, the District.

B. DOCUMENT PRECONSTRUCTION CONDITION

Contractor shall be responsible for preconstruction surveys to document the condition of existing improvements. The Contractor shall be responsible to adequately document the condition for size, kind, quantity and the extent of existing improvements. For sanitary sewer laterals, the Contractor shall provide not less than two still photographs of each lateral location, with date and address noted on back. Photographs shall be for the purpose of documenting the pre-existing condition at the site of work. All surveys shall be delivered to the District prior to commencing work on any given lateral. In the absence of adequate pre-construction documentation, the District's judgment shall be final.

C. TREE AND PLANT PROTECTION

No trees or cultured plants shall be removed or damaged, unless the Contractor obtains the written permission of the property owner and Engineer. Whenever practicable, Contractor shall tunnel beneath trees when on or near the line of trench. Hand excavation shall be employed as necessary to prevent injury to trees and other plants.

All trees and other vegetation that are removed shall be disposed of by the Contractor as approved by the Engineer. All trees and plants not removed shall be protected against injury from construction operations.

Each tree injured beyond repair or removed shall be replaced with a similar tree of the nearest size possible. All trimming, repair, and replacement of trees and plants shall be performed by qualified nurserymen or horticulturists.

The Contractor shall take the following measures when working in the vicinity of trees and shrubs:

1. All pruning and treating of trees shall be done by a professional arborist or established tree service whose operators are skilled in the care of trees, at the expense of the Contractor. The arborist or tree service selected shall be subject to approval by the Engineer.
2. Where a tree to be left standing is so close to the work area that it could not be adequately protected during a conventional trenching operation, the Contractor shall employ an alternative method of excavation for the pipeline such as tunneling or boring.
3. No tree roots shall be unnecessarily cut in excavating or trenching operations. Major roots, defined as roots 2" or larger, which are encountered in the course of excavation shall be exposed but not severed, and they shall be wrapped in plastic as a protective measure while exposed. All other roots that are cut shall be pruned cleanly so that jagged or torn ends do not exist. Where a root has been shattered or jaggedly cut, the Contractor shall dig back to a sound point, but as close as possible to the point of tearing, shattering or splitting and prune the root cleanly.
4. The Contractor shall be responsible for the recovery of any trees damaged or disturbed during construction for a period of one year following the completion of the project.

D. LAWN RESTORATION

All lawn areas that have been disturbed by the contractor's construction activities or by parking of equipment, shall be restored using methods approved by the District. The top surface elevation of the new sod shall match the preconstruction elevation.

The soil used in the repair work shall be commercially available processed topsoil. Sod shall be cut in strips or rectangular sections which may vary in length, but shall be of equal width and of a size that will permit the sections to be lifted and rolled without breaking. All sod shall be cut to a thickness of 1/2 to 3/4 inch.

Fertilizer shall be pelleted or granulated and shall have an analysis of equal parts of available nitrogen, phosphorus, and potassium in percent by weight in order to supply the number of pounds of the pure chemicals per square foot recommended by the manufacturer. Water shall be free from any substances harmful to the growth of grass and shall be from a source approved by the District prior to use.

Sod shall be placed after the soil has been adequately prepared and after the fertilizer has been applied as recommended by the manufacturer. Sod shall be laid smoothly, edge to edge, and with staggered joints.

All sodded areas shall be maintained in accordance with Section 20 of the "State Standard Specifications." Maintenance shall include watering, re-sodding, repair of erosion damage, and all other operations necessary to obtain an acceptable grass cover. Watering shall be required if natural rainfall is not sufficient to maintain the sod bed in a thoroughly moist condition. Contractor shall provide water for watering. Sodded areas that have turned brown prior to final acceptance of the project shall be re-sodded. Original grades of the grass-covered areas shall be maintained after commencement of sodding operations and during the maintenance period.

E. FENCES

All existing fences affected by the work shall be maintained by the Contractor until completion of the work.

Fences which interfere with construction operations shall not be relocated or dismantled until written permission is obtained from the Engineer and owner of the fence and the period the fence may be left relocated or dismantled has been agreed upon. Where fences must be maintained, adequate gates shall be installed. Gates shall be kept closed and locked at all times when not in use.

On completion of the work across any tract of land, Contractor shall restore all fences to their original or to a better condition and to their original location.

F. RESTORATION OF DRIVEWAYS, SIDEWALKS, RETAINING WALLS, CURBS AND GUTTERS

The Contractor shall observe the following requirements:

To the extent possible, construction shall be conducted without disturbing concrete driveways. All concrete curbs, gutters, aprons, patios, walls, driveways, and sidewalks which are broken, crushed, or damaged by the installation of the improvements shall be reconstructed by and at the expense of the Contractor. All restoration shall be of the same kind of material, quality, and of the same dimensions as the original work. The minimum thickness for concrete slabs, etc. shall be no less than adjoining pavement in thickness, or as indicated on the Drawings, or as specified, whichever is the greater.

The repairs shall be made by removing the damaged portions between cold joints, or to nearest weakened plane joint cut by a concrete saw and by replacing the entire portions. Reinforcing dowels shall be placed in existing concrete as approved by the Engineer. Patching the damaged part is not allowed. All work shall match the appearance of the existing improvements as nearly as practicable.

A power-driven pavement saw shall be used to cut existing Portland cement concrete sidewalk, driveway, curb, and gutter where it is necessary to remove the concrete. Sidewalk shall be saw-cut at existing score marks. Driveway aprons shall be removed and replaced as a whole without saw-cutting. The kerf shall be a minimum of 1-1/2 inches and straight; and, if two cuts are made they shall be parallel. The kerf shall be deep enough to permit complete breakage of the concrete without ragged edges.

All edges of concrete shall be edged with a cement edger of the size 2-3/4 inches in width with a 3/16 inch radius. All joints or grooves that are indicated on the Plans or are required by the Engineer shall be marked with cement groovers or jointers 4 inches in width and having a groove 3/8 inch wide at the top and a depth of 1/4 inch to 1/2 inches.

All new or previously existing concrete surfaces shall be left neat, clean, and free from concrete droppings. The Contractor shall be responsible for preventing vandals or others from disfiguring or defacing the finished surfaces. Any new concrete surfaces disfigured, shall be replaced at the Contractor's expense.

G. PAYMENT

The cost of restoration of AC pavement, concrete sidewalks, and concrete curbs and gutters within the public right of way shall be included in the bid items therefor. The cost of restoration of all surface features on private property including sidewalks, retaining walls, patios, fences, gravel, lawn, dirt, and driveways; underground service utilities such as water, phone, power, gas, cable TV, landscaping sprinklers and drain pipes shall be included in the bid price for pipeline construction and no additional allowance will be made therefor. All surface and subsurface features shall be restored to their original construction, function and appearance to the satisfaction of the District.

1.10 ALIGNMENT CHANGES

In the event the Contractor requests a change in alignment to gain the advantage of reduced interference with utilities or other physical hazards and said change is agreed to by the District, the Contractor thereafter shall assume all responsibility for any physical hazards encountered along the realigned route at no additional cost to the District.

The costs of engineering, including surveys and administrative work, incurred by the District in connection with said requested change shall be deducted from payments due the Contractor.

1.11 SOILS INVESTIGATIONS

No soil borings were taken specifically for this project.

The records of investigation of subsurface conditions which are made available by the Engineer are not part of the Contract and are solely for the convenience of the Bidder or Contractor. It is expressly understood and agreed that neither the District nor the Engineer assumes any responsibility whatsoever in respect to the sufficiency or accuracy of the investigations thus made, the records thereof, or the interpretations set forth therein, and there is no warranty or guarantee, either expressed or implied, that the conditions indicated by such investigations or records are representative of those existing throughout such areas or any part thereof, or that unlooked-for developments may not occur, or that materials other than or in proportions different from those indicated, may not be encountered.

1.12 SOILS TESTING DURING CONSTRUCTION

The District will retain a Soils Engineer who will conduct soils tests, such as on the trench backfill material, to determine compliance with the provisions of these specifications. When requested by the Engineer, the Contractor shall provide personnel to dig and properly shore holes in locations and at depths requested by the Soils Engineer so that the necessary soils tests can be performed.

Soil compaction tests will be performed at intervals and at depths necessary for determining compliance with the compaction requirements for pipe bedding, intermediate backfill and surface restoration materials. If the material as placed does not meet the compaction requirements, the Contractor shall recompact the material or remove, replace and recompact. New soils tests will be taken on the recompact material until compaction requirements are met. All such repeated soils compaction tests will be performed at the Contractor's cost.

The Contractor shall provide samples of material for testing by the District's Soils Engineer.

1.13 OTHER TESTS

The Contractor shall provide for other tests as required in the specifications.

1.14 DISPOSAL OF EXCAVATED MATERIAL

The Contractor shall be responsible for making his/her own arrangements for disposal of all excavated material or other materials at a legal disposal site.

1.15 CONTRACTOR STORAGE YARD

The Contractor shall make his/her own arrangements for storage of construction materials.

END OF SECTION

THIS PAGE INTENTIONALLY LEFT BLANK

SECTION 01035

MODIFICATION PROCEDURES

1.0 CHANGES IN CONTRACT PRICE

This section provides supplementary procedures for the administration of changes to the Contract as specified in Section 00700-7.0, **CHANGES IN THE WORK**. Whenever corrections, alterations, or modifications of the work under this Contract are ordered by the Construction Manager and approved by the District which increases the amount of work to be done, such added work shall be known as extra work; and when such corrections, alterations, or modifications decrease the amount of work to be done, such subtracted work shall be known as omitted work.

The difference in cost of the work affected by such change will be added to or deducted from the amount of said Contract price, as the case may be, by a fair and reasonable valuation, which shall be determined in one or more of the following ways as directed by the Construction Manager:

- A. Where applicable, by unit prices accepted by the District and stated in the Contract Documents;
- B. By unit prices subsequently fixed by agreement between the parties;
- C. By an acceptable lump sum proposal from the Contractor; or
- D. By Force Account (as described in Section 01035-3.0, **FORCE ACCOUNT PAYMENT**), when directed in writing and administered by the District through its agents or representatives.

The prices agreed upon and any agreed upon adjustment in Contract Time shall be incorporated in the written order issued by the District, which shall be written so as to indicate an acceptance on the part of the Contractor as evidenced by its signature. By signature of the Change Order, the Contractor acknowledges that the adjustments to cost and time contained in the Change Order are in full satisfaction and accord, payment in full, and so waives any right to claim any further cost and time impacts at any time during and after completion of the Contract for the changes encompassed by the Change Order.

2.0 NEGOTIATED CHANGE ORDERS

Under the methods described in Paragraph 01035-1.0.B and 1.0.C above, the Contractor shall submit substantiating documentation with an itemized breakdown of Contractor's and subcontractor's direct costs, including labor, material, equipment rentals, and approved services, pertaining to such ordered work in the form and detail acceptable to the Construction Manager. The direct costs shall include only costs as described in Section 01035-4.0, **DIRECT COST CATEGORIES**.

The Construction Manager will review the Contractor's proposal for the change and negotiate an equitable adjustment with the Contractor. After there is an agreement, the Construction Manager will prepare and process the Change Order and make a recommendation for action by the District. All Change Orders must be approved by the District in writing before the work can be authorized and the Change Order executed.

3.0 FORCE ACCOUNT PAYMENT

If either the amount of work or payment for a Change Order cannot be determined or agreed upon beforehand, the District may direct by written Change Order or Field Order that the work be done on a force account basis. The term "force account" shall be understood to mean that payment for the work will be done on a time and expense basis, that is, on an accounting of the Contractor's forces, materials, equipment, and other items of cost as required and used to do the work. For the work performed, payment will be made for the documented actual cost of the work as described in Section 01035-4.0, **DIRECT COST CATEGORIES**.

Prior to the commencement of force account work, the Contractor shall notify the Construction Manager of its intent to begin work. Labor, equipment and materials furnished on force account work shall be recorded daily by the Contractor upon report sheets acceptable to the Construction Manager. The reports, if found to be correct, shall be signed by both the Contractor and Construction Manager, or inspector, and a copy of which shall be furnished to the Construction Manager no later than the working day following the performance of said work. The daily report sheet shall thereafter be considered the true record of force account work provided. If the Construction Manager, or inspector, do not agree with the labor, equipment and/or materials listed on the Contractor's daily force account report, the Contractor and Construction Manager, or inspector, shall sign-off on the items on which they are in agreement. The Construction Manager shall then review the items of disagreement and will advise the Contractor, in writing, of its determination. If the Contractor disagrees with this determination, it shall have the right to file a claim notice as provided in Paragraph 00700-7.3.1, Notice.

The Contractor shall maintain its records in such a manner as to provide a clear distinction between the direct costs of work paid for on a force account basis and the costs of other operations.

To receive partial payments and final payment for force account work, the Contractor shall submit, in a manner approved by the Construction Manager, detailed and complete documented verification of the Contractor's and any of its subcontractor's actual costs involved in the force account pursuant to the pertinent Change Order or Field Order. Such costs shall be submitted within thirty (30) days after said work has been performed. No payments will be made for work billed and submitted to the Construction Manager after the thirty (30) day period has expired.

The force account invoice shall itemize the materials used and shall cover the direct costs of labor and the charges for equipment rental, whether furnished by the Contractor, subcontractor, or other forces. The invoice shall be in a form acceptable to the Construction Manager and shall provide names or identifications and classifications of workers, the hourly rate of pay and hours worked, and also the size, type, and identification number of equipment and hours operated. Material charges shall be substantiated by valid copies of vendor's invoices.

4.0 DIRECT COST CATEGORIES

The categories described below are defined to be direct costs. No other type of costs will be allowable as direct costs. Direct costs shall not include any labor costs pertaining to the Contractor's and subcontractor's managers or superintendents, their office and engineering staffs, the cost of their offices, facilities, vehicles, or anyone not directly employed on such work, nor small tools and supplies. All such items are considered indirect costs which form a part of the Contractor's and subcontractors' overhead expenses.

The District reserves the right to furnish such labor, materials and equipment as it deems expedient, and the Contractor shall have no claim for profit or added fees on the cost of such items.

4.1 **Direct Labor**

The Contractor will be paid the cost of direct craft labor for the workers and foremen (when authorized by the Construction Manager) used or proposed to be utilized in the actual and direct performance of the work. District will only pay for the foreman when actually working on the force account work.

The direct labor cost will be the actual payroll cost, including wages, subsistence and travel payments, fringe benefits as established by negotiated labor agreements or state prevailing wages. To these actual wages, will be added a labor surcharge set forth in the State of California Department of Transportation publication entitled Labor Surcharge & Equipment Rental Rates. No other fixed labor burdens will be considered, unless approved in writing by the Construction Manager.

Except as otherwise provided, the Contractor shall receive no additional compensation for wage premiums resulting from overtime work performed under change conditions without the prior written authorization of the Construction Manager.

4.2 **Materials**

The Contractor will be paid the cost of the materials to the purchaser, including tax and delivery if paid. If the Contractor does not furnish satisfactory evidence of the cost of such materials, it shall be deemed to be the lowest current price for the materials delivered to the jobsite for the applicable quantities of the materials.

4.3 **Construction Equipment**

The cost of construction machinery and equipment for changes shall be based on fair rental cost or equivalent rental cost of owned equipment. Such costs will be allowed for only those days or hours during which the equipment is in actual use. Payment shall be based on actual rental and transportation invoices but shall not exceed the rental rates listed for such equipment in the State of California Department of Transportation publication entitled "Labor Surcharge and Equipment Rental Rates" which is in effect on the date upon which the work is performed. Owner-operated equipment rates shall not exceed the rates in the aforesaid Rental Rate publication plus the labor costs as provided in Section 01035-4.1, **Direct Labor**. The rental cost allowed for equipment will, in all cases, be understood to cover all fuel, supplies, repairs, ownership, and incidental costs and no further allowances will be made for those items, unless specific written agreement to that effect is made. No compensation will be provided for tools or equipment of less than one thousand dollars (\$1,000) in value.

5.0 **MARKUP ALLOWANCES**

The Contractor and subcontractors shall be entitled to compensation for indirect field and home office overhead costs, bond and insurance costs, profit and Contractor's risk for Change Order work. This compensation shall be in the form of markup percentages applied to the direct cost of the Change Order work, as further described below. The maximum markup which will be allowed for the Contractor's combined overhead and profit will be:

- A. For work by its own organization, the Contractor may add up to the following percentages:
 - 1. Direct Labor
 - a. Negotiated Change Orders - Section 01035-2.0: 15 percent
 - b. Force Account - Section 01035-3.0: 15 percent
 - 2. Materials: 15 percent
 - 3. Equipment (owned or rented): 15 percent
- B. For all such work performed by subcontractors, such subcontractor may add the same percentages as the Contractor as listed in (A) above to its actual net increase in costs for combined overhead and profit. The Contractor may add up to five (5) percent of the subcontractor's total for its combined overhead and profit. No further compensation will be allowed for the Contractor's administration of the work performed by the subcontractor.
- C. For all such work done by sub-tier-subcontractors, such sub-subcontractors may add the same percentages as the Contractor as listed in (A) above to its actual net increase in costs for combined overhead and profit. The subcontractor may then add up to five (5) percent of the sub-subcontractor's total for its combined overhead and profit. The Contractor may add up to five (5) percent of the subcontractor's total for its combined overhead and profit. No further compensation will be allowed for the subcontractors' and Contractor's administration of the work performed by the sub-tier-subcontractor. No additional mark-ups will be allowed for further tiered subcontracts.
- D. For all such work performed by consultants, engineers, surveyors, etc. there shall be no mark-up or fees with the exception that added to their costs the combined total allowable markup for the Contractor and all subcontractors is five (5) percent of the fee total.
- E. To the total of the actual costs and fees allowed herein under, not more than two and one half (2.5) percent shall be added for additional bond and insurance. The compensable percentage for additional bonds and insurance shall be based on the Contractor's actual costs, as substantiated through documentation submitted to the Construction Manager.

When both additional and deleted work are involved in any one change, the markup allowances of this section shall be applied to the net extra cost of the work, if any, after subtraction of the costs for the omitted work from the extra work. For Change Order work which results in a net decrease in cost a minimum of five (5) percent markup shall be added to the sum of the direct labor, materials and equipment as a deduction for profit, costs, and reduction in bond and insurance. The Contractor shall not be entitled to nor claim for anticipated profits on work that may be omitted.

The added fixed fees shall be considered to be full compensation, covering the cost of general supervision, overhead, profit, Contractor's risk, incidentals and any other general expenses. The above fixed fees represent the maximum limits which will be allowed, and they include but are not limited to the Contractor's and all subcontractors' indirect field and home office expenses and all other costs for cost proposal preparation, schedule analysis and preparation, operation and maintenance manual documentation, record documents and change order administration.

6.0 INCREASED OR DECREASED QUANTITIES

Increases or decreases in the quantity of a Contract unit price bid item of work will be paid on the Contractor's unit bid price given in the bid form even if the quantity varies more than twenty-five percent (25%).

7.0 COST PRICING DATA AND ACCESS TO RECORDS

All cost and pricing data submitted by the Contractor with respect to any change, prospective or executed, or any claim for extra compensation shall be a true, complete, accurate and current representation of actual cost and pricing of the work. The Construction Manager may require a formal certification as to cost and pricing data submitted by the Contractor.

The Construction Manager shall have access, upon reasonable notice during normal business hours, to any books, documents, accounting records, papers, project correspondence, project files, scheduling information and other relevant records of the Contractor and all subcontractors directly or indirectly pertinent to the work, original as well as changes and claimed extra work, and the Contract for the purpose of making audit, examination, excerpts and transcriptions and in order to verify or evaluate any change, prospective or executed, or any claim for which compensation has been requested or notice of potential claim has been tendered.

Such books, documents, and other records mentioned above shall include, but are not limited to all those reasonably necessary to determine the accurate amount of direct and indirect costs, job site, and delay and impact costs, however characterized, and shall include the original Bid and all documents related to the Bid and its preparation, as well as, the as-planned construction schedule and all related documents.

Such access shall include the right to examine and audit such records and make excerpts, transcriptions, and photocopies at the District's cost.

8.0 TIME EXTENSIONS FOR CHANGE ORDERS

If the Contractor requests a time extension for the extra work necessitated by a proposed Change Order, the request must comply with the applicable requirements of Paragraph 01310-6.0, **TIME IMPACT ANALYSES**.

9.0 COST-REDUCTION INCENTIVE (NOT USED)

END OF SECTION

THIS PAGE INTENTIONALLY LEFT BLANK

SECTION 01090

REFERENCES

1.0 CODES AND STANDARDS

Whenever reference is made to a code or standard, it means the latest edition in effect the date that the Contract Documents are dated. Where codes, standards and reference documents are referred to in the Contract Documents, the Contractor may submit a written request to the Construction Manager for assistance in locating such documents. Within three days of receipt of such request, the Construction Manager or the Design Consultant will notify the Contractor as to where the document(s) can be reviewed.

2.0 DEFINITIONS OF WORDS AND TERMS

Where used in the project manual, the following words and terms shall have the meanings indicated. The meanings shall be applicable to the singular, plural, masculine and feminine of the words and terms.

Acceptance. Formal action of the District's Board of Directors in determining that the Contractor's work has been completed in accordance with the Contract Documents and in notifying the Contractor in writing of the acceptability of the Work.

Acts of God. "Acts of God" shall include only the following occurrences or conditions and effects: earthquakes in excess of a magnitude of 3.5 on the Richter Scale and tsunamis.

Addenda. Supplemental written specifications or drawings issued prior to bid submittal which modify or interpret the project manual by addition, deletion, clarification, or corrections.

Agreement. The written document covering the performance of the Work as more fully described in the Contract Documents.

Bid. Offer of a bidder submitted on the prescribed form setting forth prices of the work to be performed.

Bidder. Individual, partnership, corporation, or a combination thereof, includes joint venturers offering a bid to perform the work.

City. Refers to City of Belvedere.

Clarification Letter. A Clarification Letter is issued by the Construction Manager to address the clarification of Contract issues raised by the Construction Manager, Design Consultant or District.

Completion. The word completion shall indicate substantial completion. See Substantial Completion.

Construction Manager. The person designated, in writing, by the District to act as its representative at the construction site and to perform construction inspection services and administrative functions relating to this Contract. All contact by the Contractor with the District shall be through the Construction Manager.

Contract Change Order. A written order to the Contractor, covering changes in the plans or specification quantities, or both, and establishing the basis of payment and time adjustments for the work affected by the changes. Also referred to as a Change Order.

Contract Documents. The words "Contract Documents" shall mean any or all of the following items, as applicable:

- Notice Inviting Bids
- Instructions to Bidders
- Bid Form and Bid Schedule
- Designation of Subcontractors
- Bidder's Bond
- Agreement
- Performance Bond
- Payment Bond
- Insurance Endorsements
- Non-Collusion Affidavit
- General Conditions
- Supplementary General Conditions
- General Requirements
- Specifications
- Drawings
- Addenda, if any
- Executed Change Orders, if any
- Field Orders
- Notice to Proceed
- Permits

Each of these items is to be considered by reference as part of the Contract Documents, also referred to as Contract.

Contract Price (also referred to as Contract Amount). The amount payable to the Contractor under the terms and conditions of the Contract based on the price given on the bidding schedule, with adjustments made in accordance with the Contract. The base amount given in the bidding schedule shall be either a lump sum bid or the summation of the unit price bids multiplied by the estimated quantities set forth in the bid form.

Contract Time. Number of calendar days stated in the Contract for the completion of the Work.

Contractor. The individual partnership, corporation, or combination thereof including joint venturers who enter into the Contract with the District for the performance of the Work. The term covers subcontractors, subtier subcontractors, consultants, equipment and material suppliers, and their employees.

Contractor's Plant and Equipment. Equipment, material, supplies, and all other items, except labor, brought onto the site by the Contractor to carry out the Work, but not to be incorporated in the Work.

Corrective Work Item List. List of incomplete items of work, incomplete administrative requirements and items of work which are not in conformance with the Contract, prepared by the Construction Manager and issued to the Contractor as an attachment to the response to the Contractor's notification of Substantial Completion.

Days. The word "Days" shall mean calendar days, including legal holidays, Saturdays and Sundays, unless specifically noted otherwise.

Design Consultant. The engineer or architect designated by the District to have design control over the Work or a specified portion of the Work, acting either directly or through duly authorized representatives. Such representatives shall act within the scope of the particular duties delegated to them. The Design Consultant may also furnish inspection services as provided by the Contract.

Direct. Action of the District or Construction Manager by which the Contractor is ordered to perform or refrain from performing work under the Contract.

District. The word "District" refers to the San Rafael Sanitation District, the governing body of which is termed the Board.

District Representative. The person designated in writing by the District to act as its agent on specified matters relating to this contract. The District's Representative is not the Construction Manager, but an employee of the District who has been designated to represent the District.

Drawings. Also referred to as "Plans". That part of the Contract Documents consisting of the graphical and technical requirements of the Contract as included on the plan sheets.

Engineer. Engineer shall refer to either the Construction Manager or Design Consultant based on their roles as defined in Section 00700, **GENERAL CONDITIONS**, and their separate contracts with the District.

Field Directive. Written documentation of the actions of the District or Construction Manager in directing the Contractor. Also referred to as a Directive.

Field Order. A written instruction given to the Contractor authorizing work that is a change to the scope of work carried out on a time and material basis.

Final Inspection List. List of materials, equipment, workmanship, or administrative requirements which are not in conformance with the Contract. The list shall be prepared by the Construction Manager and submitted to the Contractor following the Contractor's notice of completion of the Work, including all items on the Punch List.

Float. Float or "total float" shall be defined as provided in the Associated General Contractors of America "CPM in Construction, A Manual for General Contractors".

Furnish. To deliver to the job site or other specified location any item, equipment or material.

General Conditions. Sections 00700, **GENERAL CONDITIONS**, and 00800, **SUPPLEMENTARY GENERAL CONDITIONS**, which form the part of the Contract Documents representing the general clauses that establish how the Project is to be administered.

General Requirements. Division 1, **GENERAL REQUIREMENTS**, which forms the part of the Contract Documents establishing special conditions or requirements peculiar to the Work and supplementary to the General Conditions.

Herein. Refers to information presented in the Contract Documents.

Holidays. Legal holidays shall include the following holidays designated by the District: New Year's Day, Martin Luther King Jr. Day, President's Day, Caesar Chavez Day, Memorial Day, Independence Day, Labor Day, Thanksgiving Day, the day after Thanksgiving, Christmas Eve, Christmas Day and New Year's Eve.

Install. Placing, erecting, or constructing complete in place any item, equipment, or material.

Notice to Proceed. Notice to Proceed shall mean the written notice issued by District to Contractor authorizing him to proceed with the work and establishing the date of commencement of the Contract Time. Notice to Proceed may or may not include separate dates establishing the date of commencement of the submittal process.

Owner. The word "Owner" shall have the same meaning as the term "District".

Paragraph. For reference or citation purposes, a paragraph shall refer to the paragraph, or paragraphs, called out by paragraph number and alphanumeric designator.

Person. The term, person, includes firms, companies, corporations, partnerships, and joint ventures.

Plans. See "Drawings".

Project. The undertaking to be performed under the provisions of the Contract Documents.

Project Manual. The bound documentary information prepared for bidding and constructing the work. A listing of the contents of the Project Manual, which may be bound in one or more volumes, is contained in the Table of Contents.

Provide. Furnish and install, complete in place.

Punch List. List of incomplete items of Work, incomplete administrative requirements and items of Work which are not in conformance with the Contract, prepared by the Construction Manager and issued to the Contractor as an attachment to the Certificate of Substantial Completion.

Request for Information. Also referred to as “Request for Clarification”. A Request for Information (RFI) is issued by the Contractor to the Construction Manager to request resolution of a question on a Contract issue. A RFI is not to be used for request for material/equipment substitutions or value engineering/cost reduction incentive proposals.

Shall. Refers to actions entered into by the Contractor or the District as a covenant with the other party to do or to perform the action.

Shown. Refers to information presented on the drawings, with or without reference to the drawings.

Specifications. That part of the Contract Documents consisting of written descriptions of the technical features of materials, equipment, constructions systems, standards, and workmanship.

Specify. Refers to information described, shown, noted or presented in any manner in any part of the contract.

State of California Specifications. The State of California Department of Transportation Standard Specifications in effect at the date of Notice Inviting Bids, Section 00010. Also referred to as State Standard Specifications and Caltrans Standard Specifications.

Subcontractor. A subcontractor is a person or entity who has a direct contract with the Contractor or a subtier subcontractor who has a direct contract with a subcontractor to perform any of the Work associated with the Project. The term subcontractor means a subcontractor or subcontractor's authorized representative. The term subcontractor, does not include any separate contractor or any separate contractor's subcontractors.

Submittals. The information which is specified for submission to the Construction Manager in accordance with the Contract Documents.

Substantial Completion. Sufficient completion of the project or the portion thereof to permit a utilization of the project. Determination of substantial completion is solely at the discretion of the District. Substantial completion does not mean complete in accordance with the Contract nor shall substantial completion of all or any part of the project entitle the Contractor to acceptance under the Contract.

Substantial Completion Date. Date when the District puts into service, the Project, or that portion of the Project that has been determined to be substantially complete.

Sub-subcontractor. A sub-subcontractor is a person or entity who has a direct or indirect contract with a subcontractor to perform any of the Work associated with the Project. The term sub-subcontractor means a sub-subcontractor or an authorized representative thereof, also referred to as subtier-subcontractor.

Supplier. Any person, firm, corporation, or organization who supplies materials or equipment for the Work, including that fabricated to a special design, and may also be a Subcontractor or a Sub-contractor.

Surety. The person, firm, corporation, or organization that joins with the Contractor in assuming the liability for the faithful performance of the Work and for the payment of all obligations pertaining to the Work in accordance with the Contract Documents by issuing the Bonds required by the Contract Documents or by law.

Town. Refers to Town of Tiburon.

Will. See definition of "Shall".

Work. The labor, materials, equipment, supplies, services, and other items necessary for the execution, completion and fulfillment of the Contract.

Work Day. Any day except Saturday, Sunday, and legal holidays. For time extension purposes a work day is equivalent to 1.45 calendar days.

3.0 ABBREVIATIONS

Whenever the following terms are used, the intent and meaning shall be as follows:

Abbreviation Stands For

AASHTO	American Association of State and Highway and Transportation Officials
AAMA	Architectural Aluminum Manufacturers Association
ABMA	American Boiler Manufacturers Association
ACI	American Concrete Institute
ADC	Air Diffusion Council
AGA	American Gas Association
AGMA	American Gear Manufacturers Association
AISC	American Institute of Steel Construction
AISI	American Iron and Steel Institute
AMCA	Air Moving and Conditioning Association
ANSI	American National Standard Institute (formerly United States of America Standards Institute)
APA	American Plywood Association
API	American Petroleum Institute
AREA	American Railway Engineers Association
ASCE	American Society of Civil Engineers
ASHRAE	American Society of Heating, Refrigerating and Air Conditioning Construction Managers
ASME	American Society of Mechanical Engineers
ASTM	American Wood-Preserver's Association
AWS	American Welding Society
AWWA	American Water Works Association
CAGI	Compressed Air and Gas Institute CAL/OSHA State of California Department of Industrial Relations, Division of Industrial Safety
CBC	California Building Code
CBM	Certified Ballast Manufacturers
CBR	California Bearing Ratio
CI	Chlorine Institute

CISPI	Cast Iron Soil Pipe Institute
CMAA	Crane Manufacturers Association of America
CPSC	Consumer Products Safety Commission
CRA	California Redwood Association
CRSI	Concrete Reinforcing Steel Institute
CTI	Cooling Tower Institute
DFPA	Douglas Fir Plywood Association
EIA	Electronic Industries Association
EPA	U.S. Environmental Protection Agency
ETL	Electronic Testing Laboratory
FM	Factory Mutual Insurance Company
FPS	Fluid Power Society
FS	Federal Specifications
GO 95	General Order No. 95, California Public Utilities Commission Rules for Overhead Electric Line Construction
HI	Hydraulic Institute
HMI	Hoist Manufacturers Institute
IAPMO	International Association of Plumbing and Mechanical Officials
IBR	Institute of Boiler and Radiator Manufacturers
ICBO	International Conference of Building Officials
IEEE	Institute of Electrical and Electronic Engineers
IES	Illuminating Engineering Society
IPCE	International Power Cable Engineers Association
ISA	Instrument Society of America
MIL	Military Specifications
MSS	Manufacturer's Standardization Society
NAAMM	National Association of Architectural Metal Manufacturers
NBS	National Bureau of Standards
NEC	National Electric Code
NEMA	National Electrical Manufacturers Association
NFPA	National Fire Protection Association
NSF	National Sanitation Foundation
NWMA	National Woodwork Manufacturers Association
OSHA	Occupational Safety and Health Administration
PCMAC	Prestressed Concrete Manufacturers Association of California
SMACNA	Sheet Metal and Air Conditioning Contractors National Association
SSPC	Structural Steel Painting Council TCA Tile Council of America
UBC	Uniform Building Code
UFC	Uniform Fire Code
UPC	Uniform Plumbing Code
UL	Underwriters Laboratories
WCLIB	West Coast Lumber Inspection Bureau
WIC	Woodwork Institute of California

*** END OF SECTION ***

THIS PAGE INTENTIONALLY LEFT BLANK

SECTION 01200

PROJECT MEETINGS

1.0 PRE-CONSTRUCTION CONFERENCE

Prior to the start of construction the Construction Manager will conduct a pre-construction conference that shall be attended by the Contractor's Project Manager/Project Engineers and major subcontractors and major equipment and material suppliers, effected utilities and others as determined by the Contractor and Construction Manager. At the conference the following shall be reviewed - the Contractor's proposed schedule of operations and the construction procedure and sequence requirements, Contractor's field organization, submittals, progress payment procedures, change order procedures, Contractor Safety Program, safety requirements, permits and inspections, and other matters.

2.0 PROGRESS MEETINGS

The Construction Manager shall schedule, arrange and conduct progress meetings. These meetings shall be conducted not more than once per week and shall be attended by the Contractor's superintendent and representatives of all subcontractors, utilities, and others, who are active in the execution of the Work. The purpose of these meetings shall be to review the Contractor's three week schedule provided in accordance with Section 01310-7.0, **WEEKLY ACTIVITIES PLAN**, resolve conflicts, and in general, coordinate and expedite the execution of the Work.

The agenda of progress meetings shall include, as a minimum, review of progress and schedule of the Work and any other matters related to the execution of the Work. The Construction Manager shall prepare and distribute record of discussions of the meetings.

3.0 OTHER PROJECT MEETINGS

The Contractor shall attend and require the participation of other subcontractors or suppliers for other project related meetings when requested by the Construction Manager or District.

END OF SECTION

THIS PAGE INTENTIONALLY LEFT BLANK

SECTION 01310

PROGRESS SCHEDULE

1.0 GENERAL

The Progress Schedule for this Project will also be referred to as the Critical Path Method (CPM) Schedule.

The Contractor shall designate, in writing, an authorized representative in its firm who will be responsible for the preparation, revising, and updating of the CPM Schedule. The Contractor's representative shall have direct project control and complete authority to act on behalf of the Contractor in fulfilling the construction scheduling requirements set forth herein, and such authority will not be interrupted throughout the duration of the Project. The requirements for the CPM Schedule are included to assure adequate planning and execution of the work and to assist the Construction Manager in appraising the reasonableness of the proposed schedule and evaluating progress of the work.

The Contractor shall provide a compact disk (CD) with a properly formatted electronic file for the Preliminary Progress Schedule, Base Schedule and all monthly updates with the logic network diagram and mathematical analyses.

2.0 Not Used

3.0 CONSTRUCTION SCHEDULE

3.1 Demonstration of Competence

Within seven (7) days from award of the Contract, the Contractor shall submit to the Construction Manager demonstration of competence in the use of CPM Scheduling, including evidence of the use of CPM Scheduling projects similar in value and complexity. In the event of the failure of the Contractor to satisfy the Construction Manager of its CPM Scheduling competence, the Contractor will be required to employ a qualified CPM consultant who regularly performs these services and who in the opinion of the Construction Manager possesses the qualifications required to perform CPM Scheduling for this Project.

Demonstration of competence in the use of CPM Scheduling shall be indicated by providing evidence to verify capability of using the critical path method of construction scheduling by submitting: (1) The Contractor's or its CPM Consultant's experience in the application of CPM Scheduling techniques for at least two construction projects of similar size and complexity which were successfully controlled by the Contractor or its CPM consultant throughout their duration by means of CPM Scheduling and periodic systematic reviews of the CPM Schedules; (2) The Contractor's or its CPM consultant's experience with computer programs for production of CPM Schedules; and (3) Information regarding the Contractor's or its CPM consultant's computer facilities (either by possession or contractual access).

3.2 **Preliminary Progress Schedule**

3.2.1 Within five (5) days after receipt of Notice to Proceed or Preconstruction Conference, whichever occurs first, the Contractor shall submit two (2) copies each of a Preliminary Progress Schedule in the form of time scaled logic diagram and a bar chart covering the following project phases and activities:

- a. Procurement and Submittals, including shop drawings and fabrication and delivery of key and long lead time procurement items.
 1. The Contractor's submittal information shall show intended submittal dates and shall include, as a minimum, the maximum allowable review period as specified as a separate predecessor activity.
 2. The information shall provide sufficient durations for administration, fabrication and transportation to produce realistic delivery dates for the procurement items.
- b. All activities planned for the first 90 days in the execution of the Work.
- c. The approach to scheduling the remaining activities or phases of the Work shall be represented by at least one summary activity for each major phase or activity. The total duration of the summary activities shall equal the Contract Time.
- d. Approximate duration for each summary activity representing the Contractor's best estimate for the work the summary activity represents.

3.2.2 The Preliminary Progress Schedule shall describe the activities to be accomplished and their dependency subject to all requirements under these Construction Schedule provisions, as appropriate. The Preliminary Progress Schedule will be used temporarily to record and monitor the progress of the Work until the Base Schedule, specified hereinafter, has been completely developed and favorably reviewed. Recorded data on the Preliminary Progress Schedule shall be incorporated into the Base Schedule during the first schedule update.

3.2.3 The Construction Manager shall review the Preliminary Progress Schedule and provide any comments, its favorable review of the Preliminary Progress Schedule, or request a meeting to review the Preliminary Progress Schedule with the Contractor within ten (10) days of receipt of the schedule. If requested, the Contractor shall participate in a review and evaluation of the schedule with the Construction Manager. Any revisions necessary as a result of this review shall be resubmitted for review by the Construction Manager within five (5) days.

3.3 **Base CPM Schedule**

3.3.1 **Base CPM Schedule Submittal** - The Contractor shall submit an acceptable Critical Path Method (CPM) Schedule to the Construction Manager within thirty (30) days after the receipt of the Notice to Proceed. Subsequent revisions to said Schedule shall be submitted as set forth hereinafter.

The Contractor shall produce and provide one (1) complete set each of time-scaled network logic diagrams and bar charts on 22-inch by 34-inch sheets. The network logic diagram shall be clear and legible. Critical activities shall be indicated in red color on both schedules.

The Construction Manager shall review the schedule and provide any comments, its favorable review of the schedule, or request a meeting to review the schedule with the Contractor within twenty (20) days of receipt of the schedule. If requested, the Contractor shall participate in a review and evaluation of the proposed network diagrams and analysis by the Construction Manager. Any revisions necessary as a result of this review shall be resubmitted for review by the Construction Manager within twenty (20) days. When completed, the favorably reviewed schedule shall then be the schedule to be used by the Contractor for planning, organizing, and directing the work, and for reporting progress. If the Contractor thereafter desires to make significant changes in its method of operating and scheduling, the Contractor shall notify the Construction Manager in writing stating the reasons for the change.

No more than two progress payments will be made prior to submission and favorable review of the CPM Schedule by the Construction Manager.

To the extent that the favorably reviewed initial Construction Schedule, or revisions thereto, indicate anything not jointly agreed upon, it shall be deemed to be not favorably reviewed by the Construction Manager. Any omission of work from the detailed Base Schedule, otherwise required for Contract compliance, will not excuse the Contractor from completing such work within any applicable completion date.

3.3.2 Schedule Type - The CPM Schedule submitted under this Specification shall indicate completion of the project at the Contract completion date and shall incorporate the entire project duration. As provided for in Section 00700-6.2, **Contract Time**, the Contractor is required to base their bid and the construction schedule on the entire Contract Time and include its field and home office overhead costs in the bid for the entire Contract Time as defined in Section 00800-1.1, **Time Allowed for Completion**.

The critical path is defined as the longest continuous path of activities in a network logic diagram with the least amount of float.

The schedule shall be computer generated utilizing “**SureTrak**”, “**Primavera**” or a compatible scheduling program. The Contractor shall provide the Construction Manager with conversion software from the Contractor's scheduling program to the “**SureTrak**” or “**Primavera**” system. The program shall be capable of accepting revised completion dates as modified by approved time adjustments and recomputations of all tabulation dates and float accordingly.

The CPM Schedule shall not incorporate resource loading and leveling. The Contractor shall provide hard coded logic constraints as necessary to incorporate any resource requirements that may be applicable to the Project construction. The Contractor shall determine and allocate the proper resources to complete the Project by the specified Contract completion date.

3.3.3 Network Logic Diagram - The graphic network diagram shall include for each activity, the description, activity number, the estimated duration in workdays, and all activity relationship lines. The network diagram shall be drawn for the early start and early finish of all activities.

The diagrams shall show elements of the project in detail and an entire project summary. Diagrams shall show the order and interdependence of all activities and sequence in which the work is to be accomplished as planned by the Contractor and its subcontractors. The basic concept of a network analysis diagram shall be followed to show how the start of a given activity is dependent on the

completion of preceding activities and its completion restricts the start of following activities. Network logic diagrams shall be time-scaled.

3.3.4 Reports – Two (2) copies of the following reports shall be provided.

(1) Tabular Reports

- a. Activity Report: Sort report by Activity ID
- b. Total Float Report: Sort report by Total Float, Early Start, Activity ID

(2) 11"x17" Color Time-Scaled Diagram: Breakdown by Work Area

The following information shall be furnished as a minimum for each activity;

- a. activity description and number
- b. estimated duration of activities
- c. earliest start date (by calendar date)
- d. earliest finish date (by calendar date)
- e. actual start date (by calendar date)
- f. actual finish date (by calendar date)
- g. latest start date (by calendar date)
- h. latest finish date (by calendar date)
- i. float
- k. percentage of activity completed.

In addition provide two (2) copies of the following report:

- (3) Tabular Report – Predecessor/Successor Report: The report shall include the same information listed above plus the additional information listed below. This report shall be sorted by Activity ID.
 - a. preceding and succeeding activities
 - b. activity constraints

The schedule reports shall include a calendar in workdays.

3.3.5 Durations - Durations shall be in working days and shall not exceed ten (10) workdays, except for submittal and delivery items. Where the duration of continuous work exceeds ten (10) workdays, work items in the Construction Schedule shall be subdivided by location, approximate stationing or other sub-element of the work.

3.3.6 Network Activities - Detailed network activities shall include:

- a. The submittal and approval of samples and equipment, fabrication of special material and equipment and their installation and testing.
- b. The critical path shall be shown on all reports and on the graphic network logic diagram. The activities which constitute the critical path shall be identified.
- c. Progress milestone events or other significant stages of completion, as defined in Section 00800-1.1, **Time Allowed for Completion**, and Section 01010-2.0, **WORK SEQUENCE AND CONSTRAINTS**. System shutdown and tie-in dates must be specifically and conspicuously identified and included on the schedule.
- d. The lead time required for testing, inspection and other procedures required prior to acceptance of the work.

- e. The activity numbers shall be grouped by work area, trade and subcontractor to provide logical summary activities.
- f. All activities of the District and the Construction Manager that affect progress along with required contract dates for completion of all parts of the work. The selection and number of activities shall be subject to favorable review by the Construction Manager.

3.3.7 Float – “Total Float” or “Float” shall be defined as the difference between the early finish and late finish dates for an activity.

On the CPM Schedule delineate the specified Contract duration and identify the planned completion of the Work as the final finish milestone. The time period between these two dates, if any, shall be considered Contract float.

If the Contractor’s schedule is based on less time than the maximum time allowed for milestone(s) or Contract completion no compensation for indirect overhead expenses will be considered until the expiration of the entire time periods provided for in the Contract as adjusted by any time extensions granted other than compensable time extensions. In such case refer to Section 00700-6.4.3, **Indirect Overhead**, for further provisions on the reimbursement of indirect overhead expenses.

Float in any activity, milestone completion date or Contract completion date shall be considered a resource available to both the District and the Contractor. Neither the District nor the Contractor has ownership of the float. Float is for the benefit of the Project.

Acceptance of the Contractor’s Base CPM Schedule, monthly updates or revised schedule, when based on less time than the maximum time allowed for milestone(s) or Contract completion does not serve to change any Contract duration, nor serve as a waiver of the Contractor’s nor the Owner’s right to utilize the full amount of time specified in the Contract, unless so modified in a Contract Change Order.

4.0 WEATHER CONDITIONS

Seasonal weather conditions shall be considered in the planning and scheduling of work activity durations influenced by high or low ambient temperatures or precipitation to ensure the completion of the Work within the Contract Time. No time extensions will be granted for the Contractor's failure to take into account such weather conditions for the location of the Work and for the period of time in which the Work is to be accomplished.

The expected loss of working days specified in the Supplementary General Conditions, Section 00800-1.3, **Weather Days**, shall be included in a separate identifiable critical activity labeled "Weather Days Allowance" to be included as the last critical activity of the project schedule. When weather days are experienced, and are approved as such by the Construction Manager, the Contractor shall either:

- a. Increase the duration of the current critical activity(ies) by the number of weather days experienced, or
- b. Add a critical activity to the schedule to reflect the occurrence of the weather day(s).

The duration of the weather day allowance activity shall be reduced as weather days are experienced and included in the schedule. Any remaining weather days in the weather day allowance activity at the completion of the project shall be considered as float and shall not be for the exclusive use or benefit of either the District or Contractor.

5.0 UPDATES

5.1 Submittal Period

The Contractor shall submit at monthly intervals a report of the actual construction progress. Each monthly report shall cover a period of approximately thirty (30) days. The monthly reports shall be submitted within ten (10) days of the end of the reporting period. The end of the reporting period shall be as agreed upon by the Construction Manager and Contractor.

Produce and provide one (1) complete set each of time-scaled logic diagrams and bar chart on 22-inch by 34-inch sheets. The network diagram shall be clear and legible. Critical activities shall be indicated in red color. Progress bars shall be conspicuously identified by color other than red, black or white.

5.1.1 All Monthly Updates - All monthly updates shall include as a minimum:

- a. Reports - Provide the reports defined in Section 01310-3.3.4, Reports.
- b. Narrative and Tabular Report - The report shall show the activities or portions of activities completed during the reporting period. The report shall state the percentage of the work actually completed and scheduled, the remaining duration, and the progress along the critical path in terms of days ahead or behind the allowable dates as of the report date. Any changes made by the Contractor to the CPM schedule, including activity numbers, durations, constraints and activity descriptions, shall be listed in a detailed report which describes the reason for each.
- c. Activity Numbers and Descriptions – New activity numbers and descriptions may be added where required to further define the work and as approved by the Construction Manager. Activities may be deleted if the applicable work has not been performed and is deleted from the Work and as approved by the Construction Manager.

5.1.2 Delayed Schedule Updates - If, in the opinion of the Construction Manager, the project is behind schedule, the monthly report shall include a revised network logic diagram and/or tabular reports showing the Contractor's proposed revised CPM schedule. The CPM schedule shall be revised under the conditions defined in Section 01310-5.3, Schedule Revisions. An analysis of the effect that the delay has on progress along other paths shall also be included in the report. The Contractor shall also submit a narrative report with each updated analysis which shall include but not be limited to, a description of current and anticipated problem areas, delaying factors and their impact, and an explanation of corrective actions taken or proposed.

5.2 Schedule Review

Once each month, on a date mutually agreed upon, but no later than ten (10) days after the submittal of the monthly update specified herein, a jobsite meeting will be held to review the CPM

Schedule, job progress and the monthly update, or the Construction Manager will provide written comments on the monthly update.

5.3 **Schedule Revisions**

The conditions under which the Construction Manager will require revisions of the CPM Schedule include the following:

- a. When delay in completion of any work item or sequence of work items results in an estimated extension of project completion by either twenty (20) working days or by five percent (5%) of the remaining duration of time to complete the Contract, whichever is less.
- b. When delays in submittals or deliveries make replanning or rescheduling of the work necessary.
- c. When the schedule does not represent actual prosecution and progress of the work.
- d. When any change to the sequence of activities, the completion date for major portions of the Work, or changes occur which affect the critical path.
- e. When Contract modification necessitates schedule revision.

6.0 **TIME IMPACT ANALYSES**

When change orders are initiated, delays are experienced, or the Contractor desires to revise the schedule logic, the Contractor shall submit to the Construction Manager a written Time Impact Analysis illustrating the influence of each change, delay, or Contractor request on the current contract schedule completion date.

6.1. **CPM Schedule - Analysis**

- a. Each Time Impact Analysis shall include a fragmentary network analysis demonstrating how the Contractor proposes to incorporate the change order, delay, or Contractor request into the CPM Schedule.
- b. The analysis shall demonstrate the time impact based on the date of occurrence of the change, delay or revision; the status of construction at that point in time; and the event time computation of all affected activities.
- c. The event times used in the analysis shall be those included in the latest updated copy of the CPM Schedule or as adjusted by mutual agreement between the Construction Manager and Contractor.

6.2 Activity time delays will not automatically mean that an extension of Contract Time is warranted or due the Contractor.

- a. It is possible that an excusable delay or contract modification will not affect existing critical activities or cause noncritical activities to become critical, i.e., a delay or modification may result in only absorbing a part of the available total float that may exist within an activity chain of the network, thereby not causing any effect on the Contract completion date or time.

- b. The Contractor acknowledges and agrees that mitigation for delays due to changes, differing site conditions, and other causes will require revision of preferential sequences of the Work. Accordingly, to mitigate delays, the activities shall be resequenced prior to the Contractor proposing an updated schedule which supports a delay to the Project as a whole. When a delay to the Project as a whole can be avoided by revising preferential sequencing, and the Contractor chooses not to implement the revisions, the Contractor will be entitled to a time extension but is not entitled to compensation for indirect overhead for this extended duration.
- c. Actual delays in activities which do not affect the critical path work or which do not move the Contractor's planned completion date beyond a milestone or the Contract completion date will not be the basis for an adjustment to the Contract Time.
- d. Extensions of time can be granted for a delayed or impacted activity only for the duration of the time adjustment which exceeds the total float for the schedule path wherein the activity is located. The adjustment is only applicable during the time the delay occurred or when the change is ordered.

6.3 Time Impact Analysis shall be submitted in triplicate and within fifteen (15) days after a delay occurs or with the Contractor's cost proposal in response to a notice of change from the Construction Manager. In cases where the Contractor does not submit a Time Impact Analysis for a specific change order, delay, or other Contractor requested time extension within the specified period of time, then it is mutually agreed that the particular change order, delay, or Contractor request has no time impact on the Contract completion date and no time extension is required.

- a. Approval or rejection of Time Impact Analyses by the Construction Manager and the District will be made within fifteen (15) days after receipt of the Time Impact Analysis unless subsequent meetings and negotiations are necessary.
- b. Upon approval, a copy of the Time Impact Analysis signed by the Construction Manager and District will be returned to the Contractor.
- c. Upon mutual agreement by both parties, schedule revisions illustrating the influence of change orders, delays, and/or Contractor requests will be incorporated into the next schedule update.

7.0 WEEKLY ACTIVITIES PLAN

On the last working day of every week the Contractor shall submit to the Construction Manager the Contractor's Plan of Activities for the next three weeks. The Plan of Activities shall describe the activity and location of the activity and include the activity number as provided in the CPM Schedule.

***** END OF SECTION *****

SECTION 01340

SHOP DRAWINGS, PRODUCT DATA AND SAMPLES

1.0 SUBMITTALS

1.1 General

Where the Contractor is required by these Specifications to make submittals, they shall be made to the Construction Manager with a letter of transmittal and in accordance with the requirements of this section.

The Contractor shall submit to the Construction Manager. One (1) email copy of the following items listed immediately below unless other provisions of the Contract Document stipulate a different quantity. One (1) copy of submittals which require review will be returned to the Contractor with review comments, if any, noted. Reviewed copies of the construction schedule and the Final Operation and Maintenance Manuals will not be returned to the Contractor. It shall be the Contractor's responsibility to copy and/or conform reviewed submittals in sufficient numbers for its files, subcontractors, and vendors.

- Contractor's Representative
- Safety Program
- Safety Supervisor
- Designated "Competent Person(s)"
- Substitutions
- Shop Drawings
- Material Safety Data Sheets
- Operation and Maintenance Manuals
- Working Drawings
- Warranty Data
- Others as Specified in the Technical Specifications

1.2 Contractor's Responsibilities

The Contractor shall submit, at its own expense, submittals and details of structural and reinforcing steel, equipment, material, electrical controls, architectural fabrications, pipe, pipe joints, special pipe sections, and any other appurtenances as required in technical specifications.

All submittals and supporting data, catalogs, schedules, etc., shall be submitted as the instruments of the Contractor, who shall be responsible for their accuracy and completeness and coordination. Such responsibility shall not be delegated in whole or part to subcontractors or suppliers. These submittals may be prepared by the Contractor, subcontractors, or suppliers, but the Contractor shall ascertain that submittals meet all of the requirements of the Contract Documents, while conforming to structural, space, and access conditions at the point of installation. Designation of work "by others," if shown in submittals, shall mean that the work will be the responsibility of the Contractor rather than the subcontractor or supplier who prepared the submittals. The Contractor shall insure that there is no conflict with other submittals and notify the Construction Manager in each case where its submittal may affect the work of another contractor or the District. The Contractor shall insure coordination of submittals among the

related crafts and subcontractors. The Contractor accepts the responsibility and expense for additional costs and delays which may result from Work performed without favorably reviewed submittals.

Submittals shall be prepared in such form that data can be identified with the applicable Specification paragraph. The data shall clearly demonstrate compliance with the Contract Plans and Specifications and shall relate to the specific equipment to be furnished. Where manufacturer's standard drawings are employed, they shall be marked clearly to show what portion of the data is applicable to this project.

2.0 MATERIAL AND EQUIPMENT SUBSTITUTIONS

2.1 General

In preparing these Specifications, the Design Consultant has named those products, which to its knowledge meet the Specifications and are equivalent in construction, functional efficiency, and durability.

Wherever catalog numbers and specific brands or trade names preceded by "similar and equal" or followed by the designation "or equal" are used in conjunction with a designated material, product, thing, installation, or service mentioned in these Specifications, they are used to establish the standards of quality and utility required.

The first-named manufacturer is the basis for the project design and the use of alternative-named or unnamed manufacturer's products proposed by the Contractor may require modifications in the project design and construction. Where only one product has been named by brand, it is the only brand, trade name, or manufactured product known to the Design Consultant that meets these Specifications.

2.2 Substitutions

Substitutions which are equal in quality and utility to those specified will be permitted, subject to the following provisions. Sufficient data, drawings, samples, literature, calculations, or other detailed information as will demonstrate to the Design Consultant that the proposed substitute is equal in quality and utility to the material specified shall be appended to this list. The Design Consultant will favorably review in writing such proposed substitutions as are, in its opinion, equal in quality to the items or materials specified.

Insufficient product data and other related information which does not permit an informed evaluation is an adequate basis for rejection of the proposed substitution.

Failure of the Contractor to submit proposed substitutions for review in the manner described above shall be sufficient cause for rejection by the Construction Manager of any substitutions otherwise proposed.

2.3 Modifications and Costs

If alternative named or substitutions are proposed by the Contractor and favorably reviewed by the Design Consultant, the Contractor is responsible for providing, at no additional cost to the District, any electrical, mechanical, structural, or other related changes or testing that may be required to accommodate or provide the particular material or equipment the Contractor desires

to use. Any deviation from the Specifications or the Drawings resulting from the type of material or equipment to be used shall not be the basis for any "extra charges" above and in excess of the original bid price of the work.

In addition the Contractor is responsible for all additional costs to the District, and its agents and representatives, for evaluation of data submitted by the Contractor for alternative named or substitutions and any redesign necessary. The District shall deduct said costs from the Contract monies due the Contractor.

3.0 SUBMITTAL AND MATERIAL LIST

Within ten (10) days of the Notice of Award the District will provide the Contractor with a Preliminary List of anticipated submittals. This list is intended as a reference to assist the Contractor in the submittal process and may not include all submittals required by the Contract. Accordingly, the Contract requirements shall govern over the District provided Preliminary List. Within five (5) days after the Notice to Proceed and prior to the submission of the initial shop drawings, the Contractor shall submit a complete list of all required submittals to the Construction Manager for favorable review. The Submittal and Material List shall include a description of each item, Specification reference and the anticipated submittal date. The List shall include all items of equipment and materials for architectural, structural, mechanical, piping, electrical, heating and ventilating, equipment piping, and plumbing work; and the names of manufacturers with whom purchase orders have been placed. Items on the List shall be arranged in the same order as in these Specifications, and shall contain sufficient data to identify precisely the items of material and equipment the Contractor proposes to furnish. The List shall reference the applicable Specification section or Drawing. After the submission is favorably reviewed and returned to the Contractor by the Construction Manager, it shall become the basis for the submission of detailed manufacturer's drawings, catalog cuts, curves, diagrams, schematics, data, and information on each separate item for review. No work shall proceed on any item until it has been submitted and favorably reviewed. An incomplete submittal list is not a basis for avoiding a submittal required by the specifications.

4.0 TRANSMITTAL PROCEDURES

4.1 Transmittal Form

A separate transmittal form shall be used for each specific item, class of material, equipment, and items specified in separate, discrete sections, for which the submittal is required. Submittal documents common to more than one piece of equipment shall be identified with all the appropriate equipment numbers. Submittals for various items shall be made with a single form when the items taken together constitute a manufacturer's package or are so functionally related that expediency indicates checking or review of the group or package as a whole. The specification section and subsection or paragraph to which the submittal is related shall be indicated on the transmittal form.

A unique number, sequentially assigned, shall be noted on the transmittal form accompanying each item submitted. Original submittal numbers shall have the following format: "XXX"; where "XXX" is the sequential number assigned by the Contractor. Resubmittals shall have the following format: "XXX-Y"; where "XXX" is the originally assigned submittal number and "Y" is a sequential letter assigned for resubmittals, i.e., A, B, or C being the 1st, 2nd, and 3rd resubmittals, respectively. Submittal 25B, for example, is the second resubmittal of submittal 25.

4.2 **Deviations From The Contract**

If the submittals show any deviations from the Contract requirements, the Contractor shall submit with the submittal submission a separate written description of such deviations and the reasons therefor. If the Owner accepts such deviation, the District shall issue an appropriate Contract Change Order, except that, if the deviation is minor, or does not involve a change in price or in time of performance, a Change Order need not be issued. If any deviations from the Contract requirements are not noted on the submittal, the review of the shop drawing shall not constitute acceptance of such deviations.

4.3 **Submittal Completeness**

The Contractor shall review and check all submittals before submitting them to the Construction Manager. The Contractor shall stamp and certify on the transmittal letter and on each shop drawing that they have been checked, are in compliance with the Plans and Specifications, and all deviations from the Contract requirements are noted.

If the Contractor submits an incomplete submittal, the submittal will be returned to the Contractor without review. A complete submittal shall contain sufficient data to demonstrate that the items comply with the Specifications, shall meet the minimum requirements for submissions cited in the technical specifications, shall include materials and equipment data and seismic anchorage certifications where required, and shall include any necessary revisions required for equipment other than first named.

It is considered reasonable that the Contractor shall make a complete and acceptable submittal to the Construction Manager at least by the second submission of data. The District reserves the right to deduct monies from payments due the Contractor to cover additional costs of review beyond the second submission.

4.4 **Submittal Period**

The Contractor shall submit the intended schedule for submission of the major submittals as defined in Section 01310, **PROGRESS SCHEDULES**. Submittals shall be submitted in time to allow appropriate time for review and response to submittals as provided for herein prior to the incorporation of materials and equipment in the Work.

4.5 **Alternate Submittals**

If a submittal is approved and the Contractor elects to submit an alternate item for review for the same application, the Contractor shall be responsible for the review costs for the alternate submittal.

5.0 **REVIEW PROCEDURE**

Submittals shall be submitted to the Construction Manager for review and returned to the Contractor within 30 calendar days after receipt. When a submittal cannot be returned within this period, the Construction Manager will within a reasonable time after receipt of the submittal give notice of the date by which that submittal will be returned. Review of submittals by the Design Consultant has as its primary objective the completion for the District of a project in full conformance with the Contract Documents, unmarred by field corrections, and within the time provided.

After review by the Design Consultant of each of the Contractor's submissions, the material will be returned to the Contractor with actions defined as follows:

- A. **NO EXCEPTIONS NOTED** - Accepted subject to its compatibility with future submissions and additional partial submissions for portions of the work not covered in this submission. Does not constitute approval or deletion of specified or required items not shown in the partial submission.
- B. **MAKE CORRECTIONS NOTED (No resubmission required)** - Same as A, except that minor corrections as noted shall be made by the Contractor. Contractor shall provide partial resubmittal where required by the review comments.
- C. **AMEND & RESUBMIT** - Rejected because of major inconsistencies or errors which shall be resolved or corrected by the Contractor prior to subsequent review by the Design Consultant.
- D. **REJECTED - RESUBMIT** - Submitted material does not conform to Plans and Specifications in major respect. (i.e., wrong size, model, capacity, or material.)

Items A and B above (no resubmittal required) are considered "favorable review." Items C and D above (correction and resubmittal required) are considered "unfavorable review."

6.0 EFFECT OF REVIEW OF CONTRACTOR'S SUBMITTALS

The Design Consultant's favorable review of submittals shall be obtained prior to the fabrication, delivery and construction of items requiring submittal review.

The favorable review of all submittals by the Design Consultant shall apply in general design only and shall in no way relieve the Contractor from responsibility for errors or omissions contained therein. Favorable review by the Design Consultant shall not relieve the Contractor of its obligation to meet contractual requirements, safety requirements and all other requirements of laws, nor constitute a Contract Change Order. Favorable review will not constitute acceptance of any responsibility for the accuracy, coordination, and completeness of the submittals or the items of equipment represented on the submittals.

END OF SECTION

THIS PAGE INTENTIONALLY LEFT BLANK

SECTION 01400
QUALITY CONTROL

1.0 INSPECTION AND TESTING

Additional requirements for tests are described in other Technical Sections of these Specifications.

1.1 General

Where the Contract Documents require work to be field tested or approved, it shall be tested in the presence of the Construction Manager or its authorized representative. The Construction Manager shall have the right to witness all on-site tests performed by the Contractor and any shop tests. The results of any tests performed by the Contractor shall be made available for the information of the Construction Manager. Inspections, tests or favorable reviews by the Construction Manager or others shall not relieve the Contractor from its obligation to perform the work in accordance with the requirements of the Contract Documents or for its sole responsibility for the quality of workmanship and materials.

Except as specifically required under the technical specifications for testing and inspection, all tests for materials furnished by the Contractor will be done in accordance with commonly recognized standards of national organizations. Where tests are to be performed by the Construction Manager or by an independent laboratory or agency, the Contractor shall furnish such samples of all materials as required by the Construction Manager without charge. The sample or samples of materials to be tested shall be selected by such laboratory or agency, or the Construction Manager, and not by the Contractor. No material for which the Contract Documents require the submittal and approval of tests, certificates of compliance or other documentation shall be incorporated in the Work until such submittal has been made and approved.

The Contractor shall provide safe access for the Construction Manager and inspectors to adequately inspect the quality of work and the conformance with the Contract Documents. The Contractor shall furnish the Construction Manager the necessary labor and facilities for such things as excavation in the compacted fill to the depths required to take samples. The Contractor shall provide adequate lighting, ventilation, ladders and other protective facilities as may be necessary for the safe performance of inspections.

Upon completion of the Work the Construction Manager will conduct a final inspection as provided for in Section 00700-8.7, **Final Inspection and Payment**. Records shall be available at all reasonable hours for inspection by other local or State agencies to ascertain compliance with laws and regulations.

1.2 Notice

The Contractor shall notify the Construction Manager in writing at least 24 hours before any field testing or special inspections are required to be performed by the Construction Manager or independent laboratory furnished by the District. The Contractor shall notify the Construction Manager at least two hours before any inspection is required to be performed or to witness the Contractor's on-site field testing.

Whenever the Contractor varies the period during which work is carried on each day, the Contractor shall give due notice to the Construction Manager so that proper inspection may be provided. Any work done in the absence of the Construction Manager shall be considered to be rejected. It will be the responsibility of the Contractor to demonstrate to the satisfaction the Construction Manager that the work meets all conditions of the specification and if such conditions are not met to remove the work.

The Contractor shall give the Construction Manager written notification at least 30 days prior to the shipment of materials and equipment to be tested and/or inspected at the point of origin. Satisfactory tests and inspections at the point of origin shall not be construed as a final acceptance of the materials and equipment nor shall such tests and inspections preclude retesting or reinspection at the site of the Work.

1.3 **Costs of Testing**

1.3.1 The Contractor shall be responsible for, and shall pay for, all quality control and off-site tests of materials required including all source and mix design tests for the approval of soil and concrete materials. The District will perform the soils and concrete confirmation tests detailed in the Technical Specifications during the performance of the Work. District will retain and pay a qualified testing agency to perform soil compaction testing and work identified as requiring special inspections and testing as defined by UBC section 1701. All other testing required by the technical specifications shall be the responsibility of the Contractor.

1.3.2 The Contractor shall be responsible for, and shall pay for, all source quality control and all on-site tests of materials required, except those tests specifically noted to be performed and paid for by the District.

1.3.3 The Construction Manager shall have the authority to require additional tests or inspections due to the manner in which the Contractor executes its work. Examples of such additional tests and inspections include; tests of materials substituted for previously accepted materials, or substituted for specified materials, or retests made necessary by failure of material to comply with the requirements of the Specifications. Where such tests and inspections are required by Contract to be performed by the District, the District will pay for the additional tests and inspections but will issue an unilateral Change Order to deduct these costs from the Contract price.

1.4 **Work Covered Prior to Inspection and/or Testing**

Work requiring inspection and/or testing shall not be concealed or buried prior to the acceptance of such inspection or testing. Work covered without the favorable review or consent of the Construction Manager shall, if required by the Construction Manager, be uncovered for inspection and/or testing at the Contractor's expense.

1.5 **Work Covered With Prior Inspection and/or Testing**

If the Construction Manager considers it necessary or advisable that covered work which was favorably inspected and tested be uncovered for reinspection and/or retesting, the Contractor, at the Construction Manager's request, will uncover, expose or otherwise make available for observation, inspection or testing as the Construction Manager may require, that portion of the work in question, furnishing all necessary labor, materials, tools, and equipment. If it is found that such work is defective, the Contractor will bear all expenses of such uncovering, exposure,

observation, inspection and testing and of satisfactory reconstruction. If, however, such work is not found to be defective the Contractor will be allowed an increase in the Contract price or an extension of the Contract time, or both, directly attributable to such uncovering, exposure, observation, testing and reconstruction, and a Change Order shall be issued for such additional work.

2.0 TEST WATER

The Contractor shall furnish and dispose of the water which is required for testing of pipes and structures. The Contractor shall dispose of all testing water without damage to property, and in accordance with applicable regulations.

END OF SECTION

THIS PAGE INTENTIONALLY LEFT BLANK

SECTION 01510

TEMPORARY UTILITIES

1.0 ELECTRICAL SERVICE

The Contractor shall arrange, at its own cost, adequate temporary electrical service as may be necessary for the work.

2.0 WATER

The Contractor shall pay for and shall construct all facilities necessary to furnish water for its use during construction, including potable water service. Water used for human consumption shall be kept free from contamination and shall conform to the requirements of the State and local authorities for potable water. The Contractor shall pay for all water used for the Contractor's operations prior to final acceptance.

3.0 TEMPORARY LIGHTING

The Contractor shall provide temporary lighting in all work areas sufficient to maintain a lighting level not less than the lighting required by California OSHA standards.

4.0 NOT USED

5.0 SANITARY CONVENIENCES

The Contractor shall provide suitable and adequate sanitary conveniences for the use of all persons at the site of the Work, including sewer service. Such conveniences shall include chemical toilets and shall be located at appropriate locations at the site of the Work. All sanitary conveniences shall conform to the regulations of the public authority having jurisdiction over such matters. At the completion of the Work, all such sanitary conveniences shall be removed and the site left in a sanitary condition.

END OF SECTION

THIS PAGE INTENTIONALLY LEFT BLANK

SECTION 01560

TEMPORARY CONTROLS

1.0 TEMPORARY FACILITIES

Construction hoists, elevators, scaffolds, stages, shoring, and similar temporary facilities shall be of ample size and capacity to adequately support and move the loads to which they will be subjected. Railings, enclosures, safety devices, and controls required by law or for adequate protection of life and property shall be provided.

2.0 STAGING AND FALSEWORK

Temporary supports shall be designed by a registered professional engineer with an adequate safety factor to assure adequate seismic and load bearing capability. If requested by the Construction Manager, the Contractor shall submit design calculations for staging and shoring prior to application of loads.

Excavation support shall be in accordance with Section 00700-4.7, **Safety**.

3.0 PROTECTION OF WORK, PROPERTY AND PERSONS

The Contractor shall be responsible for the care of all work until its completion and final acceptance; and the Contractor shall, at its own expense, replace damaged or lost material and repair damaged parts of the Work, or the same may be done by the District, and the Contractor and its sureties shall be liable therefor. The Contractor shall make its own provisions for properly storing and protecting all material and equipment against theft, injury, or damage from any and all causes. Damaged material and equipment shall not be used in the Work. The Contractor shall take all risks from floods and casualties, or for delays from such causes. The Contractor may, however, be allowed a reasonable extension of time on account of such delays, subject to the conditions hereinbefore specified. The Contractor shall remove from the vicinity of the completed work all plant, buildings, rubbish, unused material, concrete forms, sheeting or equipment belonging to the Contractor or used under its discretion during construction; and in the event of the Contractor's failure to do so, the same may be removed by the District at the expense of the Contractor, and the Contractor and its sureties shall be liable therefor.

The Contractor will be held responsible for and be required to make restitution, at its own expense, for all damage to persons or property caused by the Contractor or subcontractor, or the agents, or employees of either during the progress of the Work and until its final acceptance.

4.0 FENCES

4.1 **Existing Fences**

All fences on private property which are temporarily removed or damaged shall be replaced as new or better condition than the original.

4.2 **Temporary Fences**

Except for trenches that are plated the Contractor shall provide temporary chain link fencing to protect equipment, materials and temporary facilities against acts of theft, violence, or vandalism.

5.0 **NOT USED**

6.0 **NOT USED**

7.0 **WORKING HOURS**

Working hours are shown on the Contract Plans.

When approved in advance by the District, work on weekends or holidays will conform to the following hours, unless otherwise approved by the District. Work on weekends and holidays may or may not be approved at the District's sole discretion. The Contractor shall request permission in writing from the Construction Manager at least 24 hours prior to any work to be performed outside the normal working hours defined above, on weekends or holidays.

The Contractor shall be responsible for any inspection and additional administration costs incurred by the District, or its agents and representatives for the following conditions:

- A. For work by the Contractor outside the hours defined above on weekdays, or any work on weekends or holidays recognized by the District.
- B. For overtime costs beyond ten (10) hours in any one workday shift, regardless if the ten (10) hours occur in the allowed working hours.

Such costs shall be withheld from the succeeding monthly progress payment. Any work in Section 01010, **SUMMARY OF WORK**, specifically required to be performed outside the normal working hours is excluded from the provisions of this paragraph and shall not be outside the hours stated above.

8.0 **DUST CONTROL**

During the performance of all work under this Contract, the Contractor shall assume all responsibility for dust control and shall furnish all labor, equipment, and means required to carry out proper and efficient measures wherever and whenever dust control is necessary to prevent the Contractor's operations from producing dust damage and nuisance to persons and property. Unless the construction dictates otherwise, and unless otherwise approved by the Construction Manager, the Contractor shall furnish and operate a self-loading motor sweeper with spray nozzle at least once each working day to keep paved areas acceptably clean whenever construction, including restoration, is incomplete.

Any claims resulting from dust damage or nuisance shall be borne solely by the Contractor.

9.0 **FIRE EXTINGUISHER**

Sufficient number of fire extinguishers of the type and capacity required to protect the Work and ancillary facilities, shall be provided and maintained by the Contractor in readily accessible locations.

10.0 USE OF EXPLOSIVES

Use of explosives will not be permitted.

11.0 REMOVED MATERIALS

All concrete, paving, reinforcing steel, fencing materials, rock, soil, strips, and other waste material and construction debris shall be removed from the site by the Contractor and disposed of in accordance with applicable regulations and laws.

12.0 CONSTRUCTION CLEANING

Throughout the period of construction the Contractor shall keep the Work site; including work, storage, parking, and employee areas; free and clean of all rubbish and debris, and shall promptly remove from the site, or from property adjacent to the site of the Work, all unused and rejected materials, surplus earth, concrete, plaster, and debris. In particular the Contractor shall keep the site clean to maintain safe access and to avoid fire hazard.

13.0 NOISE ABATEMENT

Operations at the Worksite shall be performed so as to minimize unnecessary noise. Special measures shall be taken to suppress noise during night hours. Noise levels due to construction activity shall not exceed as specified by local ordinance.

Internal combustion engines used on the Work shall be equipped with a muffler of a type recommended by the manufacturer. No internal combustion engine shall be operated without said muffler.

14.0 DRAINAGE CONTROL

In excavation, fill, and grading operations care shall be taken to disturb the pre-existing drainage pattern as little as possible. Particular care shall be taken not to direct drainage water onto private property or into streets or drainage ways inadequate for the increase flow. Drainage means shall be provided to protect the Work.

15.0 STORM WATER QUALITY CONTROLS

15.1 Regulatory Requirements

- A. The Contractor shall comply with the SWRCB, RWQCB, County, City, and other local agency requirements regarding stormwater management, inspection, and monitoring.
- B. Construction activities are regulated under the National Pollutant Discharge Elimination System (NPDES) General Permit for Storm Water Discharges Associated with Construction Activity (General Permit). The appropriate Regional Water Quality Control Board (RWQCB) enforces the General Permit. Coverage under a General Permit requires the submission of a Notice of Intent (NOI) and a Notice of Termination (NOT) and the preparation of a SWPPP.

- C. The Contractor shall comply with the following prohibitions and limitations, which are contained in the Stormwater Permit:
1. Discharge prohibitions:
 - a. Discharges of materials other than stormwater, which are not otherwise regulated by a NPDES permit, to a separate stormwater sewer system or water of the nation are prohibited.
 - b. Stormwater discharges shall not cause or threaten to cause pollution, contamination (including sediment) or nuisance.
 - c. Stormwater discharges regulated by this General Permit shall not contain a hazardous substance equal to or in excess of a reportable quantity listed in 40 CFR Part 117 and 40 CFR Part 302.
 2. Receiving Water Limitations:
 - a. Stormwater discharges to any surface or groundwater shall not adversely impact human health or the environment.
 - b. Stormwater discharge shall not cause or contribute to a violation of any applicable water quality standards contained in the California Ocean Plan, Inland Surface Waters and Enclosed Bays and Estuaries Plan, or the applicable Regional Water Board's Basin Plan.

15.2 **General**

The District will be responsible to the RWQCB for causing the preparation of and compliance with the various management plans called for by the RWQCB. The Contractor is responsible for providing the detail planning and compliance activities insofar as they would potentially affect the Contractor's methods and means of performing the Work.

If a violation of the Permit is due to the Contractor's actions or inactions and a fine is assessed, the Contractor shall be responsible for the fine and all applicable remediation requirements.

15.3 **Contractor Responsibilities**

- A. The Contractor shall be responsible for meeting the requirements of the General Permit except as specifically noted otherwise within this Section.
- B. The Contractor shall prepare a Stormwater Pollution Prevention Plan (SWPPP) and be fully responsible for following BMPs as described in the State of California's Water Resources Control Board Website, www.swrcb.ca.gov. Prior to soil disturbing work the Contractor shall submit the SWPPP and a compliance plan showing how it intends to comply with and monitor the effectiveness of the SWPPP. The Contractor shall not perform any clearing and grubbing or earthwork on the project until the SWPPP and compliance plan are submitted and accepted by the Construction Manager. The required SWPPP measures shall be implemented concurrently with, or prior to, the commencement of soil disturbing work.
- C. The Contractor shall prepare and submit to the Construction Manager the annual updates and certification to the SWPPP as identified in Section B, Item 4- Compliance Certification, of the General Permit.
- D. The Contractor shall provide evidence to the Construction Manager that the individual(s) responsible for the SWPPP preparation, implementation, and permit

compliance have been appropriately trained and have attended training and/or workshops offered by the SWRCB, RWQCB, or other locally recognized agencies or professional organizations in accordance with Section A, Item 12-Training, of the General Permit.

- E. Contractor shall provide names and 24-hour phone numbers for parties responsible for implementing, monitoring, inspecting and maintaining the SWPPP.
- F. Contractor shall be responsible for implementing, monitoring, inspecting, and maintaining best management practices (BMPs) Section A, Storm Water Pollution Prevention Plan, of the General Permit.
- G. Contractor shall be responsible for providing equipment, materials, and workers to implement SWPPP as well as being available for rapid response to BMP failures and emergencies.
- H. The entire plan shall be kept and maintained by the Contractor on the construction site during the duration of the project.
- I. The Contractor shall be responsible for taking the proper actions to prevent stormwater coming into contact with contaminants and sediments from migrating offsite or entering storm sewer drainage systems. The Contractor shall take immediate action if directed by the Construction Manager or if the Contractor observes contaminants and/or sediments entering the storm drainage system, to prevent further stormwater from entering the system.
- J. The Contractor shall update the SWPPP whenever there is a change in construction or operations which may affect the discharge of pollutants to storm water.
- K. The SWPPP shall also be amended if it is in violation of any conditions of the General Permit or has not achieved the general objective of reducing pollutants in storm water discharges.
- L. All amendments shall be completed at no additional cost to the District.

16.0 WARNING DEVICES AND BARRICADES

The Contractor shall adequately identify and guard all hazardous areas and conditions by visual warning devices and, where necessary, physical barriers. Such devices shall, as a minimum, conform to the requirements of Cal/OSHA.

17.0 TRAFFIC REGULATIONS

17.1 General

The Contractor shall take all necessary steps to minimize inconvenience to the general public throughout all work under this Contract. No driveways or private roads shall be blocked without notifying the property owner and access must be restored during all non-working hours. Safe access must be maintained for pedestrian traffic throughout the work area at all times.

At least one lane of traffic in each direction must be kept open at all times unless prior approval is provided by the District and the Public Agency, which has authority for the right-of-way. No

roads shall be blocked or made inaccessible, due to the Contractor's work, without prior written approval of the District and the affected agencies. More stringent requirements may be imposed in the right-of-way permits.

The Contractor shall not block or obstruct fire lanes at any time.

The Contractor shall adopt all practical means to minimize interference to traffic and inconvenience, discomfort, or damage. The Contractor shall protect against damage, any piling, duct or structures crossing trenching or encountered in the work and shall be responsible for any damage done to such structures or damage therefrom. The Contractor shall support or replace any such structures without delay and without any additional compensation, to the entire satisfaction of the Construction Manager. All obstructions to traffic shall be guarded by flagmen as required and by barriers and illuminated at night. The Contractor shall be responsible for all damage to persons and property directly or indirectly caused by its operations, and under all circumstances the Contractor shall comply with the regulations of the City or County, and the laws and regulations of the State of California, relative to safety of persons and property and the interruption of traffic and the convenience of the public within the respective jurisdiction, and the Contractor shall be solely responsible for any damages caused by failure to provide proper safety.

17.2 **Haul Routes**

In addition to any haul routes designated in the Contract Documents, at the preconstruction conference the Contractor shall furnish evidence that the Public Agency which has authority for the right-of-ways proposed to be utilized by the Contractor for haul routes has approved the proposed route(s) for all construction traffic on the Project. Upon approval, the Contractor shall strictly adhere to that route(s) only, unless written permission is obtained from such Public Agency to change the route(s).

17.3 **Traffic Control**

Traffic control shall be in accordance with the California Department of Transportation Traffic Manual. The Contractor shall submit for approval, by the District and any other applicable agency, its traffic control plans prior to work on public streets.

Traffic control shall include signs, warning lights, reflectors, barriers, and other necessary safety devices and measures, including sufficient flaggers to direct vehicular traffic through the construction areas.

No material or equipment shall be stored/parked where it will interfere with the free and safe passage of public traffic, and at the end of each day's work, and at other times when construction operations are suspended for any reason, the Contractor shall remove all equipment and other obstructions from the public right-of-way.

Should the Contractor appear to be negligent in furnishing warning and protective measures, as above provided, the Construction Manager or representative permitting agency may direct attention to the existence of a hazard, and the necessary warning and protective measures shall be furnished and installed by the Contractor at its expense.

18.0 ROADS AND FENCES

Roads subject to interference by the prosecution of the work covered by this Contract shall be

kept open, and fences subject to interference shall be maintained by the Contractor during the Work and shall be replaced to their original condition unless specifically shown otherwise on the Drawings. Such signs and barricades as are required by local laws and as necessary for the safe prosecution of the Work shall be provided.

Excavated dirt shall not be stored on roads, paths, or planted areas. Care shall be taken to protect improvements.

19.0 PARKING AND STAGING AREAS

Contractor parking and staging within the Project area shall only be allowed within the areas, if any, designated for such use by the District. These areas are shown on the Project Drawings.

20.0 TREES AND SHRUBS

Except as noted on the plans, the Contractor shall not remove trees or shrubs without authorization of the Construction Manager. Injuries to tree roots and limbs shall be avoided. No roots shall be cut or limbs pruned, without prior notification to and review of Contractors proposed methods by the Construction Manager.

END OF SECTION

THIS PAGE INTENTIONALLY LEFT BLANK

SECTION 01601

MATERIALS AND EQUIPMENT

1.01 GENERAL

The Contractor shall qualify all items proposed to be furnished, furnish operating and maintenance data, and protect, install, test and commission all materials and equipment as specified herein below.

1.02 EQUIPMENT, MATERIALS AND/OR PRODUCTS TO BE FURNISHED

The work, unless otherwise permitted or approved by the District, shall be completed with the incorporated use of equipment, materials and/or products where such are specified. Substitutions and equal alternatives will be permitted as provided in this article; however, neither the request for substitution nor the offer of alternatives shall in any way by their submittal obligate the District to assent to any request or offer. Failure of the Contractor awarded the work to either submit requests for substitutions or to offer alternatives within the required times provided in this General Condition will be considered as evidence that the work shall be accomplished with trade-named equipment, materials and/or products as identified in the Technical Provisions and/or the Project Drawings.

Unless otherwise provided elsewhere in the Contract, all equipment, materials and/or products incorporated into the work shall be new and, where not specified, shall be of the highest quality of the respective kinds for the intended use, and all installation shall meet or exceed applicable construction industry standards and practices. If equipment, materials and/or products are designated by listing named manufacturers of particular equipment, materials and/or products followed by the words "or equal," then the Contractor may furnish the named equipment, materials and/or products or any equal equipment, materials and/or products. The first named manufacturer of particular equipment, materials and/or products is the basis for the design shown on the Project Drawings. A subsequently named manufacturer or particular equipment, materials and/or products has been determined to be an acceptable substitution but may require modifications in the Project's design and its ultimate construction to accommodate its use. If such subsequently named items are selected by the Contractor for incorporation into the work, the Contractor shall assume all costs required for modifications to the equipment, materials and/or products, and the Project design and construction as may be required for said items' use. Substitutions for an unnamed "equal" item of material shall be permitted upon compliance with the procedures set forth herein. If a Contractor makes use of an unnamed "equal" product as a substitute for a specifically named material or product, the Contractor shall assume all costs required to make the necessary revisions or modifications to accommodate the use of said unnamed product.

Before beginning the work and as soon as possible after award of the Contract, the Contractor shall submit a List of Materials to the District for review. The List shall include all items of equipment, materials and/or products to be incorporated into the work and the names of suppliers with whom purchase orders have been placed. The names on the List shall be arranged in the same order as in the specifications, and shall contain sufficient data to identify precisely the items of equipment, materials and/or products the Contractor proposes to furnish. The List shall include specification or Project Drawing

references. Once the submission is determined to be acceptable to the District, it shall be returned to the Contractor.

If required by the District, the Contractor shall furnish sample specimens of materials proposed to be furnished.

1.03 SUBSTITUTIONS

Substitution for those equipment, materials and/or products specified shall only be permitted when the proposed unnamed "equal" product or material to be furnished is both equal in quality and utility and after the Contractor has complied with the following provisions: (1) All substitutions shall be reviewed by the District. (2) The District must approve such substitution in writing prior to its incorporation into the work. (3) Unless otherwise authorized in writing by the District, the Contractor shall, prior to award and placing any purchase orders, and at least thirty (30) calendar days before it requires approval of any such alternative item, submit to the District sufficient data, drawings, samples, literature, or other detailed information as will demonstrate to the District that the proposed substitute is equal in quality and utility to the equipment, materials and/or products specified.

Within thirty (30) calendar days following receipt of all requested information from the Contractor, the District will determine whether the proposed alternative is equal in quality and utility and meets the requirements of the Contract and will inform the Contractor in writing of such determination. The burden of substantiating the quality and utility of alternatives shall be upon the Contractor, and the Contractor shall furnish all necessary information requested and required by the District. The District will be the sole judge as to the quality and utility of alternative equipment, materials and/or products, and the District's decision shall be final. An acceptance by the District of a substitution shall not relieve the Contractor from complying with the requirements of the Project Drawings and Specifications. Acceptance by the District shall not relieve the Contractor from full responsibility for the efficiency, sufficiency and quality and performance of the substitute equipment, materials and/or products, in the same manner and degree as the equipment, materials and/or products specified by name.

Failure of the Contractor to submit proposed substitutions for review in the manner described above and within the time prescribed shall be sufficient cause for rejection by the District of any other proposed substitutions.

In determining whether a proposed product is equal in quality and utility, the District is not restricted to such basic issues as performance and durability, but may consider any other issues that the District, in the discretion of the District, deems appropriate. Said issues may, but are not required to include, nor are they limited to, such additional factors as comparable performance, reliability, efficiency of operation, ease of operation, adaptability, ease of maintenance, capital costs, life-cycle costs, operational characteristics, costs of training personnel, maintenance history, warranties, problems created by the resulting overall warranty system, availability of qualified service, availability of parts, the history of any supplier, and compatibility with existing facilities.

No one factor or group of factors, including such issues as savings on capital costs, shall be determinative of whether the proposed product or material is equal in quality and utility. The decision of the District shall be based on those factors deemed by the District

to be relevant and any data, drawings, samples, literature or other detailed information furnished by the Contractor with respect to the proposed substitution.

Each decision as to whether a product or material is equal in quality and utility shall be made by the District on a case-by-case basis.

The Contractor shall be responsible for any and all costs, including consultant costs, incurred by the District with respect to the proposed substitution that exceed the costs inherent in the normal and reasonable review of drawings and other standard data, information and documents concerning any proposed substitution. The Contractor shall be responsible for this cost, regardless of whether or not the substitution is approved by the District.

1.04 SUBMITTAL AND REVIEW PROCEDURE

A. GENERAL

The Contractor shall submit drawings and information describing materials or equipment in sufficient detail to determine whether the materials or equipment conform to the specifications in accordance with these instructions. The contractor may request a numbered list of the required submittals and submittal instructions. Unless otherwise indicated, all submittals required shall be furnished to the District within twenty (20) calendar days after the date of the Notice to Proceed. All copies of all submittals shall be accompanied by its own transmittal form sheet that includes all of the following information:

1. Project Name
2. Owner's Project or Contract Number
3. Engineer's Project Number
4. Submittal Date
5. Submittal Subject or Title
6. Supplier and/or Manufacturer
7. Submittal Item Number (see table below)
8. Specification Section, Page No. and Plan Sheet References
9. Submittal Revision Number
10. Submittal Preparers Name and Contact Information

Submitting via email: the Contractor shall contact the Administrative Assistant at (415) 453-4480 for the distribution list and email addresses. The Contractor shall submit to the District all submittals, each with its own complete transmittal form and, in the case of material to be tested, samples of the specified quantity each with its own completed transmittal.

Submittals prepared and submitted in accordance with these instructions will be deemed complete and will be processed. Incomplete submittals will be returned without comment. The Contractor shall submit packages for each of the items listed below, each with their own transmittal sheets and number for each of the submittals.

The following is a preliminary list and actual required submittals for this project may not be limited to those above including and in addition to changes per Addenda and official Contract Change Orders that are not shown on this list and additional items as requested by the Engineer. The Engineer may send out a letter with additional submittal items and supplemental submittal instructions.

1. Contractors Work Schedule
2. Shoring Plan
3. Water Pollution Control Plan / SWPPP
4. Contractors Safety Plan
5. Aggregate Base and Drain Rock
6. Contractors Traffic Control Plan for Daytime Construction
7. Permanent Pavement Markings
8. AC Paving Materials and Mixes
9. Concrete Mixes: Manhole Bases & Collars, Sidewalks, Curbs and Gutters, etc.
10. Water Stop, Ramnek
11. Manholes and Manhole Castings
12. Rodhole Collar Rebar
13. Rodhole Castings
14. All Pipe to be used on the job
15. HDPE Electrofusion Saddles, Fittings and Couplings
16. Two-Way Cleanouts, Riser and Relief Valve
17. Cleanout Boxes and CI Lids for Cleanouts
18. City Enroachment Permit and Conditions
19. County Enroachment Permit and Conditions
20. One Complete As-Built Plan Set (due prior to Notice of Completion)

When prior submittal is required, the Contractor shall submit to the District six (6) copies of the specified information or, in the case of material to be tested, samples of the specified quantity. After review of the submittal, the District shall return one (1) marked-up copy indicating one of the following actions:

1. If the review indicates that the material, equipment or work method is in general conformance with the design concept and complies with the drawings and specifications, submittal copies will be marked "NO EXCEPTIONS TAKEN." In this event, the Contractor may begin immediately to implement the work method or incorporate the material or equipment covered by the submittal.
2. If the review indicated limited corrections are required, copies will be marked "MAKE CORRECTIONS NOTED." The Contractor may immediately begin implementing the work method or incorporating the material and equipment covered by the submittal in accordance with the noted corrections.
3. If the review reveals that the submittal is insufficient or contains incorrect data, copies will be marked "REVISE AND RESUBMIT." Except at his/her own risk, the Contractor shall not undertake work covered by this submittal until it has been

revised, resubmitted and returned marked either "NO EXCEPTIONS TAKEN" or "MAKE CORRECTIONS NOTED."

4. If the review indicates that the material, equipment or work method is not in general conformance with the design concept or in compliance with the drawings and specifications, copies of the submittal will be marked "REJECTED - SEE REMARKS." Submittals with deviations which have not been identified clearly may be rejected. Except at his/her own risk, the Contractor shall not undertake work covered by such submittals until a new submittal is made and returned marked either "NO EXCEPTIONS TAKEN" or "MAKE CORRECTIONS NOTED."

In reviewing the submittals, the District is checking only for general conformance with the design concept of the project and general compliance with the information given in the Contract Documents. Any action shown is subject to the requirements of the plans and specifications. The Contractor shall be responsible for dimensions which shall be confirmed and correlated at the job site: fabrication processes and techniques of construction; coordination of the work with that of all other trades; and satisfactory performance of the work.

The Contractor agrees that shop drawing submittals processed by the District are not Change Orders; that the purpose of shop drawing submittals by the Contractor is to demonstrate to the District that he/she understands the design concept, that the Contractor demonstrates his/her understanding by indicating which equipment and material he/she intends to furnish and install and by detailing the proposed fabrication and installation methods. The Contractor further agrees that if deviations, discrepancies or conflicts between shop drawing submittals and the Contract Documents in the form of design drawings and specifications are discovered either prior to or after shop drawing submittals are processed by the District, the design drawings and specifications shall control and shall be followed.

B. CONTRACTOR'S PROCEDURE

The Contractor shall verify that the materials or equipment described in each submittal conform to all requirements of the specifications and drawings. Where the detailed specifications require specific submittal data, all data shall be submitted at the same time. The submittals shall be accompanied by a transmittal form, in sextuplet, septuplet for electrical submittals. If the submittal involves equipment driven by an electric motor, six copies of the motor data submittal sheet shall also be included (seven copies for electrical submittals) with the submittal package. The District will return for re-submittal any information not accompanied by the specified transmittal form, properly completed. The Contractor shall provide the required number of transmittal forms.

The Contractor may authorize a material or equipment supplier to deal directly with the District with regard to a submittal. Such authorization shall be in writing by the Contractor, with a copy directed to the District, and shall state that the supplier is in fact a bona fide supplier, under contract to the Contractor or one of his/her subcontractors. Such dealings will be for the purpose of interpretations of contract requirements and shall not be construed as irrevocable commitments on the part of the District. All written communications with the District shall be directed through the Contractor.

A separate transmittal form shall be used for each specific item or class of material or equipment for which a submittal is required. Submittals on various items using a single transmittal form will be permitted only when the items taken together constitute a manufacturer's "package" or are so functionally related that expediency indicates checking or review of the group or "package" as a whole.

C. EFFECT OF ACCEPTANCE OF CONTRACTOR'S INFORMATION

Acceptance by District of any drawings, method of work, or any information regarding materials or equipment the Contractor proposes to provide, shall not relieve the Contractor of his/her responsibility for any errors therein and shall not be regarded as an assumption of risks or liability by the District, or by any officer or employee thereof, and the Contractor shall have no claim under the contract on account of the failure or partial failure or inefficiency or insufficiency of any plan or method or work or materials or equipment so accepted. Such acceptance shall be considered to mean merely that the District has no objection to the Contractor using, upon his/her own full responsibility, the plan or method of work proposed, or providing the materials or equipment proposed.

D. DEVIATIONS FROM CONTRACT

If the Contractor proposes to provide material or equipment which does not conform to all of the specifications and drawings, the transmittal form accompanying the submittal copies shall indicate under "comments" the deviations and shall request a Change Order to cover the deviations.

1.05 PROTECTION OF MATERIALS AND EQUIPMENT

A. GENERAL

The Contractor shall be responsible for the materials and equipment included in this contract until it has been finally inspected, tested and accepted in accordance with the requirements of these specifications. The Contractor shall make his/her own provisions for properly storing and protecting all material and equipment against theft, injury or damage from any and all causes. Materials and equipment shall be shipped, handled, stored and installed by methods which will prevent damage to the items. Damaged items will not be permitted as part of the work except in cases of minor damage that have been satisfactorily repaired and are acceptable to the District.

B. PIPE

Pipe and appurtenances shall be handled, stored and installed as recommended by the manufacturer. Pipes with soft coatings such as coal tar enamel, paint or the like shall be stored to protect the coating from physical damage or other deterioration and shall only be handled with padded, wide slings. Pipes shipped with interior bracing shall have the bracing removed only when recommended by the pipe manufacturer.

C. DELIVERY OF MATERIAL OR EQUIPMENT

The District's personnel or representatives of the District will not accept materials or equipment deliveries for the Contractor.

1.06 INSTALLATION

All materials and equipment shall be installed in accordance with the manufacturer's recommendations and requirements.

All materials and equipment shall be installed by specialists properly skilled in the trades and professions required to assure first-class installation. Where required by detailed specifications, the Contractor shall cause the installation of specific equipment items to be accomplished under the supervision of factory-trained installation specialists furnished by equipment manufacturers. The Contractor shall be prepared to document the skills and training of all workers engaged in the installation of all equipment furnished by the Contractor or the District.

1.07 DEFECTIVE MATERIALS TO BE REMOVED

All materials not conforming to the requirements of these Specifications shall be considered as defective; and all such materials, whether in place or not, shall be rejected and shall be removed immediately from the site of the work.

1.08 RECORD DRAWINGS

The Contractor shall maintain at the site a set of drawings on which shall be accurately shown the actual installation of all work under this section, indicating thereon any variations from contract drawings, including any changes in sizes, locations and dimensions. For this purpose, the District will furnish two (2) sets of blue or black line on white prints.

The District may periodically inspect the record drawings at the site. The proper and current maintenance of the information required on these drawings shall be a condition precedent to approval of requisitions for periodic payment.

At the completion of the work, the Contractor shall submit a complete set of record drawings to the District.

1.09 WARRANTIES

The Contractor shall provide warranties on all labor and materials effective for one (1) year after the date of the project acceptance. Warranties shall be in favor of the Sanitary District.

END OF SECTION

THIS PAGE INTENTIONALLY LEFT BLANK

SECTION 01720

PROJECT RECORD DOCUMENTS

1.0 RECORD DOCUMENTS

- 1.1 Maintain at the Project site, available to the District and Construction Manager, one (1) copy of the Contract Documents, shop drawings and other submittals, in good order.
- A. Mark and record field changes and detailed information contained in submittals and change orders.
 - B. Record actual depths, horizontal and vertical location of underground pipes, duct banks and other buried utilities. Reference dimensions to permanent surface features.
 - C. Identify specific details of pipe connections, location of existing buried features located during excavation, and the final locations of piping, equipment, electrical conduits, manholes, and pull boxes.
 - D. Identify location of spare conduits including beginning, ending and routing through pull boxes, and manholes. Record spare conductors, including number and size, within spare conduits, and filled conduits.
 - E. Provide schedules, lists, layout drawings, and wiring diagrams.
 - F. Make annotations with erasable colored pencil conforming to the following color code:

Additions:	Red
Deletions:	Green
Comments	Blue
Dimensions:	Graphite

- 1.2 Maintain documents separate from those used for construction. Label documents "RECORD DOCUMENTS."
- 1.3 Record Documents shall be updated at least once each week and shall be available to the Construction Manager for review. Keep documents current. Record required information at the time the material and equipment is installed and before permanently concealing.
- 1.4 Deliver Record Documents with transmittal letter containing date, Project title, Contractor's name and address, list of documents, and signature of Contractor prior to request for Final Payment.
- 1.5 Record documents shall be available for the Construction Manager to review to ascertain that changes have been recorded.
- 1.6 **Failure of the Contractor to keep current with the updating of the Record Documents shall be grounds for withholding monies from partial payment estimates as specified in Section 00700-8.3.2, Other Withholds.**

END OF SECTION

THIS PAGE INTENTIONALLY LEFT BLANK

SECTION 01740

WARRANTIES AND BONDS

1.0 GUARANTEE OF WORK

The Contractor hereby agrees to make, at its own expense, all repairs or replacements necessitated by defects in materials or workmanship, supplied under terms of this Contract, and pay for any damage to other works resulting from such defects, which becomes evident within one (1) year after the date of acceptance of the project or the Substantial Completion date whichever is applicable or within such longer period of time as may be prescribed by law or by the terms of any applicable special guarantee required by the Contract Documents. The Contractor further assumes responsibility for a similar guarantee for all work and materials provided by subcontractors or manufacturers of packaged equipment components. The Contractor also agrees to indemnify, defend, and hold the District harmless from liability of any kind arising from damage due to said defects.

The Contractor shall execute and submit a completed Warranty Form in the format as appended to this section for the Work, and any portion of the Work possessed in accordance with Paragraph 00700-3.4, **District's Right to Use or Occupy**. The Warranty Form shall be submitted prior to the Substantial Completion date or the final acceptance of the project or within five (5) days of the occupancy or use of a portion of the Work, whichever is applicable. In addition the Contractor shall submit the other specified additional warranties, guarantees, and bonds from manufacturers and suppliers.

The Contractor shall, upon the receipt of notice in writing from the District, promptly make all repairs arising out of defective materials, workmanship, or equipment. The District is hereby authorized to make such repairs, and the Contractor and its Surety shall be liable for the cost thereof, if ten (10) days after giving of such notice to the Contractor, the Contractor has failed to make or undertake the repairs with due diligence. In case of emergency, where in the opinion of the District delay could cause serious loss or damage, repairs may be made without notice being sent to the Contractor, and the expense in connection therewith shall be charged to the Contractor, and its Surety shall be liable for the cost thereof.

Prior to the expiration of the Warranty period, the District reserves the right to hold a meeting and require the attendance of the Contractor. The purpose of the meeting is to review warranties, bonds and maintenance requirements and determine required repair or replacement of defective items.

For the purpose of this paragraph, acceptance of the Work or a portion of the Work by the District, shall not extinguish any covenant or agreement on the part of the Contractor to be performed or fulfilled under this Contract which has not, in fact, been performed or fulfilled at the time of such acceptance. All covenants and agreements shall continue to be binding on the Contractor until they have been fulfilled.

The District and the Contractor agree that warranty on the parts of the work possessed and used by the District in accordance with Paragraph 00700-3.4, **District's Right to Use or Occupy**, shall commence on the date that the District takes possession of such work and so notifies the Contractor in writing. The District and the Contractor further agree that such possession, and use of the work shall not be deemed as Substantial Completion or acceptance of any other part of the Work.

If, after installation, the operation or use of the materials or equipment furnished under this Contract proves to be unsatisfactory to the Construction Manager or District, the District shall have the right to operate and use such materials or equipment until it can, without damage to the District, be taken out of service for correction or replacement. Such period of use of the defective materials or equipment pending correction or replacement shall in no way decrease the guarantee period required for the acceptable corrected or replaced items of materials or equipment.

Nothing in this Section shall be construed to limit, relieve or release the Contractor's, subcontractor's and equipment supplier's liability to the District for damages sustained as the result of latent defects in the equipment furnished caused by the negligence of the supplier's agents, employees or subcontractors. Stated in another manner, the warranty contained in this Section shall not amount to nor shall it be deemed to be a waiver by the District of any rights or remedies (or time limits in which to enforce such rights or remedies) it may have against the supplier of the equipment to be furnished under these Specifications for defective workmanship or defective materials under the laws of this State pertaining to acts of negligence.

WARRANTY FORM

Warranty For

Sanitary District No. 5

**2022 Sewer Rehabilitation Project
Tiburon and Belvedere**

We hereby guarantee the (Project/Component) that we have constructed for a period of one (1) year from (Date) the date of acceptance of the work/substantial completion by the Sanitary District No.5.

The following are excluded from the provisions of this warranty:

We agree that if any of the equipment should fail due to any reason other than improper maintenance or improper operation, if any pipe or appurtenances should develop leakage, or if any settlement of fill or backfill occurs, or should any portion of the work fail to fulfill any of the requirements of the Specifications, we will, within ten days after written notice of such defects, commence to repair or replace the same together with any other work which may be damaged or displaced in so doing.

In the event of our failure to comply with the above with the above mentioned conditions within a reasonable time after being notified, or should the exigencies of the case require repairs or replacements to be made before we can be notified or respond to notification, we do hereby authorize the Sanitary District No. 5 to proceed to have the defect repaired and made good at our expense, and we will pay the cost therefor upon demand.

The warranty provided herein shall not be in lieu of, but shall be in addition to any warranties or other obligations otherwise imposed by the Contract Documents and by law.

Contractor: _____

Signed: _____

Titled: _____

Date: _____

END OF SECTION

THIS PAGE INTENTIONALLY LEFT BLANK

SECTION 02055

DEMOLITION AND ABANDONMENT OF PIPELINES AND STRUCTURES

PART 1 - GENERAL

1.01 DESCRIPTION

A. SCOPE OF WORK

The Contractor shall abandon certain pipelines and structures as shown on the plans and as specified.

B. RELATED WORK SPECIFIED IN OTHER TECHNICAL SECTIONS

1. Section 02200: Excavation and Backfill
2. Section 02500: Surface Restoration

1.02 SAFETY

The Contractor shall take all necessary precautions with regard to safety in carrying out the demolition and abandonment work. Suitable barriers shall be erected around the demolition area to protect workmen and the public, and the Contractor shall rigorously comply with applicable safety requirements.

1.03 PAYMENT

The cost of all demolition, abandonment and disposal of materials and debris shall be included in the various bid prices therefor and no additional compensation will be allowed.

PART 2 - PRODUCTS

2.01 GROUT

- A. The grout materials shall consist of Portland cement (Portland cement and fly ash) and/or additives. The grout shall have a minimum penetration resistance of 100 psi in 24 hours when tested in accordance with ASTM C403 and a minimum compressive strength of 200 psi in 7 days when tested in accordance with ASTM C495 and a compressive strength of 300 psi in 28 days when tested in accordance with ASTM C495.
- B. The Contractor shall design a grout mix with a density to meet the requirements of ASTM C939. The apparent viscosity shall not exceed 18 seconds in accordance with ASTM C939. The grout shall not bleed or segregate.
- C. The initial set time shall not be less than 3 hours. The grout shall have a minimum density of 55 pcf and a maximum density of 61 pcf. The grout shall have less than 1 percent shrinkage by volume.

PART 3 - EXECUTION

3.01 SALVAGE OF MATERIALS

No materials shall be salvaged. All removed and/or demolished materials resulting from project construction activities shall become the sole property of the contractor.

3.02 METHODS AND EQUIPMENT

Before starting work, the Contractor shall inform the District fully as to the method of demolition he/she proposes to follow, and the amount and character of equipment he/she proposes to use, which shall be subject to the approval of the District. The approval of the District shall not be considered as relieving the Contractor of the responsibility for the safety of his/her method or equipment or from carrying out the work in full accordance with the plans and specifications.

3.03 ABANDONMENT OF PIPELINES

Abandon and close pipe by a water tight plug of concrete not less than three (3) feet thick at each pipe end and lateral crossing.

3.04 ABANDONMENT OF MANHOLES

Where existing manholes are to be abandoned, all pipes entering the manholes shall be securely plugged with a three (3) foot concrete plug. The manhole shall be demolished to an elevation three (3) feet below finished grade and backfilled with intermediate backfill compacted to the requirements of the typical trench section shown on the plans. The surface shall be restored as shown on the typical trench section shown on the plans.

Where manholes to be abandoned are in landscaped areas, an approved top soil mix shall be placed in the top 12" and the landscaping shall be restored.

The manhole frame and cover from existing manholes to be removed or abandoned shall not be re-used.

3.05 DISPOSAL OF MATERIALS AND DEBRIS

All materials and debris resulting from the demolition work shall become the sole property of the Contractor and shall be disposed of at a legal disposal site.

3.06 GROUTING (**NOT IN PROJECT**)

END OF SECTION

SECTION 02200

EXCAVATION AND BACKFILL

PART 1 - GENERAL

1.01 DESCRIPTION

A. SCOPE OF WORK

The Contractor shall perform all operations necessary to excavate whatever substance encountered, including earth, sand, gravel, rock, buried structures, pipes or debris, to the depth shown on the plans and required for the installation, to remove unsuitable material and replace with suitable material for bedding and backfill, and to restore the ground surface or pavement to conditions satisfactory to the Engineer.

B. RELATED WORK SPECIFIED IN OTHER TECHNICAL SECTIONS

1. Section 02500: Surface Restoration
2. Section 02602: Trenchless Pipe Replacement
3. Section 02605: Manholes

1.02 DEFINITIONS

A. PIPE BEDDING

Pipe bedding shall be composed of that portion of the backfill material placed in the bottom of the trench for the pipe barrel to rest on.

B. PIPE ZONE BACKFILL

Pipe zone backfill shall comprise that portion of the backfill surrounding the installed pipe, extending after compaction from the foundation to a level twelve (12) inches above the top of the pipe.

C. INTERMEDIATE BACKFILL

Intermediate backfill shall comprise the portion of the backfill from twelve (12) inches above the top of the pipe to the surface.

D. SOUND EARTH

Sound earth shall mean most native soils, with the exception of highly organic spongy soils and fat, highly plastic expansive clays.

E. SOUND GRANULAR SOIL

Sand with a maximum particle size of ¼-inch, or gravel with a minimum grain size of ¼-inch, or crushed rock mixed with sand shall comprise sound granular soil.

F. RELATIVE COMPACTION

Relative compaction shall be taken to mean field density values expressed as a percentage of the laboratory standard maximum density, as determined by the methods of ASTM D-1557-91 and D-1556-90 or ASTM D-2292-91 and D-3017-88 (Nuclear Method).

1.03 QUALITY ASSURANCE

The District will retain a Soils Engineer who will conduct compaction tests to determine compliance with soil compaction requirements as described herein above.

1.04 SUBMITTALS

- A. The Contractor shall submit to the Engineer copies of his/her proposed methods of sheeting, shoring and bracing as approved by the Division of Industrial Safety, per these specifications.
- B. The Contractor shall submit to the Engineer samples of all materials proposed for use as pipe bedding and backfill. When requested by the Engineer, the Contractor shall submit a sieve analysis of the materials proposed to be used at no cost to the District.

1.05 BRACING AND SHEATHING

- A. The Contractor shall do and be solely responsible for all bracing, sheathing and shoring necessary to perform and protect all excavations as required for reasons of safety and to conform to governing laws. Where required by the Division of Industrial Safety, shoring shall be designed by a registered Civil Engineer. Excavations shall be supported so that the ground alongside the excavations will not slide, and all existing improvements, either on public or private property, will be fully protected from damage. Additional supports requested by the Engineer shall in no way relieve the Contractor of his/her responsibility for the sufficiency of his/her precautions.
- B. All shoring, bracing and sheathing above the top of the pipe shall be removed from the trench or excavation. Sheathing which has been driven below the invert of the pipe must not be removed. Under wet soil conditions, sheathing shall be left in the trench up to the top of the pipe.
- C. The cost of such bracing, shoring and sheathing shall be included in the price for shoring and no additional allowance will be made therefor.

1.06 CONTROL OF WATER

- A. The Contractor shall remove all water which may accumulate in the excavation during the progress of the work by pumping or other suitable methods so that all work can be done in the dry. Trenches and other excavations shall be kept free of water while the pipe or structures are being installed, while concrete is setting, and until backfill has progressed to a sufficient height to anchor the work against possible flotation or leakage. Water shall be disposed of in such a manner as to cause no injury to public or private property or be a menace to the public health.

- B. Where water is encountered, the trench excavation shall be carried twelve (12) inches below the pipe invert in which case the pipe bedding material shall be 1½-inch crushed rock.
- C. The cost of such removal of water and additional excavation and pipe bedding material shall be included in the unit bid price per lineal foot of pipeline and no additional allowance will be made therefor.

1.07 REMOVAL OF UNSTABLE MATERIAL

- A. Where unstable soil is encountered or where the bearing capacity is unsatisfactory to the Engineer, the soil shall be removed to a depth of twelve (12) inches below the pipe barrel and replaced with 1½-inch crushed rock.
- B. The Contractor shall not be relieved thereby of his/her responsibility otherwise to employ procedures necessary to keep the trench bottom in a workable condition and provide a firm and adequate bedding for the pipe.
- C. The cost of trench stabilization shall be included in the price per lineal foot of pipeline and no additional allowance will be made therefor.

PART 2 - PRODUCTS

2.01 MATERIALS

A. GENERAL

The Contractor shall provide and install all materials as shown on the drawings and/or as specified herein.

B. CRUSHED ROCK

1. Crushed rock shall be hard, sound and durable and shall not slake or disintegrate in water.
2. One and one-half inch (1½") crushed rock shall be uniformly graded with one hundred percent (100%) passing a 1½" sieve and not more than five percent (5%) passing a 3/8" sieve.
3. Three-quarter inch (¾") crushed rock shall be uniformly graded with one hundred percent (100%) passing a ¾" sieve and not more than five percent (5%) passing a ¼" sieve.

C. CLASS 2 AGGREGATE BASE

Class 2 aggregate base shall conform to Section 26, AGGREGATE BASES, of the Standard Specifications, Paragraph 26-1.02B. The grading shall be ¾" maximum.

D. SLURRY CEMENT BACKFILL (ALSO INDICATED ON PLANS AS CDF)

Slurry cement backfill shall be a cement slurry mix consisting of the following per cubic yard:

94 lbs	Cement
250 lbs	Pozzolan
1,618 lbs	C-33 Sand
1,121 lbs	3/8 x No. 8 per Pea Gravel
8 - 12%	Air Entrainment

After placement, the slurry mix shall not be disturbed.

E. TOPSOIL

Topsoil shall be imported, fertile, friable, natural, productive soil containing a normal amount of humus and capable of sustaining healthy plant life. Topsoil shall be free of subsoil, heavy of stiff clay, rocks, gravel, brush, roots, weeds, noxious seeds, sticks, trash and other deleterious substances. Soil shall not be infested with nematodes or with other noxious animal life or toxic substances. Soil shall be obtained from well-drained, arable land and shall be of an even texture. Soil shall not be taken from areas on which are growing any noxious weeds, such as Morning Glory, Sorrel, or Bermuda Grass.

F. WATER

Water used for dust control and moisture conditions for compaction shall be reasonably free of objectionable quantities of silt, oil, organic matter, alkali, salts and other impurities as determined by the Engineer. Bay water or water from drainage ditches on the project site shall not be used. Treated and disinfected effluent from the District treatment plant may be used for these purposes providing all water trucks or pipelines are clearly marked with signs stating, "WASTEWATER - DO NOT DRINK." All use of reclaimed wastewater must conform to Health Department Requirements.

PART 3 - EXECUTION

3.01 EXCAVATION

- A. The excavation shall be made to enable the pipe to be laid to the grades and alignment shown on the plans. Excavated materials not required for fill or backfill shall be removed from the site of the work.
- B. Trenches shall be excavated either by hand or by machine beginning at the outlet structure and proceeding upgrade, except as may otherwise be permitted by the Engineer. Hand excavation, tunneling, jacking or boring will be required when use of a machine will cause unnecessary destruction of trees, shrubs, lawns and existing structures above or below ground.
- C. The narrowest practicable trench width which will allow proper densification of pipe zone backfill materials shall be maintained with vertical sidewalls from the foundation to at least the top of the pipe. Trench width at the top of the pipe shall not exceed the maximum trench width shown in the County Specifications. Where general conditions make this impractical, means must be provided, with the approval of the Engineer, for adequately supporting the increased load on the pipe which such widening will cause.
- D. Where sheathing is required, the width of trench shall be increased sufficiently to accommodate the sheathing and timbers.

- E. Excavation for manholes and other structures shall have twelve (12) inch minimum and twenty four (24) inch maximum clearance on all sides. Bell holes shall be excavated accurately to size by hand.
- F. Excavation shall not be carried below the required level. Excess excavation below the required level shall be backfilled at the Contractor's expense with gravel, crushed rock or concrete, as directed by the Engineer, and thoroughly tamped.
- G. In rock, excavation shall be carried six (6) inches below the bottom of the pipe and replaced with an approved material thoroughly tamped to provide a uniform support for the pipe. Permits for blasting shall be secured by the Contractor from the proper authorities. The cost of drilling and blasting shall be included in the unit bid price for lineal foot of pipeline and no additional allowance will be made therefor.
- H. The bottom of all trenches shall be excavated accurately to the required grade with a firm bed to fit the barrel of the pipe. Minor adjustments in elevation required to produce the required invert slope shall be made by adequately bedding the pipe with sound granular pipe bedding materials, as hereinbefore defined, thoroughly compacted along the length of the pipe, underneath, and on both sides. It is essential that a uniform solid bearing be provided under the entire section of pipe.
- I. For flexible pipe (PVC and polyethylene pipe), the pipe bedding (bottom of trench) shall be firm, but not hard, and shall consist of pipe zone backfill, free from stones or lumps exceeding one (1) inch in greatest dimension which might bear against the pipe. Suitable foundations shall be prepared by providing a one (1) inch minimum leveling course with loose bedding material graded uniformly in one plane for the full length of the pipe. Foundations shall provide uniform support under the haunches of the pipe up to the spring line along the full length of each pipe section.

3.02 BACKFILL

A. GENERAL

1. After the pipelines and their appurtenances have been properly constructed and inspected and after joints, plaster and concrete have set sufficiently to prevent damage, backfilling shall be done with approved material free from large clods or stones.
2. The Contractor's attention is called to the fact that it will be his/her responsibility to obtain an encroachment permit for all work to be done in streets, roads, highways or railroad rights-of-way from the proper agency having jurisdiction and that the method of backfilling of trenches must conform to the requirements of such agency. Where imported materials will be required, the cost of furnishing and placing such materials shall be included in his/her bid price for sewer construction and no additional allowance will be made therefor.

B. PIPE ZONE BACKFILL

1. Backfill materials shall be so placed that the pipe will not be displaced, excessively deflected, or damaged. Materials placed as pipe zone backfill shall be free of stones or lumps exceeding one (1) inch in greatest dimension and shall be so placed as to prevent the formation of voids.

2. Pipe zone backfill preparation shall be placed and compacted determined on the basis of local native soil conditions and such that vertical ring deflection of flexible pipe will be limited to five percent (5%) of the nominal pipe diameter.
3. In general, pipe zone backfill shall be placed immediately after laying the pipe, provided the pipe is true to line and grade.

C. INTERMEDIATE BACKFILL

1. The backfill shall be blended sufficiently to secure the best practicable degree of compaction and stability.
2. Compaction may be performed by mechanical or hand tamping methods or by hydraulic methods as is necessary to achieve the required relative compaction.
3. Care shall be taken during compaction to prevent displacement of the pipe due to floating or shifting and to prevent hydrostatic or impact damage to the pipe and foundation. Heavy mechanical tamping or rolling equipment directly over the top of the pipe, such as might result in excessive reduction of the vertical diameter of the installed pipe, shall be avoided.
4. Intermediate backfill above the pipe zone backfill shall not be placed until conformance with specified relative compaction of pipe zone backfill material has been confirmed.

3.03 MINIMUM COVER

Where the pipe has less than thirty (30) inches cover within a street right-of-way or other areas subject to traffic, an eight (8) inch concrete slab cover shall be poured over the back-filled trench. Such slab shall be as detailed on the plans or as a minimum shall be reinforced with Number 5 bars at twelve (12) inches c.c. each way and shall be at least twelve (12) inches wider than the trench. The concrete slab mix shall contain not less than six (6) sacks per yard and a water cement ratio of five (5) gallons per sack.

3.04 PRECAUTION AGAINST FLOTATION

The Contractor shall take every precaution against the flotation of the pipe due to water entering the trench or while pouring concrete encasement. In case of flotation, the Contractor shall replace the pipeline or portions thereof at his/her own expense and make good any injury or damage that may have resulted.

3.05 BACKFILL DEFECTS

Within one (1) year after acceptance of the project, the Contractor shall promptly refill and repair all trenches which settle or otherwise show defects. All shrubs, trees, lawns, patios, structures and other property disturbed during the course of the work shall be restored to their original condition to the satisfaction of the Engineer.

3.06 PAYMENT

The cost of excavation, backfilling, watering, compacting and imported material, if necessary shall be included in the bid price for the construction work and no additional allowance will be made therefor.

SECTION 02500

SURFACE RESTORATION

PART 1 - GENERAL

1.01 DESCRIPTION

A. SCOPE OF WORK

Work included in this section shall consist of furnishing all labor, material, equipment, tools and services required for the performance of paving and surfacing operations, including repair of curbs, gutters, sidewalks, etc., as specified herein and/or as shown on the Drawings, or as necessary to complete the project. Any concrete curbs, gutters or sidewalks damaged by the work shall be repaired or replaced in kind.

B. RELATED WORK SPECIFIED IN OTHER TECHNICAL SECTIONS

1. Section 02200: Excavation and Backfill
2. Section 02602: Trenchless Pipe Replacement

1.02 SUBMITTALS

The Contractor shall submit to the Engineer data describing the proposed surface restoration materials.

1.03 PAYMENT

- A. Unless specifically itemized as a bid item, payment for restoration of all surfaces and surface improvements damaged as a part of the work, including asphalt pavement, paths, sidewalks, curbs, gutters, landscaping, etc., shall be included in the bid price for the construction of the pipeline and structures and no additional allowance will be made therefor.
- B. The Contractor shall be responsible for any off-site improvements which are damaged as a result of the Contractor's operation or by the travel of trucks on roads to and from the work area. Any such off-site damage shall be replaced at the Contractor's expense.

PART 2 - PRODUCTS

2.01 GENERAL

- A. Materials for paving and surfacing shall conform to the applicable provisions of the State Standard Specifications and the County Specifications.
- B. Pavement restoration for public roads shall conform to the requirements of the agency having jurisdiction over the roadway right-of-way.

2.02 PAVING AND SURFACING MATERIALS

A. AGGREGATE BASE

Aggregate base shall be Class 2, conforming to Section 26 of the State Standard Specifications. Minimum relative compaction shall be 95%. If pavement having a structural section greater than 15" is cut, additional base material may be required by the Engineer. Base shall be placed and compacted prior to placing of temporary paving.

B. ASPHALT CONCRETE

1. Asphalt concrete shall conform to the applicable requirements of Section 39 of the State Standard Specifications for Type B aggregate. Paragraph 39-8 is not applicable. Surface courses shall be constructed using 1/2-inch maximum graded aggregate. Lower courses shall be constructed using 3/4-inch maximum graded aggregate.
2. Paving asphalt shall be PG-64-10 or 64-16, conforming to the requirements of Section 92 of the State Standard Specifications. Six (6) percent bituminous binder shall be provided.

C. CONCRETE

Concrete for replacement of curbs, gutters, sidewalks, valley gutters, etc. shall be minimum six (6) sack mix, four thousand (4,000) psi compressive strength.

PART 3 - EXECUTION

3.01 PLACEMENT OF ASPHALT CONCRETE

A. DELIVERY AND SPREADING

Bituminous mixtures shall be delivered to the roadbed at temperatures specified in Section 39 of the State Standard Specifications. Spreading of the mixture shall be in accordance with Section 39 of the State Standard Specifications. All loads shall be covered with tarpaulin or other material during transportation.

B. COMPACTION

Initial or breakdown rolling and the final rolling of the uppermost layer of the asphalt concrete shall be compacted in accordance with Section 39 of the State Standard Specifications. Compaction by vehicular traffic shall not be permitted.

C. PAVEMENT THICKNESS

Pavement shall match the existing adjoining pavement in thickness, or as indicated on the Drawings, or as specified, whichever is greater.

D. JOINING PAVEMENT

The joints between old and new pavements or between successive days' work shall be carefully made in such manner as to insure a continuous bond between old and new sections of the course. Edges of existing pavement shall be exposed and cleaned and edges cut to straight, vertical surfaces. All joints shall be painted with a uniform coat of tack coat before the fresh mixture is placed.

E. PAVEMENT CUTTING

Trenches and other excavations in asphalt paved areas shall be cut by means of a saw cut or spade tool to the full depth of the pavement. Pavement cuts shall be laid out by a chalk line and care shall be taken to ensure neat, straight edges.

After the Engineer has approved a section of trench for final paving, the Contractor shall strip out all temporary pavement to the full depth of the new pavement section as specified. Spalled or cracked sections of pavement beyond the excavation limits which, in the opinion of the Engineer, show signs of having separated from the adjoining pavement or are moveable, shall be removed and replaced with new pavement. Broken edges of pavement shall be trimmed along lines parallel to the trench edges. Exposed subgrade materials shall be compacted to the same standards as the adjoining trench backfill.

F. CONFORMANCE TO EXISTING IMPROVEMENTS

Asphalt concrete overlays shall be tapered to conform to existing paving, gutters, catch basins, etc. as directed by the Engineer.

G. PLACEMENT OF THERMOPLASTIC TRAFFIC STRIPES AND PAVEMENT MARKERS

Restore all thermoplastic traffic striping and pavement markers to match existing which was damaged as part of the project.

3.02 RESTORING OTHER AREAS

- A. Other surfaced areas other than pavement shall be restored by replacement of identical surface and base when practicable. In no case shall the thickness and method of placement of curbs, sidewalks, driveway approaches, valley gutters, etc., be less than that specified in the County Specifications.

All concrete curbs, gutters, aprons, patios, driveways and sidewalks which are broken, crushed or damaged by the installation of the improvements shall be reconstructed by and at the expense of the Contractor, of the same kind of material and of the same dimensions as the original work, with the minimum requirement that concrete shall be Class B (5-sack), and the minimum thickness for concrete slabs, etc., shall be four (4) inches. The repairs shall be made by removing or replacing the entire portions between joints by removing the damage portions by concrete saw and not by merely refinishing the damaged part. All work shall match the appearance of the existing improvements as nearly as practicable.

- B. All trenches in landscaped or cultivated areas shall have the top twelve (12) inches backfilled with topsoil. After installation, the topsoil and any adjacent unimproved land which has been compacted by the operation of the Contractor shall be thoroughly scarified and the surface cleaned of all large clods, stones or debris.
- C. In lawn areas, the Contractor shall replace any grass removed for excavations, or which is damaged by his operations, with sod. Ground cover materials other than lawn shall be replaced in kind to the satisfaction of the Engineer.
- D. All landscape irrigation piping and control wires which are damaged by the work shall be replaced in kind.
- E. The Contractor shall maintain all restored lawn and landscaped areas for a minimum of thirty (30) days after acceptance of the project by the District.

END OF SECTION

SECTION 02602

TRENCHLESS PIPE REPLACEMENT

PART 1 - GENERAL

1.01 DESCRIPTION

A. SCOPE OF WORK

Work included in this section shall consist of furnishing all materials, labor, equipment, tools, and services required for the fabrication, construction, and trenchless replacement of pipelines and appurtenances as specified herein, and/or as shown on the drawings, or as necessary to complete the project. Trenchless pipe replacement is defined as pipebursting, directional drilling and pilot tube boring.

B. RELATED WORK SPECIFIED IN OTHER TECHNICAL SECTIONS

1. Section 02200: Excavation and Backfill
2. Section 02500: Surface Restoration
3. Section 02605: Manholes
4. Section 02659: Cleaning and Video Inspection

1.02 SUBMITTALS

Prior to construction, the Contractor shall submit information to the Engineer showing details of the trenchless pipe replacement method he proposes to use, together with information of the pipe materials and lateral connections and the design of special fittings and bends, closures, and deflection of pipe joints as required to conform to the plan and profile of the pipeline.

1.03 PAYMENT

The cost of all trenchless pipe replacement, including all lateral connections and testing, shall be included in the bid price per linear foot of pipeline and no additional allowance will be made therefor.

PART 2 - PRODUCTS

2.01 GENERAL

- A. All materials shall be new, shall conform to these specifications and to the sizes and details shown on the plans. All materials shall be subject to test by the Contractor at the point of manufacture or at the site of the work. All materials which may fail to meet the requirements of the specifications herein referred to shall be rejected and shall be removed from the site of the work.
- B. Pipe diameters shown on the plans are nominal pipe sizes.

2.02 PIPELINE MATERIALS

A. GENERAL

Pipeline materials allowable for each pipeline are shown on the plans. The pipe and materials specified in this Section include all the types of pipe materials which could be used for one or more items in the project.

B. POLYETHYLENE PIPE AND FITTINGS (HDPE PIPE)

1. GENERAL. Where polyethylene pipe and fittings are shown on the Plans and/or specified, the Contractor shall furnish and install polyethylene pipe manufactured to conform to the following specifications.
2. TYPE AND MANUFACTURE. Polyethylene pipe and fittings shall be Type III Category 5, Grade P34, per ASTM D-1248 (PPI designation P 4710), with a DR=17, having the following properties:

<u>Property</u>	<u>Value</u>	<u>ASTM Test</u>
Density, min.	0.955-0.957 gms/cc	D-1505
Melt Flow - Condition E	0.20 gms/10 min	D-1238
or Condition F	1.5 gms/10 min	D-1238
Environmental Stress Cracking Resistance w/no failures or stress crack initiation (Condition C)	1,000 hrs	D-1693
Tensile Strength, Yield 2 in/min	3,100 psi	D-638
Brittleness Temperature	180° F	D-746
Long-Term Strength @ 73°F	1,600 psi	D-2837
@ 140°F	800 psi	D-2837
Cell Classification	355434C or 335434C	D-3350

Polyethylene pipe shall be Driscopipe 1000, Dupont, or equal. The pipe interior shall be grey.

3. The polyethylene resin shall contain 2% carbon black antioxidant, well dispersed, and be stabilized against ultraviolet degradation to provide protection during processing and subsequent weather exposure.
4. Pipe shall be made to diameter and tolerances as shown in manufacturer's literature.
5. All pipe shall be made from virgin material. All resin in all the pipe and fittings must be produced by a single resin manufacturer and shall be fully traceable. No rework compound, except that obtained from the manufacturer's own production of the same formulation, shall be used.
All pipe fittings and specials shall be furnished by the same pipe manufacturer.
6. Pipe shall be homogeneous throughout and be free of visible cracks, holes, foreign material, blisters, or other deleterious faults.

7. The Contractor shall furnish and install the proper connecting pieces and/or transition sleeves in every case where it is necessary to join pipes of different diameters, materials, or types of joint.
8. Fusion joining and other procedures necessary for correct assembly of the polyethylene pipe and fittings will be done only by personnel trained in those skills to the satisfaction of the Engineer and the pipe supplier.
9. Only those tools designed for joining procedures and approved by the pipe supplier and Engineer shall be used for assembly of pipe and fittings to insure proper installation.
10. Where shown on the plans, polyethylene pipe shall be connected to systems or fitting of other materials by means of an assembly consisting of a polyethylene flange adapter butt-fused to the pipe, a backup ring of stainless steel made to ASA B-16 dimensional standards (with modified pressure rating, bolts of stainless steel and compound gasket).
11. The supplier shall provide polyethylene pipe with a permanently imprinted manufacturer's brand name, pipe size, and other identification for tracing pipe quality to raw material source. The HDPE pipe shall also be identified with green stripes and shall have a white or light gray interior.
12. The pipe supplier shall furnish the system components, fusion machine of type specified and pipe support stands. The Contractor shall supply the power source for operation of the fusion machine.
13. The Contractor shall cut out and replace defective joints at no additional cost to the District. Any section of the pipe with a gash, blister, abrasion, nick, scar, or other deleterious fault greater in depth than ten percent (10%) of the wall thickness (ASTM 585), shall not be used and must be removed from the site. However, a defective area of the pipe may be cut out and the joint fused in accordance with the procedures stated above. In addition, any section of the pipe having other defects such as concentrated ridges, discoloration, excessive spot roughness, pitting, variable wall thickness or any other defect of manufacturing or handling as determined by the District shall be discarded and not used.
14. Terminal sections of pipe that are joined within the insertion pit shall be connected with a mechanical coupling (e.g., Central Plastic or equivalent) or a non-shear restraint coupling. All connections shall be in conformance with the manufacturer's installation procedures.

PART 3 - EXECUTION

3.01 GENERAL

- A. Where shown on the plans, the Contractor shall rehabilitate sanitary sewers by a trenchless pipe replacement method as specified herein.
- B. The trenchless pipe replacement process shall utilize High Density Polyethylene Pipe as the carrier pipe.

- C. Contractor shall be experienced in this type of work having done three projects of 10,000 LF or more in past three years.

3.02 SEWER CLEANING

Sewers shall be cleaned prior to locating the laterals. Cleaning shall consist of the use of a hydro-flusher, rodder, root cutters including use of hand rodding equipment in easement areas where necessary as well as any other cleaning equipment necessary to remove foreign materials including adhered grease and dirt from the pipe walls together with all roots, rocks and debris from the sewer, manhole inverts and structures to obtain a clear picture of the internal condition of the line. Use of chemicals or herbicides is not permitted.

3.03 LOCATION AND POTHOLING OF SEWER LATERALS

- A. Where shown on the plans, the Contractor shall locate all existing live sewer laterals which connect to the pipe to be rehabilitated. Laterals shall be located either by television inspection, inserting a "ferret" locating device, dye testing while televising or by potholing with verification that the lateral is live.
- B. Once the lateral is located it shall be potholed at the point of connection with the building lateral and/or sewer main.
- C. The cost of locating the laterals shall be paid for in accordance with the unit bid price in the proposal, and no additional allowance will be made therefor.

3.04 PIPEBURSTING

- A. When shown on the plans sewer mains shall be pipeburst using a method that will not cause undue vibration or impact in the ground around the pipe or damage adjacent utilities. Use pneumatic pipebursting equipment with pneumatic bursting head will be allowed.
- B. The size-for size or upsizing installation of new pipe shall be accomplished by the following procedures:
 1. The polyethylene pipe shall be attached to the rear of the pipe bursting machine with the hose lines and cables passing through the annulus of the replacement pipe.
 2. A cable or chain shall be inserted from the launching trench through the existing pipe to the reception manhole where it shall be attached to the winch and the pipe bursting head.
 3. The pipe bursting system with the replacement polyethylene pipe attached shall be lowered into the launching trench while the directional winch chain is simultaneously being tensioned, locating the pipe bursting head in the existing sewer line.
 4. The pipe bursting action shall be initiated following the continuously tension winch chain toward the receiving manhole.
 5. When the system reaches the reception manhole or the point of connection to an existing pipeline the polyethylene pipe shall be disconnected from the rear of the machine and the unit prepared for the next run.

C. All rehabilitated sewer mains shall be tested, cleaned and TV-inspected as specified herein..

3.05 LATERAL RECONNECTIONS

The Contractor, after a suitable relaxation period shall reconnect all service connections. The installed pipe shall be allowed the manufacturer's recommended amount of time, but not less than four (4) hours, for cooling and relaxation due to tensile stressing prior to any reconnection of service lines.

Lateral connections to HDPE pipe shall be made by electrofusion HDPE saddles, Central, Friatec or approved equal.

The connection between the existing lateral and new polyethylene lateral shall be by a banded rubber coupling with stainless steel shear bands, Fernco, Caulder, or equal.

New HDPE laterals shall be reconnected to the new pipe by means of an electrofusion saddle. The polyethylene pipe shall be drilled out to the same diameter as the saddle and deburred.

3.06 MANHOLE CONNECTIONS

All pipeline connections to manholes shall be made by encasing a rubber adapter coupling which is installed around the pipe in the poured concrete manhole base to make a watertight connection.

After the polyethylene pipe has been inserted in the existing manhole, the Contractor shall trim the polyethylene pie and anchor the pipe to the manhole base. Care must be exercised to prevent the new pipe from slipping out of position prior to final sealing of the manhole. The polyethylene replacement pipe shall protrude far enough into the manhole to allow the sealing and trimming operations to be performed.

A minimum of twelve hours after pipe insertion, a rubber seal shall be placed in the annular space between the polyethylene pipe outside diameter and the inside diameter of the existing hole in the manhole at each manhole location, together with caulking and non shrink grout to form a water-tight seal.

3.07 TESTING OF COMPLETED SEWER MAINS

A. GENERAL

1. Gravity sewer lines, laterals and appurtenances shall be substantially watertight. All precautions shall be taken by the Contractor to secure watertightness throughout the component parts of the system. All jointing of pipe shall be subject to rigorous inspection by the Engineer or his representative. In addition, before the acceptance of the work and prior to the admission of any sewage into the system, the Contractor shall perform the tests herein specified and otherwise demonstrate to the satisfaction of the Engineer the watertightness of the sewer lines, including laterals and manholes and appurtenances. All leakage in excess of the maximum allowable amount hereinafter stipulated shall be corrected.

2. Testing shall be performed after backfilling and after manholes are finished. The Contractor shall make whatever preliminary tests he deems necessary prior to backfilling to satisfy himself that the completed and backfilled line will meet the hydrostatic tests herein required.
3. The test shall be conducted to include the new sewer mains and all new house connecting sewers and laterals. The test shall meet the requirements as herein specified. Any visible infiltration into sewers or manholes, no matter how slight, shall be repaired.
4. The Contractor shall furnish all facilities, including labor, materials, pumps, equipment, and tools necessary to conduct the tests and cleaning operations, and he shall repair all leaks. The cost of testing and cleaning sewers shall be included in the unit bid price per lineal foot of sewer, and no additional allowance will be made therefor.

B. ISOLATION FROM EXISTING SYSTEM

The Contractor shall flush all sewer lines after backfilling and prior to testing. Accumulated material shall be removed at each manhole, and no material shall be allowed to enter the existing sewer system.

C. SIDE SEWER TESTING

All newly rehabilitated side sewers (laterals) shall be plugged at the cleanout and tested together with the sewer main.

D. AIR TESTING

Air testing of the sewer pipe will be permitted. The air test pressure shall be four (4) psi at the beginning of the test. For all pipe diameters there shall be no pressure drop over a ten (10) minute test period. Any leaks discovered shall be repaired by the Contractor at his expense.

3.08 PRECAUTION AGAINST FLOTATION

- A. The Contractor shall take every precaution against the flotation of the pipe due to water entering the trench. In case of flotation, the Contractor shall replace the pipeline or portions thereof at his own expense and make good any injury or damage that may have resulted.
- B. Care shall be taken in backfilling the pipe so as not to disturb the material supporting the pipe or otherwise cause displacement of the pipeline.

3.09 PRESERVATION AND CLEANING UP

- A. The Contractor shall properly preserve and clean the work as it progresses. At regular intervals, or as directed, rubbish and debris shall be collected and removed by the Contractor.
- B. Upon the completion of the work, the Contractor shall clean up the whole work, and all false-work, equipment, tools, rubbish, and other temporary material shall be removed from the site, which shall be left in a clean condition acceptable to the Engineer.

SECTION 02605

MANHOLES

PART 1 - GENERAL

1.01 DESCRIPTION

A. SCOPE OF WORK

Work included in this section shall consist of furnishing all materials, labor, equipment, tools, and services required for the fabrication, construction, and laying of pipelines and appurtenances as specified herein, and/or as shown on the drawings, or as necessary to complete the project.

B. RELATED WORK SPECIFIED IN OTHER TECHNICAL SECTIONS

1. Section 02200: Excavation and Backfill
2. Section 02500: Surface Restoration
3. Section 02602: Trenchless Pipe Replacement

1.02 SUBMITTALS

Prior to manufacture, the Contractor shall furnish drawings for the information to the Engineer showing details of fabrication of the manholes proposed to be used.

1.03 QUALITY CONTROL

All manhole and casting materials shall be inspected and approved prior to installation. The acceptance of any material or finished members by the Inspector shall not be a bar to their subsequent rejection, if found defective. Rejected material shall be immediately removed from the site and replaced promptly by the Contractor.

1.04 PAYMENT

The cost of all manhole construction including all excavation, manhole base, forming of channels, cast iron frame and cover, rebar, backfilling, compaction and steel plates, temporary resurfacing shall be paid for per manhole in accordance with bid item therefor and no additional allowance will be made therefor.

PART 2 - PRODUCTS

2.01 CONCRETE MANHOLES

All manhole sections shall conform to ASTM C-478, except that Type II modified Portland cement shall be used. The design, the specifications and the name of the manufacturer of any manhole units shall be submitted to the District for approval prior to purchase.

2.02 CASTINGS

Castings shall conform to the requirements of ASTM A-48, Class 30.

Castings shall conform to the shape and dimensions shown on the Standard Drawings. All castings shall be clean and free from blow or sand holes or defects of any kind.

The cover and its seat in the frame shall be machined so that the cover will sit evenly and firmly in the frame.

Cast iron frames and covers shall be dipped or painted with asphalt which will form a tough, tenacious, non-scaling coating which does not have a tendency to become brittle when cold or sticky when hot. Covers shall be easily removable.

2.03 SHALLOW MANHOLES AND HDPE MANHOLES (HDPE MANHOLES NOT USED)

The shallow manholes and HDPE manholes shown on the plans shall be constructed per the Details for these manholes as shown on the plans.

PART 3 - EXECUTION

3.01 MANHOLE CONSTRUCTION

An approved form ring conforming to the dimensions of the barrel section joint shall be used to form a joint groove in the manhole base prior to setting the first barrel section. The concrete base shall be sufficiently cured to the satisfaction of the District before the first barrel section is set. All joint surfaces of sections and the manhole base shall be thoroughly cleaned prior to setting precast sections. These various sections shall be set in a Ram-Nek sealing gasket, or equal, and installed in accordance with the manufacturer's recommendations.

Handling of barrel sections after the sealing gasket has been affixed shall be carefully controlled to avoid bumping the gasket and thus displacing it or covering it with dirt or other foreign materials. Any gaskets so disturbed shall be removed and replaced if damaged and repositioned if displaced. Care shall be taken to properly align the manhole section with the previously set section before it is lowered into position.

Use of precast manhole bases will not be permitted. Poured in place concrete manhole bases must be used.

3.02 MANHOLE CHANNELS

Pipe shall be used as a form for the channel if the proper positions of the flexible joints can be maintained. Whether pipe or channel forms are used, after the manhole base concrete has taken a set, the channel shall be checked with the proper template. All channels shall be finished smooth with a steel trowel.

3.03 ADJUSTING OR REPAIRING MANHOLES

All workmanship and materials shall conform to these Specifications and to the details shown on the Plans. In the case of existing brick or cast-in-place concrete manholes, repair or adjustment in kind or with grade ring, may be permitted upon approval of the District. Standard undamaged frames and covers shall be reinstalled unless otherwise directed by the District. Where the completed manhole throat will exceed twelve (12) inches, adjustment shall be made by removing the upper portion of the manhole down to the first barrel section. Concrete barrel and cone sections shall be used to reconstruct the upper portion of the manhole in accordance with the Standard Drawings.

Before any work is started on adjusting or repairing a manhole, the channel inside the manhole base shall be covered with a temporary debris cover, consisting of plywood and canvas. This temporary debris cover shall be kept in place during all work, and upon completion, the canvas and the plywood shall be carefully removed from the manhole interior allowing no debris to fall or to remain in the manhole.

3.04 TEMPORARY COVERS AND PLUGS FOR MANHOLES

The District must have accessibility to manholes on all live sewers to allow maintenance of the system at all times. In streets, avenues, intersections, lanes, any public thoroughfares involving automobile traffic, buses, trucks, etc., the permanent manhole casting and cover shall be installed on all actively used sewers and sewer mains, including manholes, where live laterals are being used. The permanent manhole, casting and cover shall be brought up to the grade of the temporary asphalt. The manhole, frame and cover shall at a later date be raised to grade when the final permanent paving is done.

Temporary steel plate covers of approved design shall only be used on inactive sewer lines during the construction in subdivisions or other areas not subject to active vehicular traffic where final grades for unfinished roadbeds have not been determined, or where approved or ordered by the District. If the sewer being constructed is actively used, the Contractor shall install the permanent manhole frame and cover so the District can have access to the sewer for maintenance.

A temporary debris cover shall be placed over the base of any existing manhole prior to beginning any adjustment or repair work.

3.05 MANHOLE TESTING

A. GENERAL

All new sanitary sewer manholes shall be watertight. All manholes shall be successfully tested either with clean water or by vacuum testing.

B. WATER TESTING OF MANHOLES

When a manhole is to be water tested the inlet and outlet sewers shall be plugged and the water shall be brought up above the cone section so that the water level is at least three (3) feet above the level of groundwater outside the manhole. Manholes shall be watertight with zero (0) leakage of water as tested over a fifteen (15) minute period.

The Contractor shall repair any and all leaks into the manhole noted during conditions of high groundwater.

C. VACUUM TESTING OF MANHOLES

1. Sanitary sewer manholes may be vacuum tested in lieu of water testing. Vacuum testing of manholes shall be performed twice, first after installation but prior to backfilling and then again after backfilling.
2. Vacuum testing of manholes shall conform to the standard set for in ASTM C1244-93 Standard Test Method for Concrete Sewer Manholes by the Negative Air Pressure (Vacuum) Test.
3. The District representative shall be notified a minimum of two working days prior to the testing of the manholes.
4. The Contractor shall be responsible to perform the tests. The District's representative shall be present during all tests.
5. The Contractor shall document the tests and submit this documentation to the District.
6. Manholes shall be prepared for vacuum testing as follows:
 - a. All lift holes shall be plugged.
 - b. All pipes entering the manhole shall be temporarily plugged, taking care to securely brace the pipes and plugs to prevent them from being drawn into the manhole.
7. Vacuum testing of manholes shall be conducted as follows:
 - a. The test head shall be placed at the top of the manhole in accordance with the manufacturer's recommendations.
 - b. A vacuum of 10 inches of mercury shall be drawn on the manhole, the valve on the vacuum line of the test head closed, and the vacuum pump shut off. The time shall be measured for the vacuum to drop to 9 inches of mercury.
 - c. The manhole shall pass if the time for the vacuum readings to drop from 10 inches of mercury to 9 inches of mercury meets or exceeds the values indicted in Table 1.
 - d. If the manhole fails the initial test the leaks shall be located and the necessary repairs made by an approved method. The manhole shall then be retested until a satisfactory test is obtained.

TABLE 1 - VACUUM TEST TIMETABLE			
<u>MANHOLE DEPTH-FEET</u>	<u>MANHOLE DIAMETER-INCHES</u>		
	48"	60"	72 "
4'	10 sec.	13 sec.	16 sec.
8'	20 sec.	26 sec.	32 sec.
12'	30 sec.	39 sec.	48 sec.
16'	40 sec.	52 sec.	64 sec.
20'	50 sec.	65 sec.	80 sec.
24'	60 sec.	78 sec.	96 sec.
*	5.0 sec.	6.5 sec.	8.0 sec.

*Add "T" times for each additional 2' depth.
(The values listed above have been extrapolated from ASTM designation C924-85.)

8. If the vacuum test fails, or 10" Hg vacuum cannot be obtained the following procedure shall be followed to locate the leaks.
- Shut off vacuum pump
 - Remove vacuum test plate from manhole
 - Then, using a 2 gallon hand pump sprayer (like a garden sprayer), spray the interior surface of the manhole with a soap and water mixture
 - Begin testing
 - After 30 second, stop vacuum and remove vacuum test plate once again
 - Check the inside of manhole for soapy bubbles, indicating the areas that leak

END OF SECTION

THIS PAGE INTENTIONALLY LEFT BLANK

SECTION 02659

CLEANING AND VIDEO INSPECTION

1.01 DESCRIPTION

A. WORK INCLUDED

The work to be done under this Section consists of furnishing all labor, equipment, materials, plant and supervision necessary to clean and TV inspect the sewer lines designated on the Plans attached hereto and made a part hereof and as specified herein.

Additional required work includes performing the sewer condition assessment, data input to a Pipeline Assessment Certification Program (PACP) database and capturing and storing digital images for each event, i.e. lateral connections and all defects, which are recorded on a flash drive and written inspection report as the work proceeds.

1.02 RELATED WORK SPECIFIED IN OTHER TECHNICAL SECTIONS

1. Section 02602: Trenchless Pipe Construction
2. Section 02605: Manholes

1.03 DELIVERABLES

A. CLEANING RECORDS

The Contractor shall make a record of each sewer that is cleaned using the street name, address and structure number of the upstream manhole and the location and type of any problem found.

B. TELEVISED INSPECTION RECORDS

The Contractor shall furnish the District with two (2) copies of the following records:

- a. Televised records of each sewer line TV inspected on a flash drive properly labeled as to date and address or location.
- b. Written reports of inspected sewer lines which include rating and classification of each defect found.
- c. PACP database of inspected sewer lines.
- d. Digital images of all lateral connections and all defects.

C. PROJECT STATUS REPORT

The Contractor shall provide a monthly status report describing the level of completion of various tasks of the work. This request will be used to determine payment as the work proceeds.

1.04 QUALITY REQUIREMENTS

A. COMPANY EXPERIENCE

As a minimum the company shall have at least three (3) years experience and the supervisor two (2) years experience in this type of work. The Contractor shall demonstrate that he/she owns or has access to backup equipment so that the work does not have to be suspended in the event of equipment breaking down.

B. QUALIFICATION OF WORKERS

The Contractor shall provide sufficient skilled workers and supervisor, who shall be present at all times during execution of the work described above, who shall be thoroughly familiar with the type of work involved and the materials and techniques specified. As a minimum the company shall have at least three (3) years experience and the supervisor two (2) years experience in this type of work.

C. PACP OPERATOR CERTIFICATION

Prior to initiating CCTV inspection work associated with condition assessment assignments, the Contractor shall present the Owner with copies of PACP certifications of operators that will be performing the work.

D. WORKER ATTIRE AND VEHICLES

All workers on the CCTV crew shall wear a photo identification badge, and lime green or orange safety vests. Vehicles shall be identified with the firm's name.

1.05 SUBMITTALS

The Contractor shall submit six (6) copies of the following for approval.

- a. Schedule of cleaning and televising.
- b. Brand name, model, specifications of television equipment to be used and sample flash drive, to establish picture quality.
- c. Traffic Control Plan.
- d. Formal procedures demonstrating that current regulatory requirements are conformed to regarding safe manhole entry and verification that all employees are trained on manhole entry procedures.

1.06 NOTIFICATION TO RESIDENTS, BUSINESSES, SCHOOLS AND AGENCIES

The Contractor shall provide the following notifications to the residents, businesses, schools and agencies in the work area:

- a. Post Notices of the cleaning and televising on power poles within the work area.

- b. Deliver a second notification to the affected properties in the form of a door knob hanger forty-eight (48) hours prior to the actual work or as required by the District. Affected properties shall be defined as all the properties in the vicinity of the work including the properties through which and/or over which the Contractor must traverse and work.

The wording of the public notifications will be developed by the District in cooperation with the Contractor and furnished to the Contractor. The notices will have a blank line for the Contractor to write in the date work will be done on the specified property being notified. The District will make the appropriate number of copies and forward them to the Contractor. The Contractor shall remove the posted notices immediately after the work is done.

1.07 SEWER CLEANING

A. GENERAL

All sewers shall be cleaned prior to TV inspection. Cleaning shall consist of the use of a hydroflusher, rodder, root cutters including use of hand rodding equipment in easement areas where necessary as well as any other cleaning equipment necessary to remove foreign materials including adhered grease and dirt from the pipe walls together with all roots, rocks and debris from the sewer, manhole inverts and structures to obtain a clear picture of the internal condition of the line. Use of chemicals or herbicides is not permitted.

B. CLEANING PRECAUTIONS

During sewer cleaning operations, satisfactory precautions shall be taken in the use of cleaning equipment. When hydraulically propelled cleaning tools are to be used (which depend upon water pressure to provide their cleaning force), precautions shall be taken to insure that the water pressure created does not damage or cause flooding of public or private property being served by the sewer. The Contractor shall take particular care in cleaning plastic pipe so as not to damage it with the cleaning equipment. No fire hydrant shall be obstructed in case of a fire in the area served by the hydrant. The Contractor shall make his/her own arrangements for a water meter and any other utility service necessary to complete the work.

C. MANHOLE CLEANING

When necessary, all manhole structures, within the alignment of the sewer main to be televised, shall be cleaned using high-velocity jet equipment. The cleaning process shall remove accumulated debris from all interior surfaces without damaging the structural integrity of the manhole.

If a manhole structure exhibits excessive damage during the cleaning operations, such as concrete spalling, exposed reinforcing, etc., cleaning operations shall immediately cease and the condition shall be immediately brought to the attention of the Engineer.

D. MATERIAL REMOVAL

All grease, sludge, dirt, sand, roots, rocks and other solid or semisolid material resulting from the cleaning operation shall be removed at the downstream manhole or pump station of the section being cleaned. Passing material from manhole section to manhole section, which could cause line stoppages, accumulations of sand, rocks and debris in pump stations, or damage to pumping equipment, shall not be permitted.

E. ROOT REMOVAL

All roots shall be mechanically removed wherever root intrusion is significant enough to restrict the passage of the camera and/or obtaining a clear picture. Procedure may include the use of rodding machines. Tree roots found shall be routinely reported on the Televised Inspection Report and peripheral work, as required as part of the Project.

1.08 CONTROL OF SEWAGE FLOW

A. PLUGGING OR BLOCKING

When necessary to plug or block the sewage flow, sewer line plug shall be inserted into the line upstream of the section being worked. The plug shall be so designated that all or any portion of the sewage can be released. During TV inspection, flow shall be reduced to levels that will allow full inspection of the pipe interior. After the work has been completed, flow shall be restored to normal.

The Contractor shall control the flow in the sewer being televised as necessary to allow the flow to be below the lens of the camera being used in order to get a clear picture. The Contractor shall notify the District prior to plugging any sewer line. Bypass pumping shall be provided at all times the line is being plugged. The Contractor at his/her option may perform the work on a sewer which has a high flow during the night when flows are low.

B. BYPASS PUMPING

When bypass pumping is required, the Contractor shall supply the pumps, conduits, and other equipment to divert the flow of sewage around the manhole section in which work is to be performed. The bypass system shall be of sufficient capacity to handle existing flow plus any additional flow that may occur during a rainstorm. The Contractor shall be responsible for furnishing the necessary labor and supervision to set up and operate the bypass pumping system. Engines shall be equipped in a manner to keep noise to a minimum.

C. FLOW CONTROL PRECAUTIONS

When flow in a sewer line is plugged, blocked, or bypassed, sufficient precautions must be taken to protect the sewer lines and connected homes from damage that might result from sewer surcharging. The discharge of any sewage from the sewer system to other than a downstream or adjacent sanitary sewer system is prohibited.

D. REMOVAL OF WATER IN SAGS

When the sewer has a sag where the TV camera goes under water the Contractor shall use jet or other equipment to remove the water in the sag(s) just prior to televising. The beginning, end and depth of the sag and standing water shall be noted on the TV report.

1.09 TELEVISED INSPECTION OF SEWER MAINS

A. GENERAL

After cleaning, the manhole sections shall be inspected by means of closed-circuit color television. The inspection will be done one manhole section at a time under a condition of flow control.

B. EQUIPMENT

Pipe Inspection Camera – Produce a flash drive using a pan-and-tilt, radial viewing, pipe inspection camera that pans ± 275 degrees and rotates 360 degrees. The television camera used for the inspection shall be specifically designed and constructed for such inspection. The camera shall be operative in 100% humidity conditions. Use a camera with an accurate footage counter that displays on the monitor the exact distance of the camera (to the nearest tenth of a foot) from the centerline of the starting manhole. Use a camera with camera height adjustment so that the camera lens is always centered at one-half the inside diameter, or higher, in the pipe being televised. Lighting for the camera shall be suitable to allow a clear picture of the entire periphery of the pipe. A reflector in front of the camera may be required to enhance lighting in dark or large diameter pipe. The camera shall be capable of showing on the digital inspection the Owner's name, Project name, Contractor name, date, line size and material, line identification (Owner's manhole numbers at both ends) and ongoing footage counter. The camera, television monitor, and other components of the system shall be capable of producing picture quality to the satisfaction of the Owner; and if unsatisfactory, equipment shall be removed and replaced with adequate equipment. No payment will be made for an unsatisfactory inspection.

C. TELEVISED RECORDINGS

The purpose of televised recordings shall be to supply a visual and audio record, of problem areas of the lines, that may be replayed. Televised recordings shall include an audio track recorded by the inspection technician during the actual inspection work describing the parameters of the line being inspected (i.e., location, depth, diameter, pipe material), as well as describing connections, defects and unusual conditions observed during the inspection. Televised recording playback shall be at the same speed that is was recorded. Slow motion or stop-motion playback features may be supplied at the option of the Contractor. Once inspected, the flash drive shall be labeled and become the property of the Owner. The Contractor shall have all necessary playback equipment readily accessible for review by the Owner during the project.

D. TELEVISED INSPECTION REPORTS

Each flash drive must be accompanied by a written inspection report approved by the Engineer. This report shall identify televised inspection date, time, project number, company, operator, tape number, location, notes, upstream manhole number, downstream manhole number, pipe type, pipe diameter, flow and camera direction and any other information required by the Engineer. The report shall contain a listing of all pipe events, defects, sags, service connection locations including quadrant location, infiltration points and conditions, etc., observed on a footage basis.

Each pipe event shall include a rating according to the Pipeline Assessment Certification Program (PACP) schedule - defect classification table for the following: cracks, breaks, collapsed sections, misaligned joints, broken joints, sags, debris, root intrusion, and infiltration. The severity of the defect should also be reported. The beginning of all sags of 1/4 pipe, 1/2 pipe and underwater as well as where the camera pulls out of sag should be reported. For each service connection, the quadrant position, its condition and type must be recorded. All other information required for analysis such as degree of deterioration and deformed or collapsed pipe should be reported. All pipe event codes and locations entered on the inspection report must correspond to the event codes, pipe footage and counter displayed on the flash drive.

All televising shall be in color.

E. OPERATION

The camera shall be moved through the line in either direction at a moderate rate, allowing complete visibility of the pipe condition at all times. The camera shall be stopped when necessary to permit proper documentation of the sewer's condition. In no case will the camera be pulled at a speed greater than 30 feet per minute. Power winches that do not obstruct the camera view or interfere with proper documentation of the sewer conditions may be used to move the camera through the sewer line. If, during the inspection operation, the camera will not pass through the entire section of sewer due to an obstruction (i.e. offset, break, protruding lateral), the Contractor shall set up his/her equipment so that the inspection can be performed from the opposite manhole, a reverse set-up.

The importance of accurate distance measurements is emphasized. Measurements recorded on the flash drive should start at the beginning of the pipe in the manhole and shall not include the depth of the manhole. Accuracy of the distance meter shall be checked by use of a walking meter, roll-a-tape, or other suitable device. The accuracy shall be to two tenths (0.2) of a foot.

F. LOCATION OF OBSTRUCTIONS

The Contractor shall locate on the ground any obstruction which necessitates a reverse set up as the District can hire a contractor to repair it. The obstruction shall be located on the ground surface by means of a radio wave transmitter and receiver and marked with green paint and/or a stake. Do not paint patios, walls or private property improvements

1.10 TELEVISIONING OF LATERALS

Where required the contractor shall televise laterals after cleaning using a suitable lateral camera. For each lateral televised, a written log shall be prepared together with a color flash drive labeled as to date, and address or location. The written log and flash drive shall use PACP format.

1.11 FINAL ACCEPTANCE

Acceptance of sewer line cleaning and televising shall be made upon delivery, evaluation and approval of the work products required by these specifications and as measured by the footage successfully televised, verified and approved by the Engineer.

1.12 PAYMENT

The cost for all labor, equipment and materials for sewer cleaning and televised inspection shall be included in the respective bid items therefor and no additional compensation will be allowed.

END OF SECTION

THIS PAGE INTENTIONALLY LEFT BLANK

APPENDIX A

EXAMPLE PERMIT CONDITIONS Town of Tiburon

THIS PAGE INTENTIONALLY LEFT BLANK

TOWN OF TIBURON
PUBLIC WORKS PERMIT CONDITIONS – Permit No. _____

Note: The following standard and checked (✓) conditions apply to this permit.

1. **APPENDING LIST OF CONDITIONS:** In the event that these following conditions conflict with the conditional notes and language found in the Permit Application, the following conditions and special conditions will supersede and prevail.
2. **ACCEPTANCE OF THE PROVISIONS:** It is understood and agreed by the Permittee that all conditions have been read, and understood. The Permittee agrees to comply with all conditions.
3. **KEEP PERMIT ON WORK SITE:** This permit, or a complete copy, shall be kept at the site of the work and upon request must be shown to any representative of the Town or any law enforcement officer.
4. **PERMITS FROM OTHER AGENCIES:** Permittee must obtain all other permits required by other public or private agencies or individuals necessary in order to perform the intended work.
5. **INSPECTION NOTIFICATION:** A preconstruction meeting or discussion will occur. The Permittee shall notify the Maintenance Division at (415) 435-7399 a minimum of **two (2)** working days prior to the performance of any work under this permit. Permittee will provide construction schedule, initially and periodically, and contact information. **All work must be inspected prior, during, and after backfill, or re-excitation will be required at Permittee's expense.**
6. **CONSTRUCTION METHODS:** Any work performed without inspection or contrary to discussions with the Town's inspector, the Marin County Public Works Uniform Construction Standards (latest edition), Caltrans Standard Plans (latest edition) or approved plans shall be deemed non-complying and **will not** be accepted by the Town. Attention is called to the following special provisions:
 - (a) **Underground line (e.g. conduits, mains, services) installation will be neat open cut.**
 - (b) **Cement slurry backfill for trenches is required unless proper compaction can be demonstrated as per attached standards or greater.**
 - (c) **A minimum of six (6) inch saw-cut and removal of pavement beyond trench edge lines will be required.**
 - (d) **If trench is within three (3) feet of edge of curb/gutter, saw-cut and removal will continue to the edge of gutter.**
 - (e) **All PCC concrete replacement will be full panel, score line to score line, or as directed by the Inspector.**
 - (f) **Plating of trenches will be allowed for up to five (5) calendar days. Ramping of plates is required.**
 - (g) **All cement slurry backfill and paving will be completed within ten (or _____) calendar days of excavation for each 100-foot section of pipe installation.**
 - (h) **Backfill, required compaction, final AC paving and/or PCC replacement will be conducted within ten (or _____) calendar days of excavation.**
 - (i) **Temporary repairs to existing grades, backfilling, and making the work site safe are required.**
 - (j) **_____ Others:**

- (g) Pedestrian access shall be maintained and provisions for ADA accessibility shall be required. (Any blockage of public right of way must comply with the Public Works policy regarding disabled access; see handout)

13. **EROSION AND SEDIMENT CONTROL MEASURES:** The Permittee is obligated to insure compliance with all applicable stormwater regulations at all times. The BMPs (Best Management Practices) according to the Marin County Stormwater Protection Program (MCSTPP) and Stormwater Best Management Practice Handbook Construction BMP Fact Sheets shall be implemented and maintained to effectively prevent the potentially negative impacts on this project's construction activities on stormwater quality.

Stockpiles of soil, material, and wastes shall be properly contained and covered to minimize sediment transport from the site to streets, drainage facilities or adjacent properties via runoff, vehicle tracking, or wind.

14. **CLEAN UP:** Upon completion of daily work the Permittee shall clean the right-of-way of all rubbish, construction debris, trees, brush, excess materials, temporary structures and equipment.

15. **SAFETY:**

- (a) The Permittee shall be completely responsible for the conditions of the job site, including safety, and shall not be limited to normal working hours. Work and Safety provisions shall conform to all applicable Federal, State, and local laws, ordinances, and codes, and to the rules and regulations established by the California Division of Industrial Safety applicable to the work.
- (b) The services of the Inspector in conducting construction review of the Permittee's performance is not intended to include review of the adequacy of the Permittee's work methods or safety measures, in, on, or near the construction site, and shall not be construed as supervision of the actual construction nor make the Inspector or the Town responsible for providing a safe place for the performance of work by the Permittee, or subcontractors; or for access, visits, use work, travel or occupancy by any person.
- (c) The Permittee shall carefully instruct all personnel working in potentially hazardous work areas as to potential dangers and shall provide such necessary safety equipment and instruction as is necessary to prevent injury to personnel and damage to property.
- (d) Shoring and Trench Safety Plan - Attention is directed to the Civil Code of the State of California, the State Labor Code, and the State of California Division of Industrial Safety.

16. **PROTECTION OF PERSON AND PROPERTY:** The Permittee shall take whatever precautions are necessary to prevent damage to all existing improvements, including above ground and underground utilities. If such improvements or property are damaged by reason of the Permittee's operations, they shall be replaced or restored to a condition equal to or greater than what existed prior, at the Permittee's expense, without delay.

17. **RESPONSIBILITY FOR REPAIR OF FACILITIES:** All public or private facilities and improvements to remain, including but not limited to structures, telephone cables, roadways, curbs, gutters, parking lots, private drives, and storm drains disturbed during construction of the work shall be repaired and/or replaced by the Permittee to match facilities existing prior to construction. In addition, the Permittee shall be responsible for any settlement damage to such facilities or adjoining areas for a period mentioned in Item 11 - "Guarantee" after acceptance of such required facilities. In the event the Permittee refuses or neglects to make good any loss or damage for which he is responsible under this Permit, the Town may itself, or by the employment of others, make good any such loss or damage, and all cost and expense of doing so shall be charged to the Permittee.

18. **CONTRACTOR'S LICENSE NOTICE:** Contractors are required by law to be licensed and regulated by the Contractor's State License Board.

19. **PRIVATE IMPROVEMENTS:** Any private improvements to be installed on Town right-of-way as part of this permit shall be continuously maintained to a safe, clean, and serviceable level, and that the Permittee agrees to remove said improvements at the Permittee's expense in the event that the Town requests such removal at its discretion.

20. **NO PRECEDENT ESTABLISHED:** This permit is granted with the understanding that this action is not to be considered as establishing any precedent on the question of the expediency of permitting any certain kind of encroachment
21. **INDEMNITY:** The Permittee specifically obligates himself and hereby agrees to protect, hold free and harmless, defend and indemnify the Town, the Engineer and his consultants, and each of their officers, employees and agents, from any and all liability, penalties, costs, losses, damages, expenses, causes of action, claims or judgments, including attorney's fees, which arise out of or are in any way connected with the (a) the Town's issuance of this Permit; or (b) the Permittee's, his Contractor's, or his subcontractors' or suppliers' performance of work under this Permit. To the extent legally permissible, this indemnity and hold harmless agreement by the Permittee shall apply to any acts or omissions, whether active or passive, on the part of the Permittee or his agents, employees, representatives, or Subcontractor's agents, employees and representatives, resulting in liability irrespective of whether or not any acts or omissions of the parties to be indemnified hereunder may also have been a contributing factor to the liability. Unless waived, Permittee shall include the Town, the Engineer and his consultants, and each of their officers, employees and agents as additional insureds on their policy and insurance documents shall be submitted to the Town prior to work commencing. Applicant agrees to indemnify, defend and hold harmless the Town of Tiburon, and its employees, agents and officials from any claims, losses or damages that may arise from (a) the Town's issuance of this encroachment permit or any other permit issued to applicant; and (b) Applicant's exercise of this encroachment permit and any other permit granted by the Town. Proof of insurance is required upon request.

22. OTHER:

Permittee(s):

Print name

Initial

Print name

Initial

APPENDIX B

ENCROACHMENT PERMIT CONDITIONS

City of Belvedere

THIS PAGE INTENTIONALLY LEFT BLANK

CITY OF BELVEDERE

ENCROACHMENT PERMIT CONDITIONS

(June 17, 2022)

Road Closures

- Road Closure Permits will be required at all construction locations. Please see link below for Road Closure Permit Applications.
 - Alcatraz Ave requires a Corinthian Island Road Closure Permit
 - Road Closure Permit must be submitted 10 business days in advance of proposed road closure
 - No road closures are allowed on Corinthian Island on Mondays (garbage pickup) and the third Thursday of each month (street cleaning)
 - Beach Road & Golden Gate/Bella Vista Ave require the standard Road Closure Permit
 - Road Closure must be submitted a minimum of three business days in advance

Traffic Control Plan (TCP)

- A Professional Traffic Control Plan (with 3-5 flaggers) is required for all construction locations
 - Please see Road Closure Permit Application for instructions
 - Traffic Control Plan must be provided by a qualified, licensed traffic control company
 - Business License Application (if needed) can be accessed using the link below

Moratorium Streets

- Alcatraz, Golden Gate and Bella Vista are moratorium streets and will be subject to the Slurry Seal fee (\$0.65 per sq. ft.) to cover the cost of a full roadway width slurry seal on the portion of the roadway affected by the excavation activities.*
- The damaged excavated areas can be assessed during and/or after construction.

Emergency Vehicle Access

- Belvedere PD & Tiburon FD approval of Road Closures & TCP is required to ensure emergency vehicular passage.

Construction Management Plan (CMP)

- The project will require a **Construction Management Plan** identifying the following:
 - Estimated project duration
 - Construction schedule of milestones (excavation, grading, off haul duration, pipe install, flatwork/paving; punch list/final inspection)
 - Excavation and disposal methods
 - Equipment to be used
 - Site access locations
 - Storage and staging locations of materials, vehicles and equipment/portable toilet/debris box/waste bins
 - Encroachment Permits will be needed for storage of materials, equipment and vehicles within Belvedere Public Right of Way
 - Truck loading area and temporary traffic control plan
 - Haul route to/from construction site locations

- Best management practices (BMPs) to be implemented to minimize pollutant exposure, protect exposed pollutants, and remove any pollutants that may accidentally enter stormwater runoff. Please see the **MCSTOPPP Minimum Control Measures for Small Construction Projects** for list of effective BMPs.

The Road Closure Permit, Business License, and Encroachment Permit Applications can be accessed using the following link - **<https://www.cityofbelvedere.org/121/Forms>**.

*Sanitary District No. 5 will pay the City of Belvedere slurry seal fee directly.

SUPPEMENTAL CONDITIONS OF APPROVAL

Sanitary District Pipe bursting project

City of Belvedere contact, Public Works Dept:
Robert Zadrik, Director of Public Works

WORKING HOURS & PUBLIC CONSIDERATION

- Monday – Friday (except holidays) 8:00 a.m. – 5:00 p.m
- Post no parking signs at least 72 hours in advance of work.
- Contractor to provide traffic control plan for review by City of Belvedere (if needed) prior to start of construction operation.
- Shall provide notice to San Rafael Avenue and Bayview residents (sample available) five days prior to start of construction.
- Must notify police, fire, garbage, utility agencies if impacts are expected.
- Follow construction Best Management Practices for Storm Water Protection (BMPs).
- Protection of existing utilities (Storm Drain pipes, Water lines?)

WORK IN PUBLIC RIGHT OF WAY

- An Encroachment Permit must be completed by the contractor before start of work.
- Contractor will notify City at least 72 hrs before Road Closures are proposed.
- All trenches shall be saw cut.
- AC cuts shall be made 6-inches wider than the vertical walls of the trench.
- Backfill above bedding material shall be control density fill. Please submit a design for approval by the City Engineer.
- The Thickness of the replacement paving shall match existing pavement thickness and will be applied in 2-inch maximum lifts.
- Repave trench cut with 4" of AC or match existing if it is greater
- Advanced signing in both directions on Belvedere Ave alerting motorists to work
- Replace all AC from saw cut to face of curb

STORAGE AREAS

Contractor shall arrange for storage area for stockpiling materials, if necessary.

TOILET FACILITIES

Contractor shall supply portable toilets for his use during construction.

Sludge Hauling Agreement

Between

Sanitary District No. 5 of Marin County and

Mill Valley Refuse Service

This Sludge Hauling Agreement ("Agreement") is made this _____ day of ~~October~~ ~~October~~, 20~~24~~~~19~~ ("Effective Date"), by and between Mill Valley Refuse Service, ("MVR") and Sanitary District No. 5 of Marin County ("District"). MVR and the District are referred to collectively as the "Parties".

Recitals

1. MVR is the operator of a disposal service.
2. District owns and operates wastewater treatment facilities located in Tiburon, California ("Facilities").
3. Waste Management, Inc., ("WM") is the operator of a landfill disposal site located in Novato, California ("Redwood Landfill"), which is a Class II-2 disposal facility and is properly permitted to accept sewage sludge, grit, and screenings ("Sludge") for disposal.
4. On January 30, 2012, District entered into an Industrial Waste & Disposal Agreement with WM to receive Sludge at Redwood Landfill, a copy of which is attached as Exhibit "A".
5. Lystek International LTD is the operator of a class A biosolids beneficial reuse site located at the Fairfield Suisun Sewer District Property located in Fairfield CA ("Lystek Facility").
6. District may deliver up to 12 containers of bio-solids to Lystek Facility during the calendar year.
7. MVR and District now wish to enter into this Agreement to provide for MVR to continue to haul Sludge from the Facilities to the Redwood Landfill on the terms provided below.

NOW THEREFORE, the Parties agree as follows:

1. Effective Date and Term:

This Agreement shall become effective upon the Effective Date noted above and will terminate five (5) years from the Effective Date ("Term") unless extended by mutual written agreement signed by the Parties. However, this Agreement shall terminate, and all obligations of the District under this Agreement shall cease immediately, in the event that District, in its sole discretion, decides to discontinue disposal of Sludge at Redwood Landfill or Lystek Facility.

2. Unloading and Discharging:

MVR agrees to use its own vehicles to pick up, haul, and unload District's Sludge to the Redwood Landfill or Lystek Facility. Sludge shall not be taken to any other disposal site without the prior written consent of District.

3. 24 Hour Notice:

MVR agrees to pick up Sludge from District within 24 hours of verbal request from District. Verbal request will be made during MVR's regular office hours of 7:00 a.m. to 3:00 p.m., Monday through Friday.

4. Plant Access:

District agrees to provide access to the Sludge between the hours of 7am to 10pm, Monday through Friday, and 8am to 4pm on weekends.

5. Compensation:

In consideration of the disposal of Sludge at Redwood Landfill by MVR, District shall pay MVR a fee of ~~\$4000360.00~~ per box containing approximately ten (10) cubic yards of Sludge for all Sludge disposed of at Redwood Landfill for the duration of this Agreement and ~~\$1100720~~ per box containing approximately ten (10) cubic yards of Sludge for all Sludge disposed of at Lystek Facility beginning July 1, 2025.

A price increase will be effective on July 1, 2026, and subsequently each July 1st during the term of this Agreement and will be calculated using the Consumer Price Index (CPI) as published by the US Bureau of Labor Statistics for the San Francisco area for the prior 12 months. Any price increase under this Section shall be limited to a minimum of 3.0% and a maximum of 6%.

Said fee does not include dump fees, which shall be separately invoiced and reimbursed at cost by the District.

Formatted: Font: 12 pt

Formatted: Normal, Indent: Left: 0"

6. Cooperation:

Although not a party to or bound by any agreement between District and WM or Lystek, MVR agrees to provide reasonable cooperation to District and WM and Lystek such that District may continue to gain the benefits of, and perform its obligations under, any such agreements.

7. General Conduct of NDS:

MVR agrees to carry out all of its obligations under this Agreement in a safe, legal, and reasonable manner, whether at the District's Facilities, on the public roads, at Redwood Landfill, Lystek Facility or elsewhere. This obligation includes, but is not limited to, operation of vehicles and all other NDS equipment in compliance with any and all federal, state, and local laws and regulations and proper training for drivers in the operation of such vehicles and the picking up, hauling, and unloading of Sludge as required under this Agreement.

8. Landfill Hours:

MVR may dispose of Sludge at Redwood Landfill at any time MVR and WM agree is permissible. MVR may dispose of Sludge at Lystek Facility at any time MVR and Lystek agree is permissible.

9. Sludge And Grit Boxes:

District owns the boxes for the collection of Sludge. MVR shall leave at least one box at each of the Facilities at all times to allow for the collection of Sludge. MVR will maintain and repair District's boxes and will invoice District for repairs and maintenance on a time and materials basis. MVR must maintain all boxes so that the boxes do not drain any wastewater liquids to the public highway.

10. Overweight loads:

District agrees to pay for any overweight tickets for loads hauled in accordance with this Agreement.

11. Compensation for Property Damage:

MVR agrees to reimburse District for damage to any District property, including but not limited to the Facilities, that results from carelessness or negligence on the part of MVR drivers or other MVR personnel.

12. Invoices:

Invoices shall be prepared by MVR on a calendar month basis, and shall specify for each load hauled the time, date and type of load (i.e. sludge, grit, and/or screenings).

13. Indemnification:

MVR agrees to indemnify, hold harmless, and defend District, its officers, employees, and agents (collectively, the "Indemnitees") from and against (i) any and all liability, penalty, claim, demand, action, proceeding or suit, of any and every kind and description, whether judicial, quasi-judicial or administrative in nature, (ii) any and all loss or expense including but not limited to, injury to and death of any person, damage to property, and attorney fees and court costs, and (iii) contribution or indemnity demanded by third parties (each, a "Claim", and collectively, the "Claims"), arising out of or occasioned in any way by, directly or indirectly, MVR's performance of, or its failure to perform, its obligations under this Agreement. The foregoing indemnity shall not apply to the extent that a Claim is caused solely by the active negligence or intentional misconduct of the Indemnitees, but shall apply if the Claim is caused by the joint negligence of MVR and an Indemnitee. MVR's duty to defend and indemnify shall survive the expiration or earlier termination of this Agreement.

14. Environmental Indemnification:

MVR shall indemnify, defend and hold harmless the Indemnitees against all claims, of any kind whatsoever paid, incurred or suffered by, or asserted against Indemnitees arising from or attributable to any repair, cleanup or detoxification, or preparation and implementation of any removal, remedial, response, closure or other plan (regardless of whether undertaken due to governmental action) concerning any Hazardous Wastes released, spilled or disposed of by MVR pursuant to this Agreement. The foregoing indemnity is intended to operate as an agreement pursuant to Section 107(e) of the Comprehensive Environmental Response, Compensation and Liability Act, ("CERCLA"), 42 U.S.C. Section 9607(e), and California Health and Safety Code Section 25364, to defend, protect, hold harmless and indemnify Indemnitees from liability and shall survive the expiration or earlier termination of this Agreement. Notwithstanding the foregoing, MVR is not required to indemnify the Indemnitees against claims arising from MVR's delivery of Sludge to Redwood Landfill unless such claims are due to MVR's negligence or willful misconduct.

15. Insurance:

- a. Types and Amounts of Coverage. MVR shall procure from an insurance company or companies admitted to do business in the State of California, and shall maintain in force at all times during the Term, the following types and amounts of insurance:

- i. Workers' Compensation and Employer's Liability. MVR shall maintain workers' compensation insurance covering its employees in statutory amounts and otherwise in compliance with the laws of the State of California. MVR shall maintain employer's liability insurance in an amount not less than one million dollars (\$1,000,000) per accident or disease. MVR shall not be obligated to carry workers compensation insurance if (i) it qualifies under California law and continuously complies with all statutory obligations to self-insure against such risks; (ii) furnishes a certificate of Permission to Self Insure issued by the Department of Industrial Relations; and (iii) furnishes updated certificates of Permission to Self Insure periodically to evidence continuous self insurance.
- ii. Commercial General Liability. MVR shall maintain commercial general liability insurance with a combined single limit of not less than ten million dollars (\$10,000,000) per occurrence covering all claims and all legal liability for personal injury, bodily injury, death, and property damage, including the loss of use thereof, arising out of, or occasioned in any way by, directly or indirectly, MVR's performance of, or its failure to perform, services under this Agreement.

The insurance required by this subsection shall include:

- 1. Premises Operations (including use of owned and non-owned equipment);
- 2. Personal Injury Liability with employment exclusion deleted;
- 3. Broad Form Blanket Contractual with no exclusions for bodily injury, personal injury or property damage (including coverage for the indemnity obligations contained herein)

The commercial general liability insurance shall be written on an "occurrence" basis (rather than a "claims made" basis) in a form at least as broad as the most current version of the Insurance Service Office commercial general liability occurrence policy form (CG0001). If occurrence coverage is not obtainable, MVR must arrange for "tail coverage" on a claims made policy to protect District from claims filed within four (4) years after the expiration or earlier termination of this Agreement relating to incidents that occurred prior to such expiration or termination.

- iii. Automobile Liability. MVR shall maintain automobile liability insurance covering all vehicles used in performing service under this Agreement with a combined single limit of not less than ten million dollars (\$10,000,000) per occurrence for bodily injury and property damage.
- iv. Pollution (Environmental Impairment) Liability. MVR shall maintain pollution liability insurance coverage of not less than ten million dollars (\$10,000,000) per occurrence covering claims for on-site or off-site bodily injury and property damage as a result of pollution conditions arising out of its operations under this Agreement.

16. Relationship of the Parties:

The Parties intend that MVR shall perform the services required by this Agreement as an independent contractor engaged by the District and not as an officer or employee of the District nor as a partner or

joint venturer with the District. No employee or agent of MVR shall be deemed to be an employee or agent of the District. Except as expressly provided herein, MVR shall have the exclusive control over the manner and means of conducting the services performed under this Agreement, and over all persons and entities performing such services. MVR shall be solely responsible for the acts and omissions of its officers, employees, subcontractors, and agents. Neither MVR nor its officers, employees, subcontractors, or agents shall obtain any rights to retirement benefits, workers' compensation benefits, or any other benefits that may accrue to District employees by virtue of their employment with the District.

17. Subcontractors:

NDS shall not engage any subcontractors to perform any of the services required of it under this Agreement without the prior written consent of District. MVR shall notify District no later than ninety (90) Days prior to the date on which it proposes to enter into a subcontract. District may approve or deny any such request at its sole discretion.

18. Notices:

All notices which may be given hereunder shall be in writing and shall be mailed, postage prepaid, certified mail to the other party at such address. Any notice mailed within the County of Marin shall be deemed to have been delivered upon the following business day. Any notice mailed from outside the County of Marin shall be deemed given five (5) days after having been sent. Either Party by notice to the other Party may change the address for delivery of any such appropriate notice to the other party.

Unless otherwise notified, address for District shall be as follows:

Sanitary District No. 5 of Marin County
P.O. Box 227
Tiburon, CA 94920

And address for MVR shall be as follows:

Mill Valley Refuse Service
112 Front Street
San Rafael, CA 94901

19. Entire Agreement:

This Agreement represents the entire understanding of the Parties regarding the subject matter contained herein and supersedes all prior negotiations and agreements, either written or oral.

20. Amendment:

Any modification to this Agreement must be in writing, signed by both Parties.

21. Governing Law; Jurisdiction:

This Agreement shall be governed by, and construed and enforced in accordance with, the laws of the State of California. Any lawsuits between the Parties arising out of this Agreement shall be brought

and concluded in the courts of the State of California, which shall have exclusive jurisdiction over such lawsuits. With respect to venue, the Parties agree that this Agreement is made in and will be performed in Marin County.

22. Parties in Interest:

Nothing in this Agreement is intended to confer any rights on any Persons other than the Parties to it and their permitted successors and assigns

23. Severability:

If any non-material provision of this Agreement is determined by a Court of competent jurisdiction to be void and unenforceable as a matter of law, the remaining provisions herein shall continue in full force and effect.

24. Interpretation:

This Agreement shall be interpreted and construed reasonably and neither for nor against either Party, regardless of the degree to which either Party participated in its drafting.

IN WITNESS WHEREOF, the Parties have executed this Agreement upon the date above written.

Sanitary District No. 5 of Marin County

By:

Date

Printed:

Mill Valley Refuse Service

By:

Date

Printed:
