

**SANITARY DISTRICT NO. 5 OF MARIN COUNTY  
2001 Paradise Drive  
Tiburon, California 94920**

**AGENDA**

**Capital Improvement Program Committee Meeting  
Tuesday May 10, 2022, 5:00 p.m.**

**CORONA VIRUS (COVID-19) ADVISORY NOTICE**

Consistent with Assembly Bill 361 revising Government Code section 54953, and Resolution No. 2021-07 of this Board enacted in accordance therewith, the Meeting will not be physically open to the public and all Board Members and Staff will be teleconferencing into the meeting.

**How to Submit Public Comments:**

Comments submitted prior to the commencement of the meeting will be presented to the Committee and included in the public record for the meeting.

**Public Comments are to be submitted via email to [rdohrmann@sani5.org](mailto:rdohrmann@sani5.org).**

In addition, members of the public who are calling-in will have the opportunity to provide public comments by following the steps below:

**How to Participate in the Meeting:**

**Join Zoom Meeting by clicking on the following link:**

**<https://us02web.zoom.us/j/6230620778>**

**Meeting ID: 623 062 0778**

**or join by phone:**

**Call in number: (669) 900-9128**

**Participant Code: 623 062 0778**

**I. Roll Call**

**II. Public Comments**

**III. New Business**

1. Review and discuss HDR proposal re Main Plant Digester Rehabilitation Project
2. Review and discuss radio quote/proposal from BearCom concerning emergency preparedness and improved staff communication
3. Review and discuss additional option for switch gear improvements, per Todd Beecher (electrical engineering consultant) memo
4. Verbal discussion of upcoming Main Plant Wet Weather Tank Rehabilitation Project
5. Verbal update re Main Plant Drain Line Rehabilitation Project

**IV. Adjournment**

*This Committee may be attended by Board Members who do not serve on this committee. In the event that a quorum of the entire Board is present, this Committee shall act as a Committee of the Whole. In either case, any item acted upon by the Committee or the Committee of the Whole will require consideration and action by the full Board of Directors as a prerequisite to its legal enactment. **Accessible public meetings:** Any member of the public who needs accommodations should email the Office Manager, at [rdohrmann@sani5.org](mailto:rdohrmann@sani5.org), who will use her best efforts to provide as much accessibility as possible while also maintaining public safety.*

April 29,  
**2022**



**Proposal**  
**Digester Cleaning and  
Rehabilitation Project**





April 27, 2022

Mr. Tony Rubio, District Manager  
Sanitary District No. 5 of Marin County  
P.O. Box 227 / 2001 Paradise Drive  
Tiburon, CA 94920

**RE: HDR's Proposal for Digester Cleaning and Rehabilitation Project**

Dear Mr. Rubio:

HDR is pleased to present our proposal to assist Sanitary District No. 5 of Marin County (District) with providing project design, contract bid specifications, and contract management of your upcoming digester cleaning and rehabilitation project.

HDR brings proven experience with both the District and with past similar digester cleaning and rehabilitation projects. Recent projects for the District include the (1) Biosolids Management and Future Biosolids Master Plan; (2) Collection System Master Plan; and (3) Alternative Energy Study. Similar digester cleaning and rehabilitation projects completed by our team include Camarillo Sanitary District, City of Midland, Charlotte Water, and City of Boise.

Mike Falk will serve as your project manager. Under his guidance, the project team will enjoy a cooperative, synergistic working relationship that will benefit the District through efficient design and optimal solutions. He will employ the same project management skills used on past projects where he kept the team on schedule and budget while keeping clients fully informed as to project status. Through kick-off and workshop meetings, open communication, and budget and schedule tracking, his management style leads to a "no surprises" design and extremely low change orders. He understands the importance of communication, not only with outside agencies, but also with internal staff at the District. Mike also has extensive expertise with construction sequencing and keeping wastewater treatment plants operational during construction. By selecting Mike as your project manager, the District will be assured of responsiveness, accurate cost estimates, budget management, schedule control, and a quality project.

Mike will be supported by a local team with expertise and long-term experience in wastewater treatment plant design and construction engineering. Scott Joslyn is especially important, as he was operations specialist during preparation of the District's biosolids master plan, as well as digester cleaning and rehabilitation projects for Camarillo Sanitary District and City of Midland.

Mr. Tony Rubio  
April 27, 2022  
Page 2

If you require any further information or have any questions regarding this proposal, please feel free to contact Mike at (916) 817-4916 or via email at Mike.Falk@hdrinc.com. We are excited about this opportunity to continue working collaboratively with the District on this project.

Sincerely,  
HDR ENGINEERING, INC.

Handwritten signature of Holly L.L. Kennedy in black ink.

Holly L.L. Kennedy, PE (CA)  
Senior Vice President

Handwritten signature of Michael W. Falk in blue ink.

Michael W. Falk, PE (CA)  
Project Manager

MWF:pk/22-10340597



# 1. Project Team

Successful completion of any project requires technical competence and managerial skills in the assigned personnel, development of a thorough work plan, and understanding of the client’s needs. For your project, we have assembled a team of highly qualified and experienced professionals whose skills meet these requirements, and whose qualifications and responsibilities are tailored to your project objectives.

## Current Composition of HDR’s Professional, Technical, and Support Staff

Founded in 1917, HDR has grown to a staff of more than 11,144 employee-owners located in over 200 offices worldwide. Table 1-1 shows the current composition of professional, technical, and support staff company wide. In Northern California, HDR maintains a professional staff of more than 500, of whom more than 100 specialize in water and wastewater engineering.

TABLE 1-1. COMPOSITION OF HDR STAFF	
Staff Type	Count
Administrative Support Workers	613
Executive/Senior Level Officials and Managers	40
First/Mid Level Officials and Managers	1,974
Laborers and Helpers	3
Professionals	7,164
Technicians	1,350
<b>Total</b>	<b>11,144</b>

## Proposed Staff

Figure 1-1 shows the proposed staff for your project. Qualifications, experience, and time commitment of key staff follow this page. Resumes are included in the appendix.

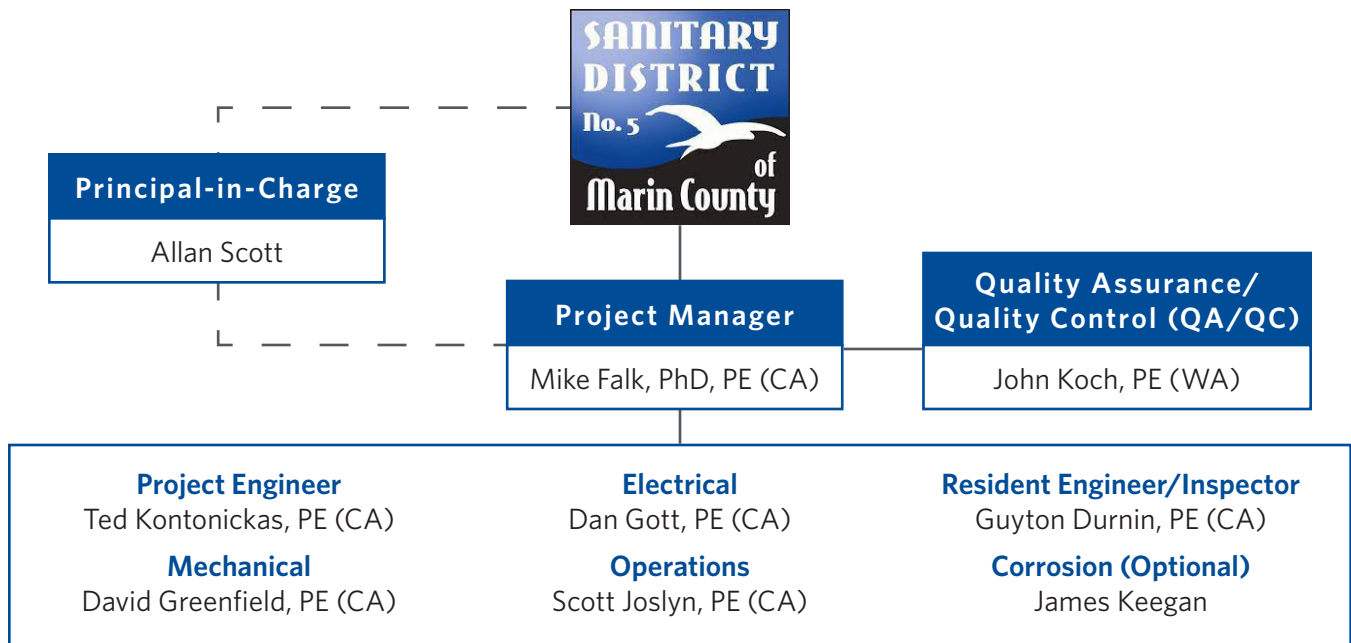

Figure 1-1. Project Team Organization



## Mike Falk, PhD, PE (CA)

*Project Manager*

### Related Qualifications and Experience

- More than 13 years of wastewater engineering experience.
- Project manager during preliminary design, detailed design, and engineering services during construction of concurrent improvement projects at Central Contra Costa Sanitary District's 55 mgd wastewater treatment plant, which include blower improvements, aeration basin diffuser replacement, seismic upgrades, and steam system improvements.
- HDR project manager for civil, process mechanical, structural, electrical, and process instrumentation preliminary design, final design, and engineering services during construction of primary sedimentation expansion and improvements at the wastewater treatment plant.

### Amount of Project Involvement

- 30 to 40%



"I wanted to take the opportunity to thank your team for pulling together another great nutrient Group Annual Report. We really appreciate your team's commitment to continuous improvement, in how you look for ways to make each year's submittal more useful than the last. As always, this year's report is a product that we can be proud to share with the SF Bay Water Board."

*~ Lorien Fono, Executive Director  
Bay Area Clean Water Agencies*



## Ted Kontonickas, PE (CA)

*Project Engineer*

### Related Qualifications and Experience

- More than 31 years of wastewater engineering experience
- Completed more than 50 wastewater treatment plant upgrade projects, 18 of which include digester upgrades
- Project manager during predesign and final design of digester piping improvements for the City of San Mateo's wastewater treatment plant.
- Project manager during predesign, detailed design, bidding, and engineering services during construction of Digester No. 1 mixing system improvements at the City of Watsonville's wastewater treatment facility.

### Amount of Project Involvement

- 35 to 45%



"Ted Kontonickas has great communication skill. He has an ability to always get back with me and resolve the problem. He works within the budget and makes sure we stay within budget."

*~ Vaughn Fleischbein, Senior Civil Engineer  
City of Folsom*



**John Koch, PE (WA)**  
QA/QC

**Related Qualifications and Experience**

- More than 53 years of wastewater engineering experience.
- Project manager, project engineer, QA/QC reviewer, or technical advisor on more than 100 wastewater treatment plant projects.
- Involved in more than 25 new and rehabilitated digester projects, including the Charlotte Water, Johnson County Wastewater, City of Gillette, and City of Boise projects featured in Section 2 of this proposal.

**Amount of Project Involvement**

- 5 to 10%



“John Koch is very proactive, very conscientious, and very thorough.”

~ Dave Moss  
Spokane County



**David Greenfield, PE (CA)**

*Mechanical*

**Related Qualifications and Experience**

- More than 19 years of wastewater engineering experience on more than 20 water and wastewater treatment plant projects.
- Mechanical design of digester piping improvements for the City of San Mateo.
- Project manager for predesign (including outage plan), detailed design, bidding, and engineering services during construction of biogas treatment system improvements at Dublin San Ramon Services District.
- Provided business case evaluation, preliminary design, detailed design, bidding, and engineering services during construction for improvements to the digester gas management system at the Regional San’s 181 mgd Sacramento Regional Wastewater Treatment Plant.

**Amount of Project Involvement**

- 20 to 30%



**Dan Gott, PE (CA)**  
*Electrical*

**Related Qualifications and Experience**

- More than 29 years of experience as an electrical engineer for wastewater facilities.
- Electrical engineer on more than 40 wastewater treatment plant projects.
- Electrical design of digester piping improvements for the City of San Mateo’s wastewater treatment plant.
- Electrical engineer during design and construction of Digester No. 1 mixing system improvements at the City of Watsonville’s wastewater treatment facility.



“Don and I had a good experiences with HDR on the FOG project and would like to work you on future projects.”

~ Thomas Lam  
City of Hayward



## 1. Project Team

Sanitary District No. 5 of Marin County | Digester Cleaning and Rehabilitation Project



### Scott Joslyn, PE (CA)

*Operations*

#### Related Qualifications and Experience

- More than 31 years of operations/startup experience on more than 40 treatment plants, 24 of which included digester cleaning, rehabilitation, and upgrades.
- Certified Grade V wastewater treatment plant operator.
- Operations specialist during virtually identical digester cleaning and rehabilitation projects for Camarillo Sanitary District and City of Midland.
- Operations specialist during preparation of biosolids master plan for Sanitary District No 5 of Marin County.

#### Amount of Project Involvement

- 20 to 30%



"I've never had the pleasure of working with such a great consulting team before. I trust you to always look out for the District and have been very impressed with the work [Guyton], Scott, and now Shay are doing for us. Your professionalism is excellent and we look forward to you continuing to help us in the future!"

*~ Hamid "Saeed" Parsa, Senior Engineer  
Mountain House Community Services District*



### Guyton Durnin, PE (CA)

*Resident Engineer/Inspector*

#### Related Qualifications and Experience

- More than 15 years of engineering and management experience on infrastructure projects, with a focus on water and wastewater.
- Resident engineer for Mountain House Community Services District's \$33 million Phase 3 Mountain House Water Reclamation Facility expansion, which involved digester upgrades.
- Resident engineer for a variety of energy and sustainability projects at West County Wastewater District's Water Quality Resource and Recovery Plant, which include new digesters.

#### Amount of Project Involvement

- 50 to 100%



### Allan Scott

*Principal-in-Charge*

#### Related Qualifications and Experience

- More than 37 years of experience supporting water and wastewater utilities.
- Very familiar with Sanitary District No 5 of Marin County staff, having served as project manager for your collection system master plan.
- As principal-in-charge, he will make sure that the necessary HDR resources are available to the HDR project manager to carry out the project. In addition, Allan is available to the District's project manager as a second line of communication to HDR.

#### Amount of Project Involvement

- 5 to 10%



"Allan and his team have proved invaluable as we have put this program together and he has been a key contributor to our success in many ways. They have been very responsive and flexible, and consistently delivered the work promised."

*~ Bradley Rahrer  
City and County of Honolulu*



# 2. Project Experience and References

Similar projects that HDR has been involved with in the past four years are provided below. They include project descriptions, reference information, value of the work (HDR's fee), and a summary of HDR's involvement.



## City of Midland | Water Pollution Control Plant Expansion and Improvement

**Reference:** Mr. Cory Moose, Assistant Utilities Director, City of Midland, (432) 685-7937, cmoose@midlandtexas.gov

**HDR's Fee:** \$1,788,161

**Project Dates:**  
December 2016 to  
December 2020

HDR provided design, bidding, construction phase, and startup services for extensive rehabilitation throughout the water pollution control plant, which included digester rehabilitation, digester heating system, and primary clarifier effluent lines. The improvements included digester gas collection piping, methane and natural gas fired boilers, as well as electrical and SCADA upgrades.

HDR evaluated two existing cast-in-place concrete digesters that developed leaks, and both the interior and exterior surface were exposed to hydrogen sulfide attack and experienced frequent operating upsets due to ambient temperature fluctuations. A cost analysis was performed for the rehabilitation of the tanks versus a complete replacement. HDR provided recommendations for structural repairs to both the interior and exterior of the tank removal

of existing interior coating system and replacing with a new system and installation of an Exterior Finish Insulation System (EFIS). HDR was also responsible for the design upgrades and rehabilitation associated with the digester gas collection system sludge heating system as well as compressed air systems for biological processes and pump and valve operation, and coordinated the removal of two existing ram press screenings units and replacement with three new ram press units.

Prior to startup, HDR provided emergency support to services to recover digester from acid lock after overheating due to mechanical failure in heating system. HDR provided startup and operations assistance for rehabilitation of an existing anaerobic digester. The digester was taken out of service for cleaning and replacement of aging components.



## 2. Project Experience and References

Sanitary District No. 5 of Marin County | Digester Cleaning and Rehabilitation Project



### Camarillo Sanitary District | Digester Cleaning

HDR developed a temporary solids management operating plan (high level) that can be implemented during the upcoming planned digester cleaning, condition assessment, and repair. HDR conducted a preliminary condition assessment of the exterior of the two digesters in 2020 and determined an estimated remaining useful life of five years. HDR developed recommendations for basic repairs of delaminated concrete, cracks, joints, and exposed rebar that can be performed by the cleaning contractor while on-site.

**Reference:** Mr. Darrin Carter, Water Reclamation Superintendent, Camarillo Sanitary District, (805) 383-5665, [dcarter@cityofcamarillo.org](mailto:dcarter@cityofcamarillo.org)

**HDR's Fee:** \$106,000

**Project Dates:** November 2021 to January 2022, March 2022 to August 2022



### City of San Mateo | Digester Piping Improvements

HDR provided final design, bidding, and engineering services during construction of digester piping Improvements, which included adding an overflow pipe from Digester No. 1 to the sludge storage tank, adding foam suppression pump into pump manifold, and adding suction piping manifold for digested sludge pumps (to transfer sludge from digester to sludge storage tank).

HDR subsequently designed improvements to replace selected exposed and buried sludge piping between Digester No. 1, Digester No. 2, and the Digester Control Building. These existing digester piping was impacted by struvite, causing reduced flow and increased operations and maintenance (O&M). The replacement with smooth wall pipes will prevent future struvite deposition and allow for easier cleaning.

**Reference:** Mr. Dan Patten, Project Manager, City of San Mateo, (650) 522-7284, [dpatten@cityofsanmateo.org](mailto:dpatten@cityofsanmateo.org)

**HDR Fee:** \$84,005

**Project Dates:** March 2018 to Present



### City of Watsonville | Digester No. 1 Mixing System at the Wastewater Treatment Facility

HDR provided design, bidding, and engineering services during construction for the repackaging of the previous HDR design in 2017, which included the new mixing system and pump for the digester for a base bid. The design included repairing cracks, adding Enduraflex coating for the Digester No. 1 roof, adding piping and valves to feed Digester No. 2 from the existing FOG system, and adding a mixing system for Digester No. 1 at the wastewater treatment facility.

**Reference:** Mr. Kurtis Cotton, Principal Engineer, City of Watsonville, (831) 768-3116, [kurtis.cotten@cityofwatsonville.org](mailto:kurtis.cotten@cityofwatsonville.org)

**HDR's Fee:** \$243,392

**Project Dates:** March to January 2018, June 2021 to May 2023





## City of Gillette | Wastewater Facility Improvements

HDR provided preliminary design, final design, bidding, and construction phase services for improvements at the wastewater treatment plant, which included new septage receiving facility, primary digester cover replacement, ultraviolet (UV) disinfection, dewatering, waste activated sludge (WAS) thickening, underground piping and valves, electrical campus and building power, yard waste/compost/roads, and miscellaneous mechanical work.

Digester improvements included waste gas burner replacement, gas mixing blowers, relocation of blowers, new electrical for blowers, new lighting, and replacement of boiler unit, valves, pumps, and HVAC in digester/energy buildings.

**Reference:** Mr. Levi Jensen, Senior Civil Engineer, City of Gillette, (307) 687-2534, levij@gillettewy.gov

**HDR's Fee:** \$2,195,949

**Project Dates:** August 2020 to August 2023

## City of Portland | Columbia Boulevard Wastewater Treatment Plant Digesters 1 and 2 Diffuser Replacement

The diffuser piping in Digesters 1 and 2 at Columbia Boulevard Wastewater Treatment Plant became corroded and needed to be replaced. HDR provided predesign, detailed design, bidding, engineering services during construction, and startup assistance for the recommended improvements, which included replacement of the valves associated with the diffuser piping in the digester pump house basement, piping between digester pump house and digesters, and piping inside the digesters.

**Reference:** Ms. Chris Selker, Project Manager, City of Portland, (503) 823-2482, chris.selker@portlandoregon.gov

**HDR's Fee:** \$69,208

**Project Dates:** March 2017 to August 2019

## City of Helena | Digester Rehabilitation

HDR inspected and evaluated the existing structural and mechanical components of the secondary digester and provided preliminary design, final design, bidding, and construction phase services for the replacement of the failed digester cover and lining of the existing concrete structure. HDR inspected the digester basin, performed a LiDAR scan, and provided procurement documents for the city to purchase the digester cover. Project documents were provided for repair and lining of the concrete basin and exposed rebar, replacement of the existing digester cover with a new floating steel cover, new digester gas piping, and reconfiguration of the gas piping to match the West basin piping configuration.

**Reference:** Mr. Ryan Leland, Public Works Director, City of Helena, (406) 447-8433, rleland@helenamt.gov

**HDR's Fee:** \$402,413

**Project Dates:** January 2019 to July 2021



## 2. Project Experience and References

Sanitary District No. 5 of Marin County | Digester Cleaning and Rehabilitation Project



### Charlotte Water | McAlpine Creek Digester Rehabilitation

HDR provided condition assessment, preliminary design, detailed design, bidding, and construction phase services for the rehabilitation of the digestion system complex at McAlpine Creek Wastewater Management Facility.

Processes and facilities that were evaluated included: Digester Control Building 1 and ancillary systems; Digester Nos. 1-4 (2 MG each); Digester Control Building 2 and ancillary systems; Digester Nos. 5-8 (2 MG each); Digester biogas conditioning facility and waste gas burners; digested sludge storage tank control building/pumping station and ancillary systems; and Digested Sludge Storage Tanks No. 1 and 2 (1.7 MG each) This condition assessment encompassed the boilers, hot water conditioning and pumping systems, digester mixers, heat exchangers, pumps, grinders, biogas compression, biogas safety components, biogas pipes/valves/blowers/flare, biogas conditioning equipment,

electrical gear, instruments, floating and concrete lids, mechanical/ architectural/ structural elements.

Improvements valued at \$10.1 million in construction cost were subsequently designed, and included: (1) replacement of Digested Sludge Storage Tank No. 1, digested sludge recirculation pumps, waste gas burners, media in biogas scrubber nos. 7-9, digester mixer nos. 5-8 oil piping, valves, boiler building, hot water circulation pumps and control valves, digester no. 4 access cover, carbon steel biogas piping and components, sump pump and trench drains, and biogas scrubber nos. 1-9; (2) replacement of rehabilitation of digester mixer no. 8; (3) modification of launder seal system; (4) upgrade of biogas traps and automate trap primer and digester mixer electrical and instrumentation; (5) repair/ replacement of digested sludge grinder; automation of digester nos. 5-8 emergency overflow trap primer; (6) digested sludge control building brick veneer improvements; and (7) coatings. The mixer, biogas piping, and underside of the cover, interior concrete, and brick and mortar down the corbel ledge needed to be cleaned and repaired

**Reference:** Mr. Kit Eller, Senior Project Manager, Charlotte Water, (704) 336-1031, keller@charlottenc.gov

**HDR's Fee:** \$1,640,340

**Project Dates:** July 2017 to March 2023



### City of Kalispell | Secondary Digester Improvements

HDR evaluated improvements to the city's secondary digesters. The evaluation included condition assessment of the secondary digesters, gas piping, digested sludge pipe, and digester mixing/wasting pumps to develop alternatives for repair or replacement. Rehabilitation of the floating digester covers was recommended. The existing coatings were removed and new high performance protective coatings applied. In addition to design and bidding services, HDR also provided onsite construction observation. Construction services included inspection of surface preparation at coating hold points, dry film thickness measurements, holiday testing, and weld inspection.

**Reference:** Mr. Aaron Losing, Plant Manager, City of Kalispell, (406) 758-5070, alosing@kalispell.com

**HDR's Fee:** \$319,517

**Project Dates:** May 2016 to August 2022





## Orange County Sanitation District | Digester Rehabilitation

HDR provided condition assessment, preliminary design, final design, bidding, and construction phase services for the rehabilitation improvement to Digesters C, D, F, and G, which included four high-rate mixing pumps, two sludge transfer pumps, four heat exchangers, associated heat exchanger piping, four heated sludge recirculation pumps, four hot water pumps, associated hot water piping, and the electrical and instrumentation systems associated with this equipment.

**Reference:** Mr. Andrew Brown, Engineer, Orange County Sanitation District, (714) 962-2411, [abrown@ocsan.gov](mailto:abrown@ocsan.gov)

**HDR's Fee:** \$210,608

**Project Dates:** March 2021 to December 2022

## Charlotte Water | McDowell Creek Phase II Reliability Improvements

HDR performed a condition assessment, design, permitting assistance, bidding, and construction phase services for digester rehabilitation improvements that included replacing floating steel covers with concrete domes, replacing of mixing system with internal draft tube mixers, replacement of digester gas accessories, new internal piping inside digester, repair of digester concrete cracks and concrete, calcium aluminate overlay on walls and floor, and replacement of the pressure level elements, digester gas flow meters, electrical breaker box, guardrail, exhaust fans, built-up roofing, makeup air handler, mag meter to drying beds, digester gas sediment traps, methane analyzers, feed digester valve actuators, and sump pumps. The digester improvements allowed Digester 5 to be cleaned and inspected.

**Reference:** Mr. Chuck Cowherd, Senior Engineer, (704) 391-5101, [ccowherd@charlottenc.gov](mailto:ccowherd@charlottenc.gov)

**HDR's Fee:** \$1,181,635

**Project Dates:** March 2017 to September 2021

## Johnson County Wastewater | Tomahawk Creek Wastewater Treatment Facility, Improvements, Detailed Design

HDR provided preliminary design, final design, permitting, bidding, and construction phase services for \$230 million in modifications and improvements to the 19 mgd Tomahawk Creek Wastewater Treatment Facility, which included modifications to the existing digester complex. The mechanical systems associated with the digestion process (e.g., pumps, mixers, boilers) were old and beyond repair. The tank covers and concrete structures had corrosion damage, requiring replacement of the covers and repair of sections of the tank feed/overflow boxes.

**Reference:** Ms. Susan Pekarek, Chief Engineer, Johnson County Wastewater, (913) 715-8553, [susan.pekarek@jcw.org](mailto:susan.pekarek@jcw.org)

**HDR's Fee:** \$9,184,745

**Project Dates:** August 2013 to July 2018



## 2. Project Experience and References

Sanitary District No. 5 of Marin County | Digester Cleaning and Rehabilitation Project



### City of Boise City | Digester Cleaning and Improvements

**Reference:** Mr. Tony Perreira, Project Manager, City of Boise, (208) 384-3799, [aperreira@cityofboise.org](mailto:aperreira@cityofboise.org)

**HDR's Fee:** \$2,143,820

**Project Dates:** August 2015 to October 2019

HDR provided preliminary design, final design, bidding, and construction phase services for the expansion of anaerobic digestion process (adding 4th digester) at West Boise Water Renewal Facility. Evaluation during preliminary engineering included tank orientation (egg shape, tall slender, short squat), mixing types (linear motion, pumped mixing, single paddle type), heating methods (internal heating coils vs. external heat exchanger), and cover arrangement. After the decision was made to defer construction of a 4th digester, HDR developed design and specifications to allow parallel digester flow operation to allow Digester 3 to be removed from service for cleaning.

Digesters No. 1, 2, and 3 were upgraded to provide both series and parallel modes of operation. Design and construction of the modifications to the instrumentation and control system, piping, and valves were completed by HDR, which enabled parallel digester operation. Digesters No. 1 and 2 were cleaned and inspected in the

fall of 2017, and Digester No. 3 has not been cleaned since it was constructed in 2010.

To clean Digester No. 3, it was necessary to construct a drying bed area to allow for temporary storage of digested solids at the bottom of the digester cone area that are too thick to be dewatered through the existing belt filter press operation. Operation of the digestion process was changed to a 50/50 parallel flow operation to Digesters No. 1 and No. 2, allowing Digester No. 3 to be taken offline to complete the cleaning and condition assessment work effort. The digested solids from Digester No. 3 were cleaned out and were pumped and stored in the drying beds as part of the digester cleaning.

# 3. Scope of Work and Estimated Cost

## Scope of Work/Assumptions

We have prepared the following scope of work and assumptions when developing our estimated cost for the delivery of design, bid package preparation, and contract management of the digester cleaning and rehabilitation project. We have identified optional tasks that we believe will add value to the District's project. Also included in this section is our proposed scope of work/assumptions and cost for construction phase services.

### Task 1 – Information Review, Staff Interviews, and Equipment Inventory

The purpose of this task is to compile and review District-provided information and documents relevant to the digesters to gain a thorough understanding of existing operational mode, condition, issues, needs, and schedule required to take digesters out of service, including dewatering, while keeping one digester in service.

#### Subtask 1.1 – Kick-off Meeting and Staff Interviews

HDR will meet with the District management and operators to introduce the project team, collect background information, discuss the District's project goals and objectives, and establish lines of communications. The kick-off meeting will focus on getting the remaining issues on the table, discussing potential alternatives and resolutions, preparing a detailed and concise action plan, list of needed information and data, defined schedule, and list of participants with their assignments.

Following the kick-off meeting, HDR will tour the digestion facilities to collect additional details required to support the design effort.

It is assumed the kick-off meeting/site visit and staff interviews will be conducted on the same day. Up to three HDR team members will attend the meeting and interview staff. Up to eight hours for each team member has been budgeted for this subtask.

COVID-19 protocols to be followed for the in-person meeting and site visit, if still applicable.

**Deliverables:** Meeting agenda, minutes, action plan, and schedule.

#### Subtask 1.2 – Document and Data Review

HDR will review the following documents and data provided by the District and develop a draft sequence of work that will provide a foundation for the remainder of the project.

- Plant Operations Manual
- Schematics of digester piping from 1980s Carollo as-built drawings
- Operational dewatering capability by staff
- List of equipment and piping the District plans to purchase pre-bid due to long lead times.

Prior to the meeting, HDR will support an operations effort to optimize the dewatering process for maximum throughput to support developing some of the operational time requirements for dewatering a digester.

#### Subtask 1.3 – Project Plan (Optional)

Using information developed in Subtask 1.1 and feedback from Subtask 1.2, HDR will develop a project plan that includes schematics and schedule to outline the District's effort and contractor's effort to clean and improve the existing anaerobic digesters. The project plan will have operating sequences with schematic details which will enable the District to accomplish digester dewatering and facilitate the selected contractor in such a way that they can complete their digester cleaning and rehabilitation work on time. The plan will also outline accommodations for safety so responsibilities for specific work tasks are understood, District staff knows what needs to be done, and the design engineer knows what needs to be specified. This specific effort allows plant staff to help reduce project costs, as well as prevent the expensive





### 3. Scope of Work and Estimated Cost

Sanitary District No. 5 of Marin County | Digester Cleaning and Rehabilitation Project

problem of scope gap between the owner and cleaning contractor.

Specific information that needs to be developed and understood, especially roles and responsibilities, for the successful completion of the project includes:

- Early work repairs or improvements needed to enable project.
- Plan for operating dewatering to remove as much easy liquid material out of secondary digester. Options to investigate include twice per day roll off bin pickup and extending operating hours to accelerate timeline.
- Primary digester isolation, feeding, and dewatering plan to maintain process during secondary digester work.
- Plan for secondary digester gas purge and opening process required by digester cleaning contractor.
- Plan for secondary digester cleaning staging and digester cleaning operations by contractor.
- Plan for secondary digester inspection.
- Safe rehabilitation of pipes and valves on secondary digester and between primary and secondary digester.
- Inert gas purge and seed of secondary digester from primary digester to enable it to serve as main process digester during primary digester cleaning.
- Secondary digester isolation, feeding, and dewatering plan to maintain process during primary digester work. Plan needs to consider digester process control and loading to prevent acid lock of process with the potential for holding waste activated sludge (WAS) in a temporary aerobic digester or raw dewatering until anaerobic digestion capacity is restored.
- Plan for operating dewatering to remove as much easy liquid material out of primary digester. Options to investigate include twice per day roll off bin pickup and extending operating hours to accelerate timeline.
- Plan for primary digester gas purge and opening process required by digester cleaning contractor.

- Plan for primary digester cleaning staging and digester cleaning operations by the contractor.
- Plan for primary digester inspection.
- Safe rehabilitation of pipes and valves between on primary digester and between primary and secondary digester.
- Inert gas purge and seed of primary digester from secondary digester to enable it to resume process responsibility of digesting all the plant biosolids.
- Loading plan to consider digester process control to prevent acid lock of process while processing stored inventory of biosolids.

**Deliverables:** Project plan in PDF format.

#### **Subtask 1.4 – Project Plan Adjustments and Training (Optional)**

HDR will adapt the project plan for conditions after contractor bidding and notice to proceed. HDR will provide training on project plan and digester process control to maintain successful operations during project. It is assumed HDR's operations specialist will provide the training during a single site visit (up to eight hours). COVID-19 protocols will be followed for the site visit, if still applicable.

**Deliverables:** Conformed project plan and digester and dewatering process control training.

### **Task 2 - Project Design, Bid Package Preparation, and Contract Management**

#### **Subtask 2.1 – Draft and Final Bid Package and Schedule**

HDR will prepare project design and bid package for the following improvements:

- Secondary Digester (sequenced first)
  - Secondary Digester taken out service and cleaned and inspected.
  - Anticipate that 2 to 4 feet of sludge will remain in secondary digester and contractor will have to dewater remaining and haul off site.
  - Digester cover and pipelines to digester to be inspected, cleaned, and repaired if necessary.



- Primary Digester (sequenced second)
  - Primary Digester will be taken out service and cleaned and inspected.
  - Anticipated that 2 to 4 feet of sludge will remain in primary digester and the contractor will have to dewater remaining and haul off site.
  - Digester cover and pipelines to digester to be inspected, cleaned, and repaired if necessary.

Drawings will be prepared in AutoCAD. Design plans will be developed utilizing industry standard scales, in English (not metric) engineering units. Up to 10 drawings are budgeted.

Specifications will be prepared in Construction Specifications Institute (CSI) format using Microsoft Word. Our budget for this task assumes that the District will prepare and provide a set of General Conditions and Special Provisions, bid form, example agreement and other “front-end” sections for HDR to incorporate into the bid set, and that HDR’s master specifications will be used as a basis for the technical provisions.

Engineer’s opinion of construction cost will be prepared in Microsoft Excel.

Draft drawings, specifications, engineer’s estimate of probable construction cost, and schedule will be submitted to the District for review and comment.

After incorporation of District comments on the draft design, HDR will prepare the final bid package for Board acceptance and approval.

**Deliverables:** PDF of draft and final half-size (11- x 17-inch) drawings, specifications, engineer’s opinion of construction cost, and schedule.

### **Subtask 2.2 – Review Meeting**

HDR will meet with District representatives to present the draft project and schedule and discuss comments. A review comments log will be kept to make sure design comments are incorporated. Design review comments will be encouraged and welcome from both District’s engineering and operations personnel.

Up to four HDR team members will attend the four-hour review meeting virtually. It is assumed WebEx or Microsoft Teams will be used.

**Deliverables:** Meeting agenda and minutes, and design review comments log.

### **Subtask 2.3 – Project/Contract Management During Design**

This subtask includes the management activities needed for on-time and on-budget project completion, and to address the District’s concerns. A project management plan will be developed to serve as a communication tool for District and HDR staff. HDR will prepare invoices, progress reports, and decision log updates on a monthly basis. The monthly progress reports will summarize budget and schedule status in measurable terms. Other activities include scheduling of staff and coordinating the quality assurance effort.

This subtask assumes contract/project management will be provided over a four-month period, from project initiation through completion of design.

**Deliverables:** Monthly progress reports, invoices, project management plan, and decision log.

### **Subtask 2.4 – Investigate Plant Improvements to Improve Digester Operations (Optional)**

HDR will conduct a feasibility investigation of either solids screenings or plant headworks that can be installed at plant to reduce the impact of rags on the digester operation. The feasibility study will consist of a technical memorandum describing the equipment manufacturers considered and, if deemed feasible, how the equipment could be installed at the facility, and a cost estimate to construct the improvement.

**Deliverables:** Technical memorandum in PDF format listing separately sludge screening manufacturers considered, and headworks manufacturers considered that have equipment that could reasonably be installed into the main plant.

### **Subtask 2.5 – Condition Assessment (Optional)**

Inspect the interior and exterior surfaces of the two digesters. It is assumed two people will be on site for three days to complete the inspection, and that a rope-rigging subconsultant will be needed. After completion of testing of the samples, a report will be developed for District review and



comment. COVID-19 protocols will be followed, if still applicable.

**Deliverables:** Technical report for the inspection findings and recommendations for repairs in PDF format.

### **Task 3 – Bid Period Services**

#### **Subtask 3.1 - Prebid Meeting**

HDR will assist the District with conducting a job walk and attend the prebid conference to meet with prospective contractors and answer contractor questions. COVID-19 protocols will be followed, if still applicable.

**Deliverables:** Pre-bid meeting minutes.

#### **Subtask 3.2 - Bidding Services**

HDR will provide assistance during the bidding period, which includes receiving and recording contractor questions, issuing addenda to the contract documents for distribution to plan and specification holders, assisting the District with evaluating the bids, reviewing the bids for conformance with the bid documents, and assisting the District by providing input in the awarding of the contract. The District will prepare, negotiate, and execute the construction agreement with the selected contractor.

**Deliverables:** Up to one addenda to the bid set of contract documents, bid tabulation sheet, written clarification of contractor questions, and recommendation for award letter.

### **Task 4 - Construction Management and Engineering Services (Optional)**

HDR requests that the scope of work and budget for this phase of work be re-evaluated once the design is completed.

#### **Subtask 4.1 - Preconstruction Meeting**

HDR will attend the pre-construction meeting and assist the District with initiation of the construction phase. One HDR team member will attend the up to two-hour meeting onsite. COVID-19 protocols will be followed, if still applicable.

**Deliverables:** Meeting notes.

#### **Subtask 4.2 - Contract Clarifications**

HDR will answer questions and provide written interpretations of the requirements of the contract

documents, and evaluate the acceptability of substitute materials and equipment. HDR will maintain the clarifications log for the District.

**Deliverables:** Up to five clarifications or responses to requests for information (RFIs), and clarifications log.

#### **Subtask 4.3 - Submittal Reviews**

HDR will review the contractor's submittals, including shop drawings and operations and maintenance (O&M) manuals, from the contractor as required by the technical specifications, for work related to HDR's scope of design services. HDR will review and accept the contractor submittals, such as shop drawings, product data, samples, and other data, for the limited purpose of checking for conformance with the design concept and the information expressed in the contract documents. This review will not include review of the accuracy or completeness of details, such as quantities, dimensions, weights or gauges, fabrication process, construction means or methods, coordination of the work with other trades, or construction safety precautions, all of which are the sole responsibility of the contractor.

HDR's review will be conducted with reasonable promptness while allowing sufficient time in HDR's judgment to permit adequate review. Review of a specific item will not indicate that HDR has reviewed the entire assembly of which the item is a component. HDR will not be responsible for any deviations from the contract documents not brought to the attention of HDR in writing by the contractor. HDR will not be required to review partial submissions nor those for which submissions of correlated items have not been received.

HDR will maintain the submittal log for the District.

**Deliverables:** Up to five submittals/resubmittal reviews, and submittal log.

#### **Subtask 4.4 - Contract Change Orders and Potential Changes**

HDR will review potential contract change orders (PCOs) and other potential project changes prepared by the contractor. PCOs that are found to be applicable will be forwarded to the District for review and approval.

**Deliverables:** Up to one potential change item and one change order.

### Subtask 4.5 - Construction and Special Meetings

HDR will visit the construction site to assist the District with reviewing the acceptability of the work and resolve field problems. It is assumed that District personnel will be available to co-attend these meetings. It is assumed that the HDR inspector will attend the construction meetings (budgeted under Subtask 4.6) virtually or in-person if the site visit occurs on the same day as the meeting.

HDR also recommends attendance at the following special meetings:

- Secondary Preconstruction (walk-through LOTO, verify materials, and check schedules)
- Secondary Inspection results and repair plan
- Secondary work completed inspection, gas purge, and startup plan
- Primary Preconstruction (walk-through LOTO, verify materials, check schedules)
- Primary Inspection results and repair plan
- Primary work completed inspection, gas purge, and startup plan
- Three other meetings

One HDR team member will attend each special meeting for up to four hours in length. COVID-19 protocols will be followed, if still applicable.

**Deliverables:** Meeting notes.

### Subtask 4.6 - Construction Observation

HDR will perform on-site observations to check the quality and quantity of the work performed by the contractor to assist the District with guarding against defects and deficiencies in the work. The budget for this task is based on 36 total site visits (one site visit per week for 36 weeks). HDR's inspector will also take construction photographs to document the progress and any special situations. Construction photographs will be stored and provided to the District in digital format at the close of the project.

**Deliverables:** Construction observation logs and digital construction photographs.

### Subtask 4.7 - Progress Payments

HDR will review progress pay requests prepared by the contractor prior to submitting them to the District for review, approval, and processing for payment. HDR will negotiate discrepancies, if necessary, and make recommendations for the District for approval when complete.

**Deliverables:** Processing of up to 10 progress payment requests.

### Subtask 4.8 - Startup and Testing, and Project Closeout

HDR will oversee facility startup and testing, and help address operational and performance problems identified during startup. HDR and the District will jointly conduct a final inspection prior to startup, and HDR will prepare the final punch list for District review and approval prior to submitting it to the contractor for completion of the identified items. The District will process the project closeout documentation, including any release of retentions and bonds, and the Notice of Completion.

The budget for this task is based on eight site visits by HDR's operations specialist. COVID-19 protocols will be followed, if still applicable.

**Deliverables:** PDF of a final inspection punch list and startup testing and acceptance report.

### Subtask 4.9 - As-Built/Record Drawings

HDR will provide final record drawings based on the contractor prepared as-built drawings.

**Deliverables:** PDF of full-size and half-size sets of as-built record drawings.

### Subtask 4.10 – Project/Contract Management During Construction

HDR will provide contract management during the construction phase of the project, which is assumed to occur over a nine-month period.

HDR will prepare invoices and progress reports on a monthly basis.

**Deliverables:** Monthly progress reports and invoices.

## Estimated Cost

Table 3-1 on the following page shows the estimated cost to perform the scope of work described above.

TABLE 3.1 - ESTIMATED WORK EFFORT AND COST

Task No.	Task Description	Principal/ QA/QC	Project Manager	Project Engineer	Staff Engr	Mech Engr	Elect Engr	Ops	Corrosion	CM/ Inspector	CADD Tech	Admin/ Clerical	Total HDR Labor Hours	Total HDR Labor (\$)	Total HDR Expenses (\$)	Subs (\$)	Total Cost (\$)
<b>Task 1 - Information Review, Staff Interviews, and Equipment Inventory</b>																	
1.1	Kick-off Meeting and Staff Interviews		8	8				8	8				32	\$8,582	\$600		\$9,182
1.2	Document and Data Review		4	8	16	16		8	4				56	\$12,991			\$12,991
1.3	Project Plan (Optional)		2	8	8	8		8					34	\$8,307			\$8,307
1.4	Post Bid Project Plan Adjustments and Training (Optional)				4	4		8					16	\$3,661	\$200		\$3,861
	<b>Subtotal Task 1</b>	<b>0</b>	<b>14</b>	<b>24</b>	<b>28</b>	<b>28</b>	<b>0</b>	<b>32</b>	<b>12</b>	<b>0</b>	<b>0</b>	<b>0</b>	<b>138</b>	<b>\$33,542</b>	<b>\$800</b>	<b>\$0</b>	<b>\$34,342</b>
<b>Task 2 - Project Design, Bid Package Preparation, and Contract Management</b>																	
2.1	Draft and Final Bid Package and Schedule	12	16	44	44	24	10				64	20	234	\$52,688	\$200		\$52,888
2.2	Review Meeting		4	8		4	4	8					28	\$7,845			\$7,845
2.3	Project/Contract Management During Design	2	16									12	30	\$7,721	\$100		\$7,821
2.4	Investigate Plant Improvements to Improve Digester Operations (Optional)	2		8	16	8	8	16					58	\$13,747			\$13,747
2.5	Condition Assessment Inspection and Report (Optional)	2	4						94				100	\$18,892	\$3,000	\$17,850	\$39,742
	<b>Subtotal Task 2</b>	<b>18</b>	<b>40</b>	<b>60</b>	<b>60</b>	<b>36</b>	<b>22</b>	<b>24</b>	<b>94</b>	<b>0</b>	<b>64</b>	<b>32</b>	<b>450</b>	<b>\$100,892</b>	<b>\$3,300</b>	<b>\$17,850</b>	<b>\$122,042</b>
<b>Task 3 - Bid Period Services</b>																	
3.1	Prebid Meeting		6										6	\$2,108	\$100		\$2,208
3.2	Bidding Services (up to 1 addenda)		4	6	6	6					8	6	36	\$7,855			\$7,855
	<b>Subtotal Task 3</b>	<b>0</b>	<b>10</b>	<b>6</b>	<b>6</b>	<b>6</b>	<b>0</b>	<b>0</b>	<b>0</b>	<b>0</b>	<b>8</b>	<b>6</b>	<b>42</b>	<b>\$9,962</b>	<b>\$100</b>	<b>\$0</b>	<b>\$10,062</b>
<b>TOTALS WITH OPTIONAL TASKS</b>		<b>18</b>	<b>64</b>	<b>90</b>	<b>94</b>	<b>70</b>	<b>22</b>	<b>56</b>	<b>106</b>	<b>0</b>	<b>72</b>	<b>38</b>	<b>630</b>	<b>\$144,397</b>	<b>\$4,200</b>	<b>\$17,850</b>	<b>\$166,447</b>
<b>TOTALS WITHOUT OPTIONAL TASKS</b>		<b>14</b>	<b>58</b>	<b>74</b>	<b>66</b>	<b>50</b>	<b>14</b>	<b>24</b>	<b>12</b>	<b>0</b>	<b>72</b>	<b>38</b>	<b>422</b>	<b>\$99,789</b>	<b>\$1,000</b>	<b>\$0</b>	<b>\$100,789</b>

<b>Task 4 - Construction Management and Engineering Services</b>																	
4.1	Preconstruction Meeting			6									6	\$1,772	\$100		\$1,872
4.2	Contract Clarifications (up to 5 RFIs)				20							4	24	\$3,729			\$3,729
4.3	Submittal Reviews (up to 5 Submittals/Resubmittals)				20	10						4	34	\$6,287			\$6,287
4.4	Contract Change Orders and Potential Changes (up to 1)			4	8							1	13	\$2,599			\$2,599
4.5	Construction and Special Meetings (up to 9)			24	24	24							72	\$17,109	\$800		\$17,909
4.6	Construction Observation									288			288	\$69,107	\$3,600		\$72,707
4.7	Progress Payments									5			5	\$1,200			\$1,200
4.8	Startup and Testing, and Project Closeout							64					64	\$16,601	\$800		\$17,401
4.9	As-Built/Record Drawings				4						20		24	\$4,591			\$4,591
4.10	Project/Contract Management During Construction		27									18	45	\$11,928	\$200		\$12,128



# Appendix

## Resumes



**Michael W. Falk, Jr., PhD, PE (CA)**  
Project Manager

Mike has more than 13 years of water and wastewater engineering experience, with specialized expertise in nutrient removal process design, nutrient regulations, and energy optimization at wastewater treatment facilities. His experience is exceptionally broad with background on master planning, nutrient regulations, process design, energy audits and optimization, plant wide modeling, emerging technologies evaluation, and developing strategies for meeting low level nutrient discharge permits.

**SELECT RELEVANT EXPERIENCE**

**EDUCATION**

Doctor of Philosophy, Civil & Environmental Engineering, University of California, Davis, 2009

Master of Science, Environmental Engineering, University of Massachusetts, 2002

Bachelor of Science, Civil Engineering, Virginia Polytechnic Institute and State University, 1999

**REGISTRATION**

Professional Engineer, Civil | California No. C-77787

**CERTIFICATIONS**

Institute for Sustainable Infrastructure (ISI)  
Envision Sustainability Professional

**HDR TENURE**

13 Years

**INDUSTRY TENURE**

13 Years

**Blower Improvements | Central Contra Costa Sanitary District, Martinez, California**

Project manager for design of blower improvements for the 55 mgd wastewater treatment plant, which included adding two new electric blowers in the pump and blower building, refurbishing/replacing the existing electric blower, adding a new dedicated blower for pre-aeration at the headworks for grit removal, adding a new dedicated blower for north mixed liquor channel, adding a new dedicated blower for south mixed liquor channel (which also provides air to the nearby effluent-channel), replacing the aeration system air filtration system with a new unit to condition the air upstream of the aeration blowers; and providing electrical feed and control for the above listed equipment.

**Wastewater Treatment Plant Primary Sedimentation Expansion and Improvements | Dublin San Ramon Services District, Dublin, California**

HDR project manager for computational fluid dynamics (CFD) modeling, process analysis and design, civil, process mechanical, structural, electrical, and process instrumentation preliminary design, final design, and engineering services during construction of primary sedimentation expansion and improvements at the wastewater treatment plant. This \$19 million project includes a new primary sedimentation tank and partially demolishing and replacing an existing one (including deepening it from 10 feet to 14 feet), adding an additional grit tank, replacing internal mechanisms of the three remaining/existing primary sedimentation tanks, and replacing the motor control center (MCC).

**Aeration Basins Diffuser Replacement and Seismic Upgrades | Central Contra Costa Sanitary District, Martinez, California**

Project manager for preliminary design of aeration basin improvements that include: (1) replacement of the existing aeration diffusers and removal of the existing plenum; (2) replacement of the return activated sludge (RAS) piping and aeration header at the final effluent channel; (3) electrical feed, instrumentation, and controls associated with the new aeration system, aeration header, and control valves, and the used and unused selector channels; (4) rehabilitation of the existing aeration basins, including the used and unused selector; and (5) further design development of the aeration header rehabilitation and 72-inch isolation valves versus aeration header replacement alternatives. HDR evaluated three fine bubble diffuser types (membrane disc,

ultrafine bubble, sock diffuser type), two aeration control valve/actuator types, four submersible mixer types (submersible, Invent, Enviromix, Flygt), and two aeration header alternatives. The project included visual condition assessment of the unused aeration basin selector, geotechnical investigation, seismic investigation of the aeration basin structure, process modeling, hydraulic modeling, equipment procurement, and bid phase services.

**Wastewater Treatment and Biosolids Facilities Master Plan | Dublin San Ramon Services District, Dublin, California**

HDR project manager during preparation of the district's wastewater treatment and biosolids facilities master plan. HDR assisted with condition assessment/asset management of the wastewater treatment plant and biosolids facility, provided input to the regulatory requirements technical memorandum (TM) to include Bay Area Clean Water Agencies (BACWA) activities and potential future nutrient requirements as well as risk factors and probabilities associated with each future nutrient requirement identified, assisted with emergency analysis of the energy and cogeneration systems as well as possible energy generation expansion alternatives, participated in a review panel (visioning panel workshop) to evaluate new developments and technologies in wastewater resource recovery facilities and recommend which of these technologies should be considered for the District future, identified and evaluated nutrient removal alternatives to achieve nutrient reduction goals consistent with the nutrient control study being completed for BACWA, provided assistance in identifying and evaluating biosolids management alternatives, provided assistance in assessing recycled water treatment alternatives, assisted with performing a control room spacing and staffing study, and provided quality assurance/quality control review of the existing facilities and capacity technical memorandum (TM), regulatory requirements. Resource recovery technologies that were evaluated for the visioning panel workshop included nutrient recovery, biosolids recovery, and beneficial usage, and water recovery for reuse, including indirect and direct potable reuse applications.

**Solids Conditioning Building Shutdown | Central Contra Costa Sanitary District, Martinez, California**

Project manager for a project that provided support for shutdown of the solids condition building, which included presenting at two full-day workshop with district staff that focus on solids conditioning building shutdown, and supporting as-needed equipment/process evaluations in the event that the solids conditioning building is shutdown during the seismic retrofit project (e.g., temporary steam system, temporary blower system, valving replacements).

**Emergency Backup Blowers and Air Distribution | Central Contra Costa Sanitary District, Martinez, California**

Project manager for evaluation and development of the emergency backup blowers and aeration delivery system design for the aeration basins and dedicated aeration facilities that include temporary aeration air header to supply backup air to aeration/nitrification (A/N) tanks and other aeration users (i.e., headworks, mixed liquor channels, and final effluent polishing channel), as well as electrical feed associated with the emergency backup blowers that will provide aeration at a minimum for the A/N tanks.

**Filtration Improvements (Contract 3) for Easterly Wastewater Treatment Plant Tertiary Project | City of Vacaville, California**

Designed filtration improvements for the Easterly Wastewater Treatment Plant, which included anaerobic digester facility upgrades.

**Phase 3 Mountain House Water Reclamation Facility Expansion Peer Review, Owner Representation, and Construction Phase Services | Mountain House Community Services District, Mountain House, California**

Project manager for independent peer review of the design plans and specifications prepared by another consultant for the Phase 3 expansion of the Mountain House Water Reclamation Facility from 3 to 4 mgd. The project included digester improvements.



## **Guyton W. Durnin, PE (CA)**

Resident Engineer/Inspector

Guyton has more than 15 years of engineering and management experience on infrastructure projects, with a focus on water and wastewater. With degrees in Civil Engineering (BS), Economics (BA), and Environmental Engineering (MS), he provides clients with insight into the economic, environmental, and social outcomes of alternatives.

Guyton originally worked for a general contractor building a \$100 million LEED Gold project for Rice University in which he had to interact daily with his subcontractors, field staff, and the architects. He is working as a field inspector on a raw water to treated water storage tank for Mountain House and will be a field inspector on Mountain House's wastewater treatment expansion.

### **EDUCATION**

Master of Science,  
Environmental  
Engineering, Rice  
University, 2009

Bachelor of Science,  
Civil Engineering, Rice  
University, 2006

Bachelor of Arts,  
Economics, Rice  
University, 2006

### **REGISTRATION**

Professional Engineer,  
Civil | California #77854

### **HDR TENURE**

2 Years

### **INDUSTRY TENURE**

15 Years

### **SELECT RELEVANT EXPERIENCE**

#### **\$33 Million Phase 3 Mountain House Water Reclamation Facility Expansion | Mountain House Community Services District, Mountain House, California**

Deputy project manager during construction management and inspection of the Phase 3 expansion of the Mountain House Water Reclamation Facility from 3 to 4 mgd. The project includes: (1) new influent lift station pumps and new parallel sewer forcemains; (2) headworks facility in a building, with two stage screening and grit removal; (3) new sludge handling equipment, including transfer pumps, polymer addition, centrifuge dewatering equipment, and conveyors; (4) retrofit of the existing sequential batch reactor (SBR) to membrane bioreactor (MBR), which included 4 subdivision of the secondary process tanks into 4 tanks, conversion of the existing surge tank to post-anoxic treatment, retrofit the existing surge pumps to internal recycle systems, and new aeration blowers; (5) conversion of the existing digesters to anoxic basins; (6) new control programming and changes to the process; (7) new MBR membrane filtration tankage for 7.2 mgd; (8) MBR treatment equipment building with permeate pumping equipment, air scour blowers, instrumentation, chemical injection day tanks, return activated sludge (RAS) return pumps, and associated MBR mechanical and electrical components; (9) changes to existing electrical and new electrical systems, including additional backup diesel generator, automatic transfer switch, and control system, as well as required system power, lighting recepts, bonding, and control electrical; (10) retrofit of the existing dissolved air floatation (DAF) clarifier systems to provide waste activated sludge (WAS) thickening prior to new aerated sludge storage; (11) new sludge storage systems under the combination headworks and sludge building, including digester blowers, aeration and mixing; (12) ultraviolet (UV) disinfection system; and (13) recycled water pumping and storage onsite. As deputy project manager, helped the project manager by reviewing the contract to create project control documents, reviewing costs on the project weekly and providing feedback for the monthly invoices, interfacing directly with the client, attending meetings, and taking meeting notes. Once construction starts, will be performing field inspection.



**Southeast Treatment Plant Headworks Facility | San Francisco Public Utilities Commission, San Francisco, California**

Office engineer during construction of a new \$225 million headworks facility and odor control structure at the Southeast Treatment Plant, which will minimize odors, meet seismic standards to better protect the facilities from earthquakes, improve operational reliability and flexibility, increase efficiency of treatment processes and protect downstream equipment, and achieve the adopted Levels of Service goals for wastewater treatment. The project included modifications to the Bruce Flynn Pump Station and facilities inside the Southeast Treatment Plant, modifications to the existing underground combined sewer system in the vicinity of Rankin Street and Evans Avenue, shifting the four traffic lanes on Evans Avenue to establish a safe construction zone, demolition of the old headworks facility located on Evans Avenue, and construction of the new headworks facility in the same area as the old facility.

**Water Quality Resource and Recovery Plant Energy and Sustainability Upgrades | West County Wastewater District, Richmond, California**

Resident engineer for a variety of projects at the Water Quality Resource and Recovery Plant, which include replacement of influent pumps and motors, new grit separation system, carbon redirection system, rotary drum thickeners, high efficiency aeration blowers, cogeneration system, new digesters, sludge centrifugal dewatering system, thermal sludge dewatering/drying, Richmond sludge piping upgrade, conversion of drying beds into equalization basins, renewable energy installations (at the district office, Atlas Road Pumping Station, Tara Hills Pumping Station, Lakeside Pumping Station, and wastewater treatment plant), lighting upgrades at district offices and wastewater treatment plant, and electric vehicle charging stations at the district office).

**Raw Water Storage Tank Conversion and Distribution Flow Meter | Mountain House Community Services District, Mountain House, California**

The raw water storage tank conversion included conversion of the existing raw 4 million-gallon water storage tank to a treated water storage tank and

new interconnecting pipework. The distribution flow meter project included removing buried 36-inch-diameter pipe (between existing isolation valves) and installing new pipework, flowmeter, and flowmeter vault. Both projects are located at the Mountain House Water Treatment Plant. As owner’s representative, reviewed submittals and requests for information (RFIs), inspected construction in the field, and communicated directly with owner. As deputy project manager, reviewed costs and invoices, and directed subcontractors.

**Nick C. DeGroot Water Treatment Plant Concrete Drying Beds | South San Joaquin Irrigation District, Manteca, California**

Office engineer during construction of improvements at the Nick C. DeGroot Water Treatment Plant, which included addition of two concrete drying beds, influent solids piping from pretreatment to the drying beds, decant structure with weir gate and effluent piping to existing effluent piping header, and access road improvements for access to the proposed drying beds.

**\$1.6 Million Rock Slough Fish Screen Improvements | Contra Costa Water District, Oakley, California**

Contra Costa Water District pulls in water from the Delta through fish screening system. Improvements were needed to make the system useable for the future. Improvements included two new boat ramps, relocation of the log boom to accommodate the boat ramp, three new fish screen rake heads, upgrade to four hydraulic power units, pulley and rail systems upgrades, and replacement of the local human machine interface (HMI) screens, bird deterrent structures, and site drainage improvements. As inspector, acted as owner’s representative to review construction in the field as well as make sure the district’s safety policies were followed.



**Daniel J. Gott, PE (CA, NV)**  
Electrical

Dan has more than 29 years of experience administering and directing all aspects of electrical, instrumentation, and control systems for water, wastewater, and industrial facilities and systems. His experience has included planning, design, programming and configuration, construction support, equipment inspection and testing, facility startup, and training in system operations and maintenance (O&M) for water, wastewater treatment plants and pumping stations. Electrical systems include power distribution at the medium voltage level down to component level. Control systems include both programmable logic controller (PLC)-based distributed control and central microcomputer-based systems. Instrumentation systems include full instrumentation design for both municipal and industrial water and wastewater systems. He has serviced as electrical engineer on more than 60 water and wastewater treatment plant projects nationwide.

**EDUCATION**

Bachelor of Science,  
Electrical Engineering,  
San Diego State  
University, 1992

**REGISTRATION**

Professional Engineer,  
Electrical | California  
#14788

Professional Engineer,  
Electrical | Nevada  
#19101

**PROFESSIONAL AFFILIATIONS**

International Society of  
Automation (ISA) -  
Member since 1995

Institute of Electrical  
and Electronics  
Engineers, Inc. (IEEE) -  
Member since 1991

**HDR TENURE**

15 Years

**INDUSTRY TENURE**

29 Years

**SELECT RELEVANT EXPERIENCE**

**Digester Piping Improvements | City of San Mateo, California**

Electrical design of digester piping Improvements, which included adding an overflow pipe from Digester #1 to the sludge storage tank, adding foam suppression pump into pump manifold, and adding suction piping manifold for digested sludge pumps (to transfer sludge from digester to sludge storage tank). Subsequently design electrical improvements to replace selected exposed and buried sludge piping between Digester No. 1, Digester No. 2, and the Digester Control Building.

**Digester No. 1 Mixing System at the City’s Wastewater Treatment Facility | City of Watsonville, California**

Electrical engineer during design of the replacement of the existing gas mixing system with a high-efficiency pump mixing system in 2017 to improve mixing efficiency and expand the fats, oils, and grease (FOG) receiving facilities to optimize mixing of the secondary digester to be able to feed FOG and/or food waste slurries to the secondary digester, for the production of more methane gas for cogeneration, and to increase revenue as a result of additional tipping fees. Improvements to the FOG receiving station included an additional 10,000-gallon storage tank, piping and necessary ancillary equipment. Due to the high cost of bids at the time, the project was not constructed. Four years later, in 2021, subsequently provided electrical design and engineering services during construction for the repackaging of the previous design, which included the new mixing system and pump for the digester for a base bid. The design included repairing cracks, adding Enduraflex coating for the Digester No. 1 roof, adding piping and valves to feed Digester No. 2 from the existing FOG system, and adding a mixing system for Digester No. 1 at the wastewater treatment facility.

**New Digester Gas Fueled Cogeneration Facility at the Budd Inlet Wastewater Treatment Plant | LOTT Alliance, Olympia, Washington**

Provided electrical design support for a new digester gas fueled cogeneration facility at the Budd Inlet Wastewater Treatment Plant. The first phase of the

project included analysis of digester gas production rates and gas quality, plant heat needs and electrical demands, and development of conceptual plans and specifications to support a guaranteed maximum price for the construction costs for the project. The second phase involved finalizing equipment selection and construction document preparation to provide a new digester gas treatment system, 335 kW reciprocating engine-generator, heat recovery systems for the engine package, two hot water boilers, all associated piping, valving, and controls.

**Phase 2 Michelson Water Reclamation Plant Expansion | Irvine Ranch Water District, Irvine, California**

Provided quality assurance/quality control (QA/QC) review of the instrumentation and control design of \$87.5 million Phase 2 capacity expansion, which included new influent sewers and headworks, expanded primary sedimentation, a new primary effluent pumping station, modified flow equalization basins, secondary treatment expansion with membrane bioreactors (MBRs), a new high-rate clarifier to treat filter backwash, a new ultraviolet (UV) disinfection system, chemical facilities, a new floodwall, new pumping and other ancillary facilities, and electrical modifications.

**Wastewater Treatment Plant Upgrade | Goleta Sanitary District, Goleta, California**

Provided electrical, instrumentation, and control design for the \$30.9 million upgrade of the wastewater treatment plant from partial secondary blended process to full secondary treatment using a roughing filter/activated sludge process. The roughing filter/activated sludge process includes 130-foot-diameter roughing filters followed by a 1.5 million-gallon activated sludge basin. Improvements also included conversion of one of the existing solids stabilization ponds into a 3.2 million-gallon flow equalization basin, new flow equalization pumping station, two new 80-foot-diameter secondary clarifiers, new solids handling facilities, headworks facility upgrade, new hot water boilers (dual-fuel) and enclosed flare waste gas burner, new 130-foot-diameter trickling filter with 10-foot wall and expansion of the height of the existing trickling filter wall by 2 feet to accommodate 8 feet of media, replacement of the existing activated carbon odor control system for the headworks facility and pumping station with vapor-phase biological odor

control, new odor control system for the new dissolved activated flotation tank facility, a shower and locker room building, and a new aeration building containing high-efficiency variable speed blowers and equipment required for the new aeration basins, motor control center (MCC), and 1,500 KW standby diesel engine generator system. Solids handling facilities included a sludge holding tank and dewatering building, two dissolved air flotation tanks to thicken waste activated sludge (WAS) and scum from the existing and new secondary clarifiers, a single solid-bowl centrifuge for dewatering, in-line grinder, polymer system, screw conveyors, storage hopper, and new sludge harvester.

**San Jose-Santa Clara Water Pollution Control Facility Upgrades | City of San Jose, California**

Provided electrical, instrumentation and control design and construction support services for improvements to the 167 mgd San Jose-Santa Clara Water Pollution Control Facility, which included sludge and scum collection system upgrade, as well as new 800A motor control center (MCC), instrumentation, Siemens PLC console, and local SCADA interface.

**Nutrient Removal and Wet Weather Flow Management Upgrade and Expansion | City of San Mateo, California**

Electrical engineer during schematic design, final design, bidding, and engineering services during construction of \$400 million in improvements to the San Mateo/Estero Municipal Improvement District (EMID) Wastewater Treatment Plant.

**Sludge Dewatering and Odor Control at Plant No. 1 (Job P1-101) | Orange County Sanitation District, Fountain Valley, California**

Provided electrical, instrumentation, and control design services for new thickening and dewatering facilities at Plant No. 1. Project includes replacing the existing sludge dewatering systems with a new system; incorporating high solids centrifuge technology; replacing odor control systems serving the dewatering, solids storage, and dissolved air floatation thickener (DAFT) areas; and upgrading sludge pumping, sludge cake conveyance, sludge cake pumping, centrate conveyance, chemical handling, foul air ventilation and utility water systems.



**David P. Greenfield, PE (CA)**  
 Mechanical

David has more than 19 years of experience in the design and construction of wastewater treatment plants. He has served as project engineer on more than 20 water and wastewater treatment plant projects.

**SELECT RELEVANT EXPERIENCE**

**Digester Piping Improvements | City of San Mateo, California**

Provided design and engineering services during construction support of digester piping Improvements, which included adding an overflow pipe from Digester #1 to the sludge storage tank, adding foam suppression pump into pump manifold, and adding suction piping manifold for digested sludge pumps (to transfer sludge from digester to sludge storage tank).

**Biogas Treatment System Improvements | Dublin San Ramon Services District, Dublin, California**

Project manager for preliminary engineering, site planning and alternatives analysis, detailed design including temporary outage plans and/or temporary works, preparation of contract documents (plans, specifications and cost estimates), and engineering support services during the bidding and award phase of improvements to the wastewater treatment plant's biogas treatment system to improve operational efficiency, enhance system reliability and operational flexibility, and meet future anticipated biogas production generated from the anaerobic digesters.

**Gas Management Regulatory Assistance | Sacramento Regional County Sanitation District (Regional San), Elk Grove, California**

To support the management of change process required by state and federal regulations, assisted Regional San to develop a basis for design for the digester components at their 181 mgd Sacramento Regional Wastewater Treatment Plant planned to undergo change. Prepared a memo detailing operational parameters for the floating cover digesters.

**Gas Management System Study | Regional San, Elk Grove, California**

Regional San's Sacramento Regional Wastewater Treatment Plant needed improvements to address periodic uncontrolled system venting. Developed a digester gas management system model for the 181 mgd Sacramento Regional Wastewater Treatment Plant was key to the recommendations. Consulted on the AFT Arrow model built to assess the current gas system. Also provided quality assurance/quality control (QA/QC) review of the model.

**Sacramento Regional Wastewater Treatment Plant Service Air and Digester Gas System Modifications for Risk Management and Process Safety Compliance | Regional San, Elk Grove, California**

Provided business case evaluation, preliminary design, final design, bidding, and engineering services during construction for improvements to the digester gas management system at the 181 mgd Sacramento Regional Wastewater

**EDUCATION**

Bachelor of Science,  
 Mechanical  
 Engineering, California  
 Polytechnic State  
 University, San Luis  
 Obispo, California, 2004

**REGISTRATION**

Professional Engineer,  
 Mechanical | California  
 #39098

**HDR TENURE**

4 Years

**INDUSTRY TENURE**

19 Years



Treatment Plant The service air system separation and gas management boiler feed systems needed to be modified to improve system reliability and safety, and reduce covered process areas that are affected by the risk management plan regulations and management of change procedures. The existing service air system was separated into two independent systems, including one that serves the covered process area and one that serves the non-covered process areas, each with their own compressors and related equipment. Evaluated whether it is more economical to remove the gas management system feed to the boilers and instead rely solely on natural gas from Pacific Gas & Electric (PG&E). Evaluated the total costs related to maintaining the gas management system feed to the boiler room versus removing it and relying solely on the use of natural gas.

#### **London Wastewater Treatment Plant Expansion and Upgrade | City of London, Ohio**

Provided predesign, design, and engineering services during construction of upgrades to the 5.8 mgd wastewater treatment plant. Upgrades included new influent pumps, bar screens with screening bagging system, vortex grit removal system, primary clarifiers, aeration basin, secondary clarifiers, gravity belt thickeners, ultraviolet (UV) disinfection, Class A digestion facility, and a digester gas system. As a project engineer, Designed a proprietary Class A system complete with an egg-shaped digester, as well as the digester gas system that accompanied the digester facility. Also designed a hot water system for building heat and process heat. During construction, provided construction services including submittal review, site visits, and change order negotiation.

#### **Energy Recovery | City of Roseville, California**

Design manager for predesign and design of an energy recovery project to beneficially use the digester gas from an expansion to the 12 mgd Pleasant Grove Wastewater Treatment Plant, as well as maximize the quantity of renewable gas and capitalize on available digester capacity. Responsibilities included coordination of disciplines and subcontractors. Also provided process mechanical design for the project.

#### **Digester and Thickener Facilities Upgrade Final Design and Office Engineering During Construction | City of San Jose, California**

The project involves a complete replacement of the low pressure digester gas system and rehabilitation of aging anaerobic digesters, as part of a comprehensive upgrade to the 167 mgd San Jose-Santa Clara Regional Wastewater Facility sludge and biosolids processing facilities. Provided technical expertise in reviewing submittals.

#### **Wastewater Treatment Plant Primary Sedimentation Expansion and Improvements | Dublin San Ramon Services District, Dublin, California**

Provided civil, process, and mechanical preliminary design and final design of primary sedimentation expansion and improvements at the wastewater treatment plant.

#### **Influent Pump Control Improvements | Dublin San Ramon Services District, Dublin, California**

Project manager for revision of the electrical design documents prepared for the primary expansion and improvements project to include installation of new variable frequency drives (VFDs) on the existing influent pumps 1 & 2 in Building H, and installation of local control stations for the existing influent pumps 1 & 2 in Building H. HDR also reviewed submittals and requests for information (RFIs) associated with the influent pump control improvements.



## D. Scott Joslyn, PE (CA)

Operations

Scott has more than 32 years of experience in design, process control, startup, and operation of water and wastewater treatment plants. He has participated in many plant startups that required planning, mechanical inspections, and verification of proper operation of equipment and processes. He is also an experienced writer and trainer in technical projects.

Scott's background and experience as a professional civil engineer, certified Grade V wastewater treatment plant operator, and resident engineer, along with his experience on more than 40 treatment plants, makes him a valuable member to any team, whether the project is in the planning, design, construction, or commissioning phase.

Scott brings a unique owner/operator mindset to his projects due largely to his experience as a municipal operator and wastewater manager. This allows him to provide recommendations for shutdown and startup and minimize impacts to plant operations. In addition, his experience as a resident engineer allows him to coordinate plant operational needs, contractor needs, and contractual requirements to help project get finished, start up, and operate more quickly. Startup plans and method of plant operation (MOPO) documents along with formal and informal training for the operators will assist clients with field testing and construction sequencing that considers the maintenance of plant operations.

### SELECT RELEVANT EXPERIENCE

#### **Biosolids Management and Future Biosolids Master Plan | Sanitary District No. 5 of Marin County, Tiburon, California**

Operations specialist during preparation of biosolids master plan, which identifies specific, executable management strategies for a 10-year horizon, in the context of changing costs, markets, and regulations.

#### **Anaerobic Digester Cleaning | Camarillo Sanitary District, Camarillo, California**

Developed a temporary solids management operating plan (high level) that can be detailed and implemented for the upcoming planned duration of anaerobic digester cleaning, condition assessment, and repair. Also conducted a preliminary Tier 1 condition assessment of the exterior of the two digesters to determine an estimated remaining useful life of five years. Developed recommendations for basic repairs of delaminated concrete, cracks, joints, and exposed rebar that can be performed by the cleaning contractor while on-site.

#### **Digester Rehabilitation Cleaning/Startup | City of Midland, Texas**

Prior to startup, provided emergency support to services to recover digester from acid lock after overheating due to mechanical failure in heating system. Provided startup and operations assistance for rehabilitation of an existing anaerobic digester. The digester was taken out of service for cleaning and replacement of aging components.

### EDUCATION

Bachelor of Science,  
Civil Engineering,  
California State  
Polytechnic University,  
Pomona, 1993

### CERTIFICATIONS

Professional Engineer –  
Civil | California  
#C60929

Wastewater Treatment  
Plant Operator |  
California #WWTPO V-  
9204

Water Treatment Plant  
Operator | California  
#WTO T-3 20696

Water System Operator  
| California #WDO D-2  
15027

### PROFESSIONAL AFFILIATIONS

Water Environment  
Federation,  
Sacramento, 1992-  
Present

### INDUSTRY TENURE

32 Years

### HDR TENURE

8 Years

**Hill Canyon Treatment Plant – Digester 3 Rehabilitation Project (MI 2533) | City of Thousand Oaks, California**

Provided startup consultation regarding processes and tests required to recommission the digester.

**\$33.7 Million Anaerobic Digester Facility | Heartland Biogas, LLC, Greeley, Colorado**

Provided startup and commissioning services of the entire project, and participated in planning of the \$33.7 million anaerobic digestion facility capable of exporting up to 1.5 British Thermal Units (MMBTU) annually, making it the largest anaerobic digester facility in North America. Services during construction that were provided include design modifications, as well as development of commissioning plans by process area, startup plan, performance testing plans, process control spreadsheets, and operations manual.

**\$115 Million Ellis Creek Water Recycling Facility Startup | City of Petaluma, California**

Startup engineer for nutrient removal activated sludge wastewater treatment plant. Developed all startup protocols and standard operating procedures (SOPs), established operating parameters, and provided training. Recommended process controls and chemical dosing strategies to improve operations for regulatory compliance vulnerabilities for the headworks with washer compactor, grit removal, Orbal oxidation ditch, thickening, acid phase digestion, boilers, screw press dewatering, and pond treatment processes.

**Phase 2 Soscol Water Recycling Facility Upgrade Startup/Operations | Napa Sanitation District, Napa, California**

Engineer and support operator responsible for preparing an operations manual, providing 32 hours of training on new processes, reviewing mechanical facilities for startup planning, providing startup assistance, verifying proper operation, conducting performance sampling, and providing process optimization. Processes included a headworks with washer compactor, aerated grit with classifier, primary clarification, activated sludge, anaerobic digestion, dissolved air flotation (DAF) thickening, and belt filter press dewatering. Pond treatment processes included DAF clarification and disinfection.

**Wastewater Treatment Plant Operations and Maintenance | Nevada County Sanitation District, Nevada City, California**

Chief plant operator and operations manager for this special district. Responsible for the operation and maintenance (O&M) of 10 wastewater treatment plants in Western Nevada County. Four have nutrient removal, three have NPDES permits with surface water discharge, and seven are land application. The Lake of the Pines Wastewater Treatment Plant included startup of membrane bioreactor (MBR) facilities. Developed Board of Directors agenda items, budgets, State Revolving Fund (SRF) application with principal forgiveness, engineering solutions to difficult district problems (such as odor control), consolidation of treatment plants, and sanitary sewer management plan (SSMP). Designed and implemented new process controls and chemical dosing strategies to improve operations for regulatory compliance vulnerabilities. Worked with consultants, Regional Water Quality Control Board (RWQCB), and public advisory group. Treatment plants included oxidation ditches, membrane bioreactors (MBRs), packaged trickling filters, tradition biological nutrient removal (BNR) plants, aerobic digesters, dissolved air flotation (DAF) thickening, centrifuge dewatering, and leach fields.

**Regional Wastewater Treatment Facility Startup/Operations | Sewer Authority Mid-Coastside, Half Moon Bay, California**

Engineer responsible for training, startup assistance, and preparation of an operations manual discussing the automation and process control for primary, secondary, and solids handling processes. Solids handling processes included anaerobic digestion and belt filter press sludge dewatering.

**Composting Facility Operations | Las Virgines Municipal Water District, Calabasas, California**

Responsibilities included authorship of eight volumes of operations manuals and standard operating procedures (SOPs) discussing the operation, automation, and process control for anaerobic digestion, biosolids dewatering, and in-vessel municipal solids composting. Delivered 48 hours of process training to plant operators and supervisors. Reviewed contractor supplied

equipment submittals detailing the operation and maintenance of special equipment.

**Soscol Wastewater Treatment Plant Master Plan | Napa Sanitation District, Napa, California**

Project engineer responsible for working with operations staff to determine maximum plant capacity of the biological nutrient removal (BNR) activated sludge and pond plant with dissolved air flotation (DAF) thickening, anaerobic digestion, and belt filter press (BFP) dewatering. Developed lists of improvements for future implementation to improve operations for regulatory compliance vulnerabilities.

**Soscol Water Recycling Facility Digester Gas Holder Replacement | Napa Sanitation District, Napa, California**

Project engineer for the investigation and subsequent replacement design of the digester gas holder. The replacement holder improved the process operation of the digester gas system.

**Phase 3 Mountain House Water Reclamation Facility Expansion | Mountain House Community Services District, Mountain House, California**

Provided independent peer review and startup services for the Phase 3 expansion of the Mountain House Water Reclamation Facility from 3 to 4 mgd. The project included digester improvements.

**Pond Solids Remediation Study | City of Stockton, California**

Conducted a field evaluation and developed two reports. The first report presented a preliminary design for conveying tertiary plant algae float to the anaerobic digestion process to reduce the recycle loading on the pond process.

**Regional Wastewater Treatment Plant Startup/Operations | City of Winston and Green Sanitary District, Winston, Oregon**

Startup engineer responsible for preparing an operations manual, providing 12 hours of training on new processes and startup assistance, and developing project performance standards to meet Oregon Department of Environmental Quality state revolving loan standards. Participated in the startup of and provided specific training on the operation of anaerobic digestion and 1 mgd activated sludge processes. Developed process control

spreadsheets and provided long-term operations assistance.

**East County Bioenergy Project | Delta Diablo, Antioch, California**

Served as the owner's agent on a design-build project to develop additional food waste based loading on existing municipal anaerobic digestion process. Reviewed design-build proposals for reasonable assessment of engineering, financial, and operational considerations of the project, along with risk assessment and mitigation of risks to ensure future successful and profitable operation of process.

**Water Reclamation Plant Electronic Operations and Maintenance (eOM) Manual | City of Livermore, California**

Developed an HTML-based eO&M for the water reclamation plant, which included headworks, odor control, primary treatment, aeration, secondary sedimentation, disinfection of secondary effluent, flocculation and filtration, ultraviolet (UV) disinfection, reclaimed water distribution, sludge thickening, digestion, sludge dewatering, sampling and analysis, and miscellaneous operations.

**Independent Operation and Maintenance Evaluation | City and County of Honolulu, Hawaii**

Completed fast-track evaluation in response to an Environmental Protection Agency (EPA) administrative order. Revisited project to evaluate progress and update recommendations. Treatment plant processes included dissolved air flotation (DAF) clarification, disinfection, and digestion.

**Digester No. 4 | City of Wenatchee, Washington**

Operations specialist during construction of an additional digester to provide redundancy for downstream unit processes (primary clarifier, aeration basins, secondary clarification) to ensure full compliance with the cities discharge permit during times when a digester must be removed from service for maintenance or repairs.

**El Dorado Hills Wastewater Treatment Plant Phase III Expansion | El Dorado Irrigation District, El Dorado Hills, California**

Project engineer on design to double treatment capacity. Specific design responsibilities included



new primary sludge thickening with rotary drum thickener, conversion and expansion to high-solids thermophilic digestion, boiler and heating loops, and upgrade and expansion of belt filter press dewatering.

**\$72.8 Million Little Patuxent Water Reclamation Plant Biosolids Processing Facilities Improvements Construction Manager at Risk (CMAR) | Howard County, Savage, Maryland**

Operations specialist during design and startup of \$72.8 million in biosolids processing facilities improvements. The project was design and constructed into two phases. The first phase of the project included the addition of the anaerobic digestion facilities, including gas storage and conditioning equipment, centrate treatment, solids thickening improvements, odor control improvements, and improvements to the solids storage tanks. The second phase of the project included the heat drying building, heat dryers, gravity thickeners, relocated centrifuges, odor control equipment, site improvements, and demolition of the existing lime stabilization facilities. Provided startup management and advice while training local engineers on means and methods of startup engineering. New polymer systems are provided for thickening and dewatering and polymer dose changes recommended as each process came on line.

**Pleasant Grove Wastewater Treatment Plant Solids Handling | City of Roseville, California**

Designed the gravity belt thickening facility and anaerobic digestion, taking advantage of existing sludge storage, odor treatment, and centrifuge dewatering.

**Anaerobic Digester | City of Santa Fe, New Mexico**

Operations specialist during design and construction of an anaerobic digester facility at the wastewater treatment plant. Improvements included two additional anaerobic digesters and associated appurtenances. This new facility is a fully self-contained facility and in which each digester can operate independently when the other is offline.

**Arlington Water Pollution Control Plant Engineering Program Management Consulting – Phase 1 | Arlington County, Arlington, Virginia**

Operations specialist for the implementation of new \$120 million solids handling processes at the Arlington Water Pollution Control Plant, which include: (1) sludge thickening, screening, and/or pre-dewatering; (2) thermal hydrolysis pretreatment equipment; (3) mesophilic anaerobic digestion systems; (4) dewatering equipment; (5) mitigation of impacts from sidestreams; (6) gas cleaning and combined heat and power generation or gas distribution equipment; (7) auxiliary boiler/steam generation system; (8) electrical power distribution and/or natural gas fuel systems; (9) odor and air emissions control; (10) instrumentation and controls; (11) dewatered biosolids loading facilities; and (12) site preparation and site improvements. A marketable Class A biosolids product and biogas utilization system to clean and make use of methane gas either on- or off-site are also envisioned. Developed and managed a comprehensive program for the engineering, design, construction, maintenance, startup, and operation necessary to add sustainable equipment and systems to effectively recover Arlington County renewable resources, produce a Class A biosolids product, and most efficiently utilize the biogas (the Program).

**Wastewater Treatment Plant Improvements | Town of Erie, Colorado**

Provided startup/commissioning for a new Autothermal Thermophilic Aerobic Digestion (ATAD) facility, with new thickening, dewatering, and solids storage. A Construction Manager At-Risk (CMAR) project delivery was used to build the design.

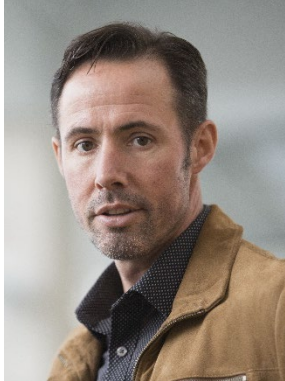

**James T. Keegan**  
Corrosion Inspection

James was hired by HDR in 1993 to open HDR’s Corrosion Laboratory and now serves as the Corrosion and Lab Services Section Manager for HDR’s Corrosion and Condition Assessment Group. In his current role, he manages HDR’s Corrosion Group as well as all operations of HDR’s Corrosion Laboratory. He has overseen the testing of more than 125,000 soil, water, and concrete samples. He has performed failure analyses, soil corrosivity studies, construction acceptance testing, water aggressivity studies, cathodic protection surveys, and direct and indirect condition assessments for all common pipe materials and concrete structures.

**SELECT RELEVANT EXPERIENCE**

**EDUCATION**

Bachelor of Science, Computer Science and Engineering, University of La Verne, 2002

**HDR TENURE**

19 Years

**INDUSTRY TENURE**

22 Years

**As-Needed Corrosion Assessment Services | Inland Empire Utilities Agency District, Chino, California**

The Inland Empire Utilities Agency (IEUA) is a regional wastewater facility in southern California that operates five regional wastewater treatment plants and processes 60 mgd. HDR has been providing as-needed corrosion assessment services for the last five years. Since inception, condition assessments have been conducted on numerous digesters, headworks, wet wells, influent pump stations, grit chambers, diversion structures, primary clarifiers, secondary clarifiers, aeration basins, and various process piping across the five treatment facilities. James served as the project manager on the majority of the task orders to date.

**Corrosion Master Plan | Rainbow Municipal Water District, Fallbrook, California**

Provided an initial overall system survey along with soil corrosivity testing to develop a corrosion master plan, cathodic protection design manual, as well as investigate the root causes for pipe breaks. James is serving as the Contract Manager, Soil Corrosivity Lead, and Project Manager.

**Capital Improvement Program, Support Services for Corrosion Engineer & Corrosion Technician | San Diego County Water Authority, San Diego, California**

HDR provides San Diego County Water Authority with a full-time on-site corrosion technician and one engineering technician. James is the consultant contract and project manager. Corrosion and cathodic protection services provided include:

- Corrosion consultation for materials and coatings.
- Training of agency personnel.
- Conducting an annual cathodic protection and corrosion monitoring survey for more than 51 miles of parallel large diameter tape wrapped steel, cement-mortar coated steel, and pre- stressed concrete cylinder pipe.

- Witnessing and performing construction checkouts.
- Developing corrosion control manual and standard corrosion guide drawings.
- Conducting stray current studies.
- Conducting electromagnetic conductivity surveys.
- Designing cathodic protection.
- Conducting internal pipe inspections.
- Using non-intrusive test methods to locate discontinuous pipe joints in post-tensioned concrete cylinder pipelines.
- Identifying and correcting problematic areas with cathodic protection systems.
- Maintaining the agency's corrosion database.

penetrating radar, and chemical and compressive strength testing of concrete powder and core samples.

**As-Needed Corrosion Engineering Services | Mojave Water Agency, Apple Valley, California**

The Mojave Water Agency is a regional wholesale water provider that serves an area of approximately 4,900 square miles. HDR and James have provided corrosion and condition assessment services to the agency since 1994 with corrosion engineering support for their first major pipeline construction. Services provided under the existing as-needed contract included pipe-to-soil surveys, rectifier troubleshooting, stray current detection and mitigation designs, and design and construction acceptance support for the replacement of sacrificial anode cathodic protection systems. James is the contract and project manager for this project.

**14 Million-Gallon Cistern Condition Assessment | Long Beach Water Department, Long Beach, California**

Long Beach Water District required the inspection of a 14 mgd reinforced concrete cistern during a biennial shutdown. As project manager, James formed the project's testing approach and oversaw data collection and reduction. The inspection consisted of free corrosion potential mapping, surface pH determination, aural inspection, surface



**John E. Koch, PE (ID, IN, WA)**  
 Quality Assurance/Quality Control (QA/QC)

John has more than 53 years of experience in the analysis, equipment selection, design, and construction and commissioning of wastewater treatment facilities. He has served as project manager, project engineer, QA/QC reviewer, technical advisor, or startup specialist on more than 100 wastewater treatment plant projects nationwide. He has extensive experience in mechanical equipment and has designed most of the available dewatering and mixing technologies available for solids.

**SELECT RELEVANT EXPERIENCE**

**EDUCATION**

Bachelor of Science,  
 Civil Engineering,  
 Indiana Institute of  
 Technology, 1968

**REGISTRATIONS**

Professional Engineer |  
 Idaho, #8369  
 Professional Engineer |  
 Indiana #PE60017723  
 Professional Engineer,  
 Civil | Washington  
 #23981

**CERTIFICATION**

Board Certified  
 Environmental Engineer

**HDR TENURE**

35 Years

**INDUSTRY TENURE**

53 Years

**McDowell Creek Phase II Reliability Improvements | Charlotte Water, Charlotte, North Carolina**

Performed a condition assessment of Digesters No. 1 and 2, digester control building, and Treatment Trains No. 1 and 2, and subsequently served as QA/QC review during design of rehabilitation improvements that included replacing floating steel covers with concrete domes, replacing of mixing system with internal draft tube mixers, replacement of digester gas accessories, new internal piping inside digester, repair of digester concrete cracks and concrete, calcium aluminate overlay on walls and floor, and improvements to the digester control building, which included replacement of the pressure level elements, digester gas flow meters, electrical breaker box, guardrail, exhaust fans, built-up roofing, makeup air handler, mag meter to drying beds, digester gas sediment traps, methane analyzers, feed digester valve actuators, and sump pumps. HDR rehabilitated Digesters No. 1 and No. 2 and put them back into service, which allowed Digester No. 5 to be cleaned and inspected.

**Tomahawk Creek Wastewater Treatment Facility Improvements | Johnson County Wastewater, Leawood, Kansas**

QA/QC reviewer during design of \$230 million in modifications and improvements to the 19 mgd Tomahawk Creek Wastewater Treatment Facility, which included modifications to the existing digester complex. The mechanical systems associated with the digestion process (e.g., pumps, mixers, boilers) were old and beyond repair. The tank covers and concrete structures had corrosion damage, requiring replacement of the covers and repair of sections of the tank feed/overflow boxes.

**Wastewater Facility Improvements | City of Gillette, Wyoming**

QA/QC reviewer during design of improvements at the wastewater treatment plant, which included new septage receiving facility, primary digester cover replacement, ultraviolet (UV) disinfection, dewatering, waste activated sludge (WAS) thickening, underground piping and valves, electrical campus and building power, yard waste/compost/roads, and miscellaneous mechanical work. Digester improvements included waste gas burner replacement, gas mixing blowers, relocation of blowers, new electrical for blowers, new lighting, and replacement of boiler unit, valves, pumps, and HVAC in digester/energy buildings.



### **Digester and Dewatering Improvements | City of Boise, Idaho**

Provided QA/QC during design of improvements to allow parallel digester flow operation for Digesters 1 and 2 to allow Digester 3 to be removed from service for assessing its condition and cleaning. To clean Digester No.3, it was necessary to design and construct a drying bed area to allow for temporary storage of digested solids at the bottom of the digester cone area that are too thick to be dewatered through the existing belt filter press operation. Operation of the digestion process was changed to a 50/50 parallel flow operation to Digesters No. 1 and No. 2, allowing Digester No. 3 to be taken offline to complete the cleaning and condition assessment work effort. The digested solids from Digester No. 3 were cleaned out and were pumped and stored in the drying beds as part of the digester cleaning.

### **Digester/Clarifier Coating | City of Coeur d'Alene, Idaho**

Provided QA/QC during condition assessment and design of the interior coating of Digester No. 4 and a new/rehabilitated cover for Digester No. 2.

### **Phase 5B Advanced Wastewater Treatment Facility | City of Coeur D'Alene, Idaho**

Provided QA/QC review during design of Phase 5B improvements, which included a new anaerobic digester, a digester support building, a new gas handling building, and new solids thickening facilities with SCADA control upgrades.

### **Phase 4A Wastewater Treatment Plant | City of Coeur D'Alene, Idaho**

QA/QC reviewer during \$28 million Phase 4 upgrade and expansion of the wastewater treatment plant, which included the addition of anaerobic digesters.

### **Wastewater Treatment Plant Improvements and Expansion | City of Fremont, Nebraska**

Provided QA/QC review during design of three separate wastewater treatment plant improvement projects to address the projected increases in flows and loads with consideration given to future nutrient removal requirements and associated anticipated improvements or plant modifications. Improvements included an additional egg digester to address

increased solids loadings, and state-of-the-art biogas conditioning system.

### **Missouri River Water Resource Recovery Facility Digester Cover Repair | City of Omaha, Nebraska**

The Missouri River Wastewater Treatment Plant's Digester No. 4 was out of service, due to cover failure. The city needed to put the unit back in service on a temporary basis either as a floating cover or as a sludge holding tank. This option was essential in a response to an emergency contract that is funded by an emergency purchase order. The project consisted of two main tasks. HDR performed a structural analysis of the cover to determine if the cover could be used for either of the desired functions identified above. The analysis included potential provisions to prevent the cover from filling with biological foam/sludge if the tank is used as a floating cover. The second task was the authorization to precede with initial design items to prepare documents to allow early bidding of the cover for Digester No. 1. Once the second task began, HDR was verbally directed not to proceed further with this task. HDR then began to assist the city in potentially supporting Digester Cover No. 1 which recently had experienced elements of failure. Provided QA/QC during design of improvements.

### **Water Reclamation Facility Phase 1 Expansion and Improvements | City of Bozeman, Montana**

Provided QA/QC review during design of Phase 1 improvements to the water reclamation facility, which included one new anaerobic digester and a new digester control building.

### **Picnic Point Wastewater Treatment Plant Upgrade | Alderwood Water & Wastewater District, Lynnwood, Washington**

Provided predesign of improvements to the existing Picnic Point Wastewater Treatment Plant, which included digester decant pump upgrades.

### **Applied Research Digester | City of Philadelphia Water Department, Pennsylvania**

Assisted with development of an alternatives evaluation report to recommend a digester mixing technology. This evaluation also included preliminary planning for future co-digestion piloting at one of the city's facilities to determine the cost

and potential impacts of feeding food-waste to digesters to increase biogas production.

**Digester Upgrade | City of Silverton, Oregon**

Designed digester upgrades, which included new covers and mixing system, and all new mechanical equipment.

**Easterly Wastewater Treatment Plant Upgrade | City of Vacaville, California**

Provided QA/QC review during design of improvements for the Easterly Wastewater Treatment Plant, which included anaerobic digester facility upgrades.

**Digester No. 4 | City of Wenatchee, Washington**

QA/QC reviewer during design of an additional digester to provide redundancy for downstream unit processes (primary clarifier, aeration basins, and secondary clarification), and ensure full compliance with the cities discharge permit during times when a digester must be removed from service for maintenance (aka cleaning) or repairs.

**Primary Digesters 1-3 Rehabilitation | City of Westminster, Colorado**

Provided QA/QC review of rehabilitation improvements to the Big Dry Creek Wastewater Treatment Facility Primary Digesters 1-3. These digesters were constructed more than 30 years ago and were in need of rehabilitation. The interior liner had deteriorated and needed to be replaced, cracking in the roof structure was impacting structural integrity, and the mixing system required replacement.

**Wastewater Treatment Plant Expansion | City of Yuba City, California**

Provided QA/QC review during design of improvements to expand the wastewater treatment plant from 7 to 9 mgd. Improvements included anaerobic digestion system upgrades.

**Atlantic Treatment Plant Cambi Thermal Hydrolysis Process (THP) and Fats, Oils, and Grease (FOG) Receiving Station | Hampton Roads Sanitation District, Virginia Beach, Virginia**

Assisted with design of improvements to implement a FOG station, improve biosolids cake dewaterability, and produce a Class A production

through a Cambi B6 Thermal Hydrolysis Process (CambiTHP) System. Collaborated to develop an alternative digester cleaning process that significantly reduced project schedule and reduced impacts to digester operations during construction.

**Nelson Middle Basin Digester | Johnson County Wastewater, Mission, Kansas**

QA/QC review for design of a digester.

**Irwin Creek Digester Improvements | Charlotte-Mecklenburg Utilities, Charlotte, North Carolina**

Provided QA/QC review during design of improvements to convert four of six floating-cover pump-mixed digesters to fixed-cover, high-rate, mechanically mixed anaerobic digesters at the 15 mgd Irwin Creek Facility. The other two were converted to biosolids storage tanks with floating hydroseal-type covers to contain odors and allow for fluctuating liquid levels and digester gas storage. The project also included installation of fixed concrete digester roofs and digester mixers; sludge recirculation pumps; hot water boilers; heat exchangers; sludge grinders; a digester gas scrubber; and digester gas equipment.

**Northside Wastewater Treatment Plant Digester Modifications | City of Tulsa, Oklahoma**

Technical quality control lead for the predesign of improvements to the 42 mgd digestion pasteurization system.

**Regional Wastewater Treatment Plant Digester Equipment Purchase | City of Yakima, Washington**

Project manager for preparation of plans and specification for the prepurchase of digester gasholder covers and digester mixers. Gasholder covers were for the three 40-foot-diameter secondary digesters. This was the first flexible membrane digester gasholder covers for a triplex system. The digester mixers were top mounted slow speed mechanical mixers for one 70-foot diameter and two 45-foot diameter primary digesters.

**Durham Advanced Wastewater Treatment Plant, Phase II-A Improvements | Clean Water Service, Tigard, Oregon**

Design and construction manager for approximately \$35 million in improvements to solids handling,

chemical conditioning systems, and new controls and piping for existing effluent filters. Replaced sludge incineration with four 700,000-gallon mechanically-mixed anaerobic digesters, three thickening centrifuges, and a new sludge conditioning and storage system using two hydraulically actuated piston pumps and two sludge storage silos providing 5,400 cf of storage capacity. Installed 800-hp dual-fueled engine co-generation system that uses digester or natural gas. Directed a team of 13 engineers and construction management personnel working with as many as seven contractors on site at any one time. Also involved in managing a simultaneous project to program and install new programmable logic controller (PLC) and SCADA controls system.

**Pala Casino Wastewater Treatment Plant Design-Build | Pala Casino, Pala, California**

Technical adviser during design of improvements to provide a tertiary treatment plant with 0.6 mgd capacity, expandable to 1.2 mgd. Facility included digester.

**Wastewater Treatment Plant Upgrade | City of Mount Vernon, Washington**

Design lead for predesign effort to upgrade the activated sludge wastewater treatment plant from 12 mgd to an ultimate capacity of 50 mgd. Improvements included new digesters and new biogas management system.

**Phase II Dos Rios Digester Mixing and System Enhancements | San Antonio Water System, San Antonio, Texas**

Provided QA/QC review during design of rehabilitation improvements for three existing anaerobic digesters, which included replacing the existing digester mixing system, upgrading the electrical components associated with the three digesters, structurally repairing the prestressed concrete digester/sludge holding tank's dome liner and foundation, and replacing the existing waste gas flare system. Existing sludge valves were replaced with new isolation valves. Rehabilitation of the digester mixing system consisted of replacing the existing draft tube mixers with a more effective and efficient pump nozzle mixing system.



**Theodore H. Kontonickas, PE (CA)**  
Project Engineer

Ted is a process and mechanical design engineer with more than 31 years of experience in the analysis and design of HVAC, odor control, plumbing, and process systems in the areas of water and wastewater.

**SELECT RELEVANT EXPERIENCE**

**Digester Piping Improvements | City of San Mateo, California**

Project manager for final design, bidding, and engineering services during construction of digester piping Improvements, which included adding an overflow pipe from Digester #1 to the sludge storage tank, adding foam suppression pump into pump manifold, and adding suction piping manifold for digested sludge pumps (to transfer sludge from digester to sludge storage tank). Also served as project manager for subsequent design of improvements to replace selected exposed and buried sludge piping between Digester No. 1, Digester No. 2, and the Digester Control Building. The existing digester piping was impacted by struvite forming, causing reduced flow and increased operations and maintenance (O&M). The replacement with smooth wall pipes will prevent future struvite deposition and allow for easier cleaning in the event of struvite deposition.

**Digester No. 1 Mixing System at the City’s Wastewater Treatment Facility | City of Watsonville, California**

Project manager for design, bidding, and engineering services for the addition of a mixing system for Digester No. 1 at the wastewater treatment facility. Improvements also included repair of cracks and addition of Enduraflex coating for the Digester No. 1 roof coating, as well as additional piping and valves to feed Digester No. 2 from the existing fats, oils, and grease (FOG) system or from a future FOG facility.

**Digester Mixing and FOG Receiving Station Improvements | City of Watsonville, California**

Project manager for design of improvements to replace the existing gas mixing system with a high-efficiency pump mixing system to improve mixing efficiency and expand the FOG receiving facilities. The goals of the project are to optimize mixing of the secondary digester to be able to feed FOG and/or food waste slurries to the secondary digester, produce more methane gas for cogeneration, and to increase revenue as a result of additional tipping fees. Improvements to the FOG receiving station included an additional 10,000 gallon storage tank, piping and necessary ancillary equipment.

**Digester and Dewatering Improvements | City of Boise City, Idaho**

Assisted with design of the expansion of anaerobic digestion process (adding 4th digester) at West Boise Water Renewal Facility. Developed design and specifications to allow parallel digester flow operation to allow Digester No. 3 to be removed from service for cleaning.

**EDUCATION**

Master of Science, Civil Engineering, California State University, Sacramento, 1994

Bachelor of Science, Mechanical Engineering, California State University, Sacramento, 1990

**REGISTRATION**

Professional Engineer, Mechanical | California #M-029378

**HDR TENURE**

31 Years

**INDUSTRY TENURE**

31 Years



**Anaerobic Digester | City of Turlock, California**

Assistant project manager and lead project engineer for design and construction of a new anaerobic digester, digester control building, sludge pumping recirculation mixing system, and a hot water pump recirculation system.

**Anaerobic Digester | City of Atwater, California**

Designed modifications to an anaerobic digester for the 6 mgd wastewater treatment plant, which included demolition of the existing gas compressor mixing system, modification to the sludge supply piping, and new pump mixing system. Two new holes cored into the existing digester for supply and return piping to the mixing pump.

**Anaerobic Digester Facility Improvements | Minden-Gardnerville Sanitation District, Minden, Nevada**

Provided construction engineering services for anaerobic digester facility improvements, which included: (1) new anaerobic digester; (2) new anaerobic digester control building; (3) new trickling filter feed pumping station to increase peak flow pumping capacity to the trickling filters; (4) rehabilitation of two existing anaerobic digesters to correct deficiencies; and (5) a fourth influent pump.

**Anerobic Digester Facility Upgrades for Easterly Wastewater Treatment Plant Tertiary Project | City of Vacaville, California**

Provided design and engineering services during construction of filtration improvements for the Easterly Wastewater Treatment Plant, which included anaerobic digester facility upgrades.

**Silverton Wastewater Treatment Plant Upgrade | City of Silverton, Oregon**

The City of Silverton operates an advanced wastewater treatment facility rated at a maximum monthly flow of 6.6 mgd. Assisted with design of major improvements to the plant, which included a new activated sludge system, refurbishment of two anaerobic digesters with new covers and mixing system, new digester control and biogas buildings, aeration system, addition of a third effluent to increase capacity for pumping to the Oregon Garden, all new mechanical equipment for solids handling facility, grit cyclone and classifier replacement, and refurbishment of the solids side-

stream recycled pumping station with submersible pumps.

**Digester No. 4 | City of Wenatchee, Washington**

Provided design and engineering services during construction support for additional of a new digester at the wastewater treatment plant to provide redundancy for downstream unit processes (primary clarifier, aeration basins, secondary clarification) and ensure full compliance with the Cities discharge permit during times when a digester must be removed from service for maintenance or repairs.

**Sludge Processing System for Phase 2 Deer Creek Wastewater Treatment Plant Upgrade | El Dorado Irrigation District, Placerville, California**

Designed sludge processing system for Deer Creek Wastewater Treatment Plant. System modifications included the conversion of aeration basins into aerobic digesters, and conversion of a clarifier into a sludge holding tank. Sludge pumps were added and piping and valve modifications were designed.

**El Dorado Hills Wastewater Treatment Plant Phase II-B Improvements | El Dorado Irrigation District, El Dorado Hills, California**

Provided design and engineering services during construction of Phase II-B improvements to the El Dorado Hills Wastewater Treatment Plant, including new dissolved oxygen control system, new blower for aeration system building enclosures, new digester gas scrubber, and sludge storage tank conversion.

**Biogas Feasibility Assessment | Sacramento Regional County Sanitation District, Elk Grove, California**

Assisted with developing the commodity agreement extension terms, as well as evaluating potential alternatives to extending the commodity agreement under updated terms, which included onsite generation of power for use at Sacramento Regional Wastewater Treatment Plant, upgrading digester gas to pipeline quality for sale to others, and conversion of digester gas into a transportation fuel for sale to others.

**Phase 5B Wastewater Treatment Plant Improvements | City of Coeur d'Alene, Idaho**

Provided HVAC, plumbing, and hydronic system design and engineering services during construction for Phase 5B improvements to the wastewater treatment plant, which included a new anaerobic digester, digester control building, biogas control building, utility corridor, administration/laboratory, and collections maintenance garage, hot water loop system, steam boiler relocation.

**Sacramento Regional Wastewater Treatment Plant Service Air and Digester Gas System Modifications for Risk Management and Process Safety Compliance | Regional San, Elk Grove, California**

Project manager for business case evaluation, preliminary design, final design, bidding, and engineering services during construction for improvements to the digester gas management system at the 181 mgd Sacramento Regional Wastewater Treatment Plant. The service air system separation and gas management boiler feed systems needed to be modified to improve system reliability and safety, and reduce covered process areas that are affected by the risk management plan regulations and management of change procedures. The existing service air system was separated into two independent systems, including one that serves the covered process area and one that serves the non-covered process areas, each with their own compressors and related equipment. Evaluated whether it is more economical to remove the gas management system feed to the boilers and instead rely solely on natural gas from Pacific Gas & Electric (PG&E). Evaluated the total costs related to maintaining the gas management system feed to the boiler room versus removing it and relying solely on the use of natural gas.

**Wastewater Treatment Plant Expansion | City of Yuba City, California**

Served as assistant project manager and provided civil, process, mechanical, and odor control design of improvements to expand the wastewater treatment plant from 7 to 9 mgd. Improvements included new headworks with influent pumping and screening, pure oxygen activated sludge system modifications, concrete renovation of the oxygen and chlorine contact basins, plant effluent discharge

pipings modifications, additional reclaimed water pumping system, new cogeneration system utilizing microturbines, anaerobic digestion system upgrades, biosolids management improvements, biofilter odor control, new buildings, miscellaneous site work (including paving), miscellaneous hydraulic improvements, plant-wide electrical system improvements, and plant wide landscaping. Buildings included a new 5,000-square-foot administration building that features offices, conference room, and plant control activities areas; conversion of the existing administration building to a laboratory, new maintenance building, and new maintenance storage building.

**Phase 1 Water Reclamation Facility Expansion/Improvements | City of Bozeman, Montana**

Provided HVAC, plumbing, and hydronic system design and engineering services during construction for \$53 million improvements to the 13 mgd water reclamation facility to meet to needs of the rapidly growing community and regulatory restrictions. Improvements included solids digestion and dewatering.

**Easterly Wastewater Treatment Plant Solids Handling and Gas Utilization Analysis | City of Vacaville, California**

Conducted an analysis of the anaerobic digestion system, gas utilization, and cogeneration systems at Easterly Wastewater Treatment Plant. Alternatives that were evaluated included: (1) refurbishing the gas handling system and placing the cogeneration engine in service; (2) anaerobic digestion heating system; (3) digester gas storage and cover replacement; (4) extending the heat loop to the administration building for heating; (5) installing an adsorption chiller at the administration building for cooling; (6) enhancing the digester gas production through the addition of FOG (fats, oil, and grease) system; and (7) alternative gas utilization systems, such as using the existing cogeneration engine, new cogeneration engine, fuel cell, and mini turbine. An opinion of the project cost for the most viable alternatives were developed and discussed in a workshop format to enable to city to select which alternative to implement.



**Allan J. Scott**  
Principal-in-Charge

Allan is an information technology project manager, programmer, and analyst with more than 37 years of experience specializing in information technology, asset management, and geographic information systems (GIS) to support water and wastewater utilities. His experience includes performing analyses, assessments, and implementation of information management systems, and developing strategy and planning documents for gap analysis and system improvement. He has experience providing technologies to support asset management, condition assessment and capital planning, long-range capital forecasting, operations and maintenance (O&M) process improvement and technology implementation. In addition, he has performed a wide range of system development and data management functions, including migration of legacy systems to client/server architecture; design, development, and implementation of new data systems; technical management of information systems; and business management of a corporate service center.

**EDUCATION**

Master of Science,  
Geological Sciences,  
University of Nevada,  
Las Vegas, 1988

Bachelor of Science,  
Geoscience, State  
University of New York  
at Buffalo, 1984

**HDR TENURE**

4 Years

**INDUSTRY TENURE**

37 Years

**SELECT RELEVANT EXPERIENCE**

**Collection System Master Plan | Sanitary District No. 5 of Marin County, Tiburon, California**

Project manager for preparation of a collection system master plan, which included: (1) evaluation of pumping station trends, level settings, and hour meters and development of recommendation for enhanced efficiencies; (2) evaluation of system performance, identification of areas of concern as it relates to odor control, and development of recommendations; (3) condition assessment of sewer lift stations and force mains, and development of prioritized rehabilitation/replacement recommendations based on sanitary sewer overflow (SSO) reduction followed by inflow and infiltration reduction potential; and (4) development of a 15-year capital improvement program for recommended sewer capacity improvements and rehabilitation and replacement, as well as cost for recommended improvements.

**Infrastructure Asset Management Plan Update and Program Support | Ross Valley Sanitary District, San Rafael, California**

Project manager for update of the infrastructure asset management plan, a guiding document for scoping and prioritizing future district asset management activities under the Infrastructure Asset Management Program and Inflow and Infiltration (I&I) Reduction Program. Developed a pipe structural reinspection and repair plan to provide a better understanding of pipe defects and their deterioration rates, as well as provide capital planning and future inspection recommendations. Tools and processes were developed to support district staff owned program for performing defect comparison in the future. A report was prepared that included a schedule for inspection and repairs per the cease and desist order, cost for inspection and repairs, and criteria that identifies whether a Grade 5 Pipeline Assessment and Certification Program (PACP) structural defect has deteriorated upon reinspection. Developed a force main condition assessment plan that ranked the district's force mains to determine where limited inspection budgets should be focused, and evaluated condition

assessment technologies to determine which are appropriate for the force main pipelines to be assessed. HDR worked with the selected condition assessment technology vendors and district staff to develop plans for the inspection work and execute the assessment inspection. A condition assessment data results report was prepared after evaluation of the condition assessment work, which included description of the condition assessment technologies implemented, results of the assessments, and recommendations for improvement to the force main pipelines investigated. The manhole assessment included development of a priority manhole rating model in InfoMaster that assigns a risk score to each manhole based on likelihood of failure and consequence of failure factors, and when combined with an inspection condition score based on manhole inspection results, provides a means of prioritizing manholes for rehabilitation, maintenance, and replacement. A rehabilitation logic decision tree and manhole rehabilitation plan was then developed. The project also included hydraulic model update, preparation of an infiltration and flow (I&I) reduction plan, creek crossing risk assessment, and capital planning integration.

**Wastewater Treatment Plant and Field Stations Condition Assessments | South Tahoe Public Utility District, South Lake Tahoe, California**

Project manager for structural, electrical, and corrosion condition assessments for the wastewater treatment plant electrical equipment, wastewater treatment plant pipelines, select wastewater treatment plant structures (filter building, blower building, return activated sludge [RAS] pumping station, emergency pumping station, material storage, repair shops, two garages, two maintenance shops), and water and sewer field stations.

**Information Technology Asset Management Assessment | Sacramento County Regional Sanitation District (Regional San) and Sacramento Area Sewer District, Sacramento, California**

Conducted an evaluation of Regional San's information technology capabilities and practices, and evaluated them against industry asset management best practices. This evaluation included both the Sacramento Regional

Wastewater Treatment Plant and sewer infrastructure. A key component was the evaluation of the district's MAXIMO computerized maintenance management system (CMMS) and how the district was using it for enterprise asset management. Conducted meetings and interviews with district management and staff, and identified the current information technology and geographic information system (GIS) practices, processes, and capabilities, then compare these capabilities with the best asset management-related IT practices in the wastewater industry to determine the optimal improvements for the district. Evaluated the MAXIMO system and provided an assessment of its effective use as well as recommendations and improvements to increase the effectiveness of the district's asset management program. This task was part of the overall strategic asset management program focused on evaluating the district's overall management operations compared to best asset management practices and developing a strategic plan for district improvements.

**EchoWater Project Asset Management Design Database Development | Sacramento Regional County Sanitation District (Regional San), Elk Grove, California**

Developed a data management system that collects and validates asset, parts, operations and maintenance (O&M) data, and equipment specifications and manuals to support the \$1.7 billion EchoWater project. EchoWater encompasses the design and construction of major facility upgrades at the 185 mgd Sacramento Regional Wastewater Treatment Plant. Provided technical guidance and management for development of the system and processes. The asset management design database is used to collect asset and O&M data throughout the design and construction process and deploy these data to Maximo computerized maintenance management system (CMMS) and the electronic data management system (EDM). The database and associated work processes will prepare Regional San to take over all O&M tasks once testing and commissioning have been completed so there is no lapse in required maintenance. This is a multi-year, multi-project effort that is calculated to reduce Regional San's data management costs by more than 50 percent.





2365 Iron Point Road, Suite 300  
Folsom, CA 95630  
916.817.4700

**hdrinc.com**

We practice increased use of sustainable materials and reduction of material use.

© 2022 HDR, Inc., all rights reserved.





# Proposal

Customer/Prospect Number 5509123

SANITARY DISTRICT NO. 5 OF MARIN COUNTY

**Item #2**

Customer Contact: CHAD Email: cbilsborough@sani5.org  
Phone Number: 415 314-3422 Delivery Instr:

Quantity	Part Number	Unit Price	Extended Price
10	XPR3300E UHF 4W 16C UL WITHOUT THE WIFI AND BT CAPABI PACKAGE DETAILS BELOW	862.00	8,620.00
10	MOT CM200D 403-470 25W DIGITAL BASE STATION PACKAGE DETAILS BELOW <i>BC Extended Warranty Coverage 1 Year</i>	679.00 <i>82.00</i>	6,790.00 <i>820.00</i>
1	ASNSL11SM/GTX/M1225 TAL ASTRON POWER SUPPLY W/HOOD FOR CM200D	199.00	199.00
10	G8MI TES LAIRD ANTENNA MAG MOUNT ANTENNA MOUNT FOR CM200D	44.00	440.00
10	QW450 LAIRD UHF MOBILE ANT ANTENNA FOR CM200D	11.36	113.60
9	MOT IGNITION SWITCH CABLE FOR CM200D	18.36	165.24

### Protect your investment now! Purchase an affordable BearCom Extended Warranty!

Quote valid until 04/30/22 Confidential and Proprietary

X \_\_\_\_\_  
Customer Signature

Sub Total	16,327.84
Shipping and Handling	TBD
Tax	TBD
Total	16,327.84

Check with your Bearcom executive for current Motorola financing promotions through LCA

12 Months 1,428.62    24 Months 756.94    36 Months 523.36    48 Months 410.92    60 Months 344.96

Click on the Link to APPLY NOW: <http://mylease.leasecorp.com/bearcom>

ANDREW WILDER  
Account Executive  
[Andrew.Wilder@BearCom.com](mailto:Andrew.Wilder@BearCom.com)

SAN DIEGO/ESCONDIDO Branch Office: 800-338-1949

\*\*FREE PROGRAMMING\*\*



XPR3300E Standard Package Includes:

- Li-ion IMPRES Li-Ion, 2100 mAh IP68 with Belt Clip (PMNN4491\_)
- IMPRES? Single-Unit Charger CEC Compliant (PMPN4174A)
- UHF or VHF Antenna (must select appropriate option)
- 2" Belt Clip (PMLN4651)
- Accessory Dust Cover (0104058J40)
- 5 Year Essential Repair and Software

CM200D Standard Package Includes:

- Standard Microphone (PMMN4090)
- Standard Low Profile Mounting Bracket (RLN6469)
- Standard Power Cable (HKN4137)
- 3 Year Warranty



## MEMORANDUM

May 4, 2022

To: Tony Rubio (Marin SD5)

From: Todd Beecher (BEI)

cc: None

**SUBJECT: Marin Sanitation District No.5 – Plant Main 480V Motor Control Center Modification Recommendations**

---

Tony,

Per the District's request, I visited the plant on March 18, 2022 and met with District Operations and Maintenance personnel to discuss reliability issues that have been experienced with the existing plant main 480-volt motor control center equipment. The District has requested that I provide recommendations for how to address these past reliability issues.

The existing motor control center (MCC) equipment is Eaton Freedom 2100 Series equipment that was manufactured, installed and commissioned in 2012/2013. The equipment is in good visual condition and does not appear to have any issues that require repair. The MCC is configured to accept three (3) power supply sources; 1) Utility (PG&E); 2) On-site 500kW, permanently-mounted diesel engine-driven standby generator; and 3) Portable, temporary standby generator. The MCC line-up consists of a 1600 ampere main bus with an "A Side" bus (supplied from the PG&E source), a "B Side" bus (supplied from either the on-site generator or portable generator) and a bus tie circuit breaker.

The MCC is configured with an automatic power transfer control system which manages automatic opening and closing of the PG&E main breaker, on-site generator breaker and bus tie circuit breaker. The on-site generator breaker and portable generator feeder circuit breaker are mechanically interlocked (i.e. Kirk Key Interlock) to prevent simultaneous closure of the two (2) generator power source circuit breakers.

The system, when working properly, will normally operate with the PG&E breaker and bus tie circuit breaker both in the "closed" position with the on-site generator source circuit breaker in the "open" position (with the portable generator source circuit breaker mechanically locked in the "open" position). Upon sensing PG&E power loss, the system is designed to automatically initiate starting on the on-site generator. Once the



generator is up to rated frequency (speed) and voltage as sensed by the MCC control system, the PG&E breaker is automatically commanded to open followed by a command from the control system to close the on-site generator breaker, thus restoring power to the plant. Once the PG&E source returns, and after a utility source stability timer has expired to verify PG&E source integrity, the on-site generator breaker is commanded to open, followed by automatic closure of the PG&E breaker to restore PG&E power to the plant.

District O&M staff have reported that the automatic transfer control system has been problematic and has not performed reliably. Below are the specific issues that were reported by District staff:

- Upon PG&E power loss, there have been past instances where the automatic transfer control system did not automatically transfer power to the on-site generator due to suspected issues with the automatic transfer control system circuitry and components
- When attempts were made by District staff to “manually” restore power to the plant when the automatic transfer system did not operate properly, permissive interlocks included in the present automatic transfer scheme circuitry did not permit manual closure of the on-site generation sources
- The existing automatic transfer control system operator interface is overly complex and prone to additional long-term costs related to maintenance and personnel training time
- Despite attempts by the District to retain the services of an Eaton technician to resolve the issues with the automatic transfer control system, the problem persists and there is waning confidence in the reliability of the existing system

District O&M staff noted that based on experience, there is a high degree of confidence with automatic transfer switch (ATS) equipment manufactured by Asco and that implementation of an Asco ATS is preferred over the present MCC automatic transfer control system.

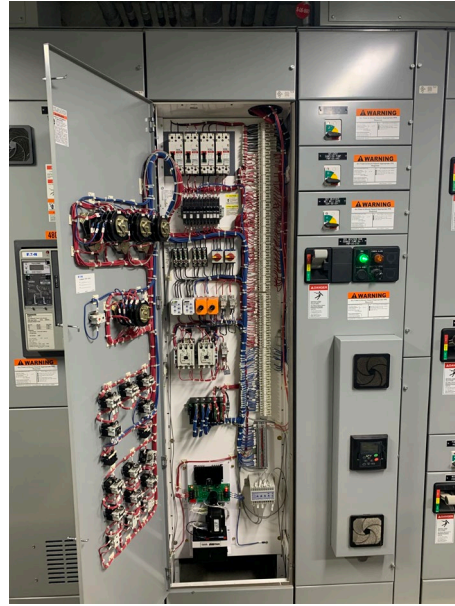
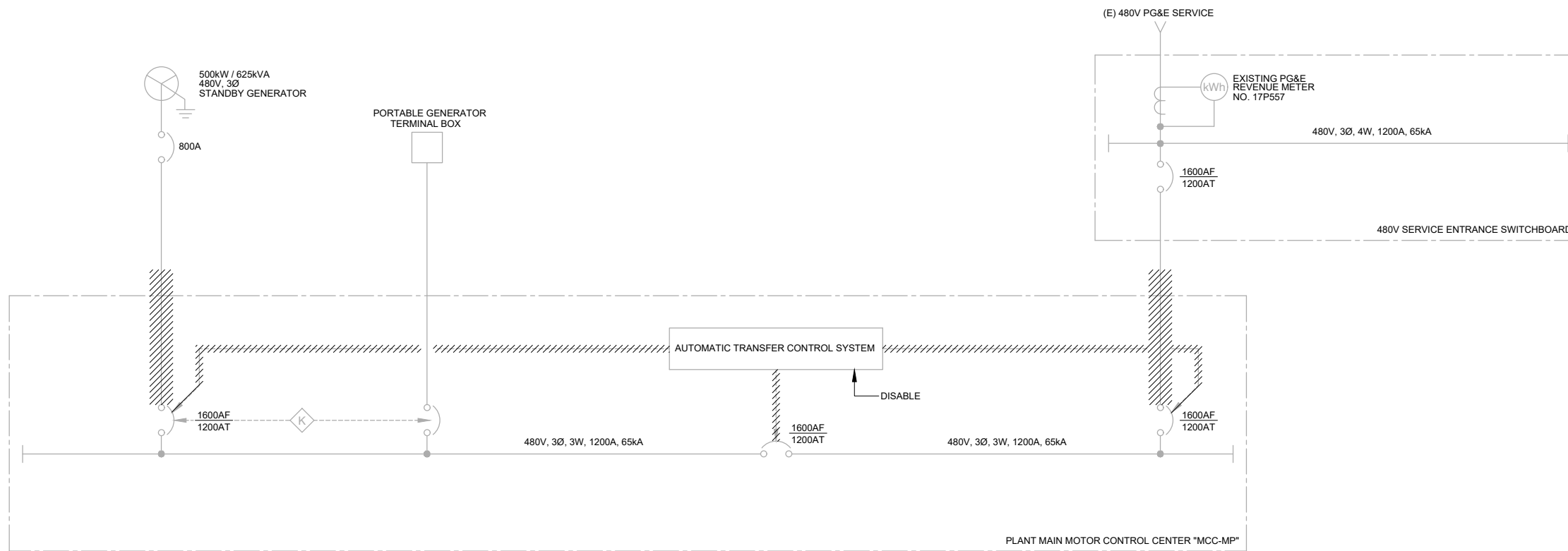

**Figure 1: Existing MCC Automatic Transfer Control System Compartment**

To address the District’s power system reliability concerns, the following system modifications are recommended for consideration:

- Disconnect the existing PG&E supply conductors from the main MCC “A-Side” circuit breaker and modify the existing conductors and conduit presently routed between the 480-volt service entrance switchboard and the main MCC
- Disconnect the existing on-site generator supply conductors from the main MCC “B-Side” circuit breaker and modify the existing conductors and conduit presently routed between the on-site standby generator and the main MCC
- Disable the existing MCC automatic transfer control system to allow for manual operation of the MCC “B-Side” main breaker and bus tie circuit breaker
- Install a new 1200 ampere, 480-volt, 3-phase Asco Series 7000 automatic transfer switch with the following connections:
  - Normal Source: PG&E (derived from the existing service entrance 480-volt switchboard)
  - Emergency Source: On-site Generator (derived from the on-site generator skid-mounted circuit breaker)
  - Load: Connected to the existing main MCC “B Side” on-site generator circuit breaker

A simplified single line diagram is attached (**Figure 2**) which shows this recommended configuration.



**DEMOLITION**

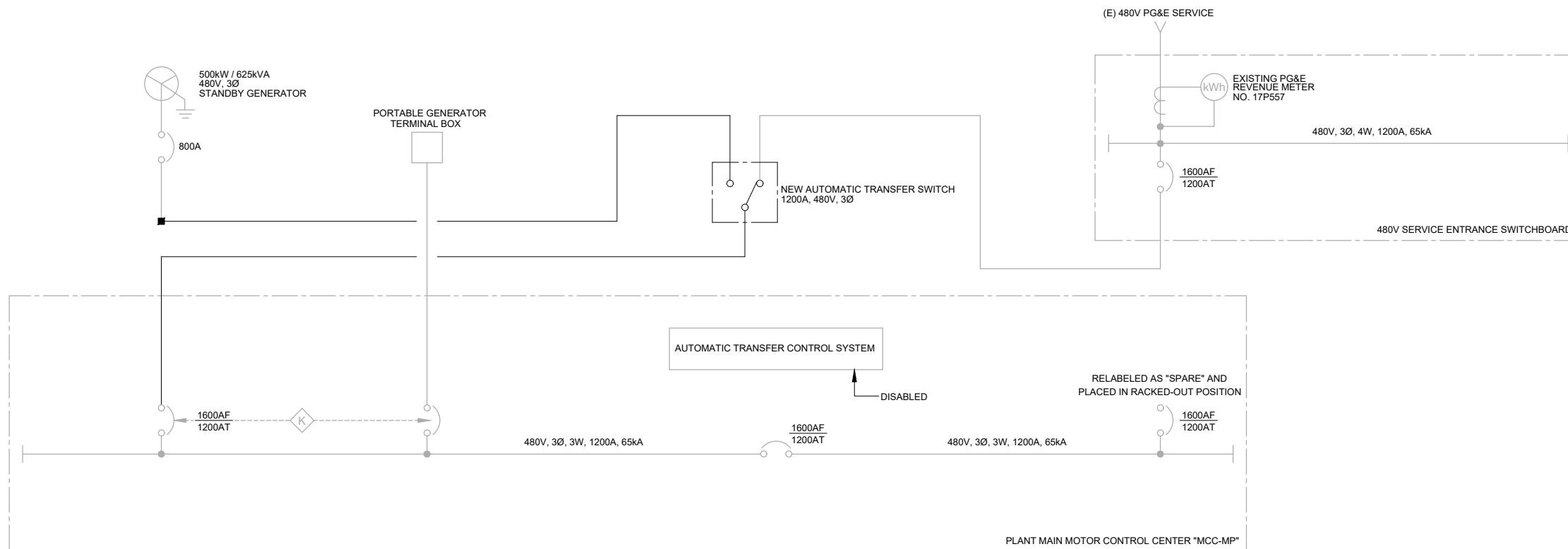

**MODIFICATIONS**

**LEGEND:**  
 // DISCONNECT AND REMOVE

NO.	DATE	BY	REVISIONS

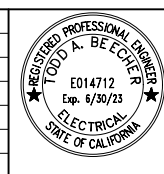

SD5 PROJECT NO.:	xxxxxxx
DESIGN BY:	TB
DRAWN BY:	BEI
CHECKED BY:	xxx
DRAWING DATE:	MAY 2022



**MARIN SANITATION DISTRICT NO.5  
 MAIN POWER DISTRIBUTION  
 SYSTEM MODIFICATIONS**



**ELECTRICAL**

**MARIN SANITATION DISTRICT NO.5 MAIN SINGLE  
 LINE DIAGRAMS - DEMOLITION AND MODIFICATIONS**

**VERIFY SCALES**  
 BAR IS ONE INCH ON ORIGINAL DRAWING  
 0 1"  
 IF NOT ONE INCH ON THIS SHEET, ADJUST SCALES ACCORDINGLY

PROJECT NO. XXXXXX  
 DRAWING NO. FIG 2  
 SHEET NO. 1 OF 1

The new Asco ATS shall be connected to provide the automatic start signal to the on-site standby generator.

Disabling of the existing MCC automatic transfer control scheme to allow implementation of the new Asco ATS scheme will require modifications to each main and bus tie circuit breaker trip and close circuitry. It is recommended that this work be performed by a specialty contractor that has a thorough understanding of switchgear equipment and can demonstrate an acceptable level of experience and competency to perform this work.

After the existing MCC automatic transfer control devices and connections have been disabled, it is recommended that the District consider retaining the devices within the MCC for a time period to ensure that the implemented Asco ATS scheme has demonstrated reliable operation during future PG&E unforeseen outages. Once the Asco ATS has proven to be reliable, the District may want to consider eliminating the existing main MCC automatic transfer control system components to avoid misleading staff that it is “still working” when it is actually completely disabled.

During a recent site visit, a potential location for the new Asco ATS was noted as indicated in **Figure 3** below. Benefits to utilizing this location are its proximity to both the 480-volt service entrance switchboard and the main MCC equipment, thus minimizing the amount of main feeder conduit and conductor modification work required. The downside to selecting this location, however, is that the existing server equipment cabinet will need to be relocated to make space for the new ATS:



**Figure 3: Possible Location for New Asco ATS in Electrical Room**



Attached are hand markups of the existing main MCC shop drawings that were provided by the District. These markups are intended to provide an overview the work that will likely be required to disable the existing automatic transfer control scheme. These markups should not be considered comprehensive but rather as a general illustration of the scope of system disabling. The specialty contractor that is ultimately retained by the District to perform this work should be given a complete set of existing main MCC shop drawings so that the contractor can field-verify the actual installed system and provide a complete set of shop drawing hand markups which reflect their proposed scope of system disabling work.

The estimated installed construction cost for performing the work described herein is as follows:

▪ Existing Automatic Transfer Control System Disabling:	\$10,000
▪ Asco 1200*** ampere ATS:	\$60,000
▪ Existing Conduit and Conductor Modifications:	\$30,000
▪ Testing, Start-up and Commissioning:	\$5,000
<i>Subtotal (Labor and Materials):</i>	<u>\$105,000</u>
Contractor Overhead and Profit (25% of above subtotal):	\$26,250
<b>Total Estimated Construction Cost:</b>	<b>\$131,250</b>

\*\*\* 1200 ampere rating selected to match service switchboard bus rating

Please feel free to contact me if you require any additional information regarding this work. Thank you.

Todd Beecher, P.E.  
Beecher Engineering, Inc.

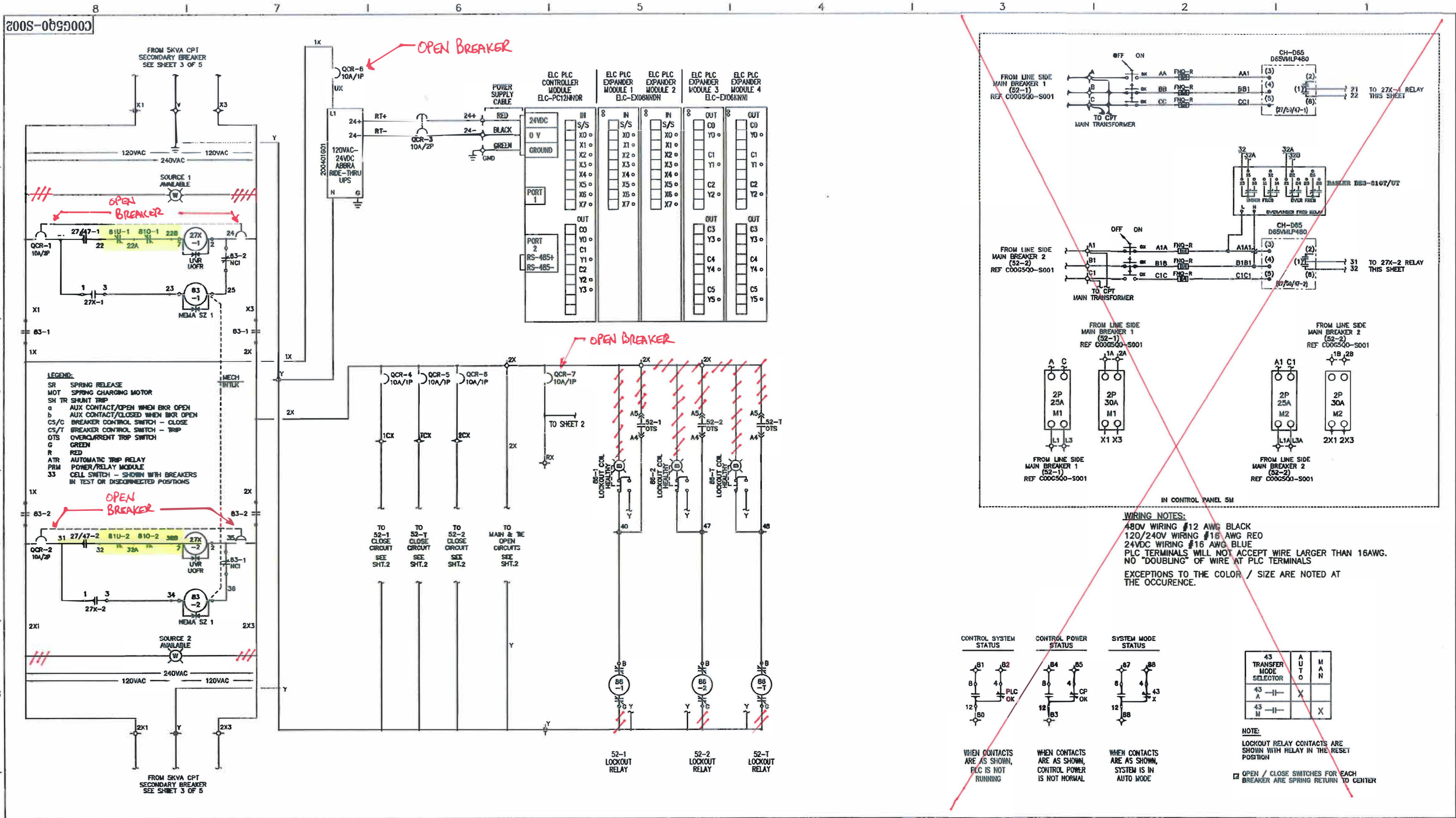

1	REVISION
2	REVISED TO ADD MISSING TERM BLK POINTS DLA 12/15/12
3	REVISED TO ADD SAFETY INTELLOCKS DLA 12/22/12
4	REVISED TO ADD WIRES TO ELC CONT MOD DLA 1/9/13
5	REVISED TO CORRECT FOR PROPER OPERATION DLA 1/18/13
6	REVISED TO ADD UVR WIRING AT A7 & A8 DLA 1/21/13
7	REVISED SEQ. OPR. AEH 1/31/13
8	REVISED PER CUST. COMMENTS JJP 4/18/13
9	REVISED TO CORRECT 81U/O INTLK STATE JJP 4/18/13
10	REVISED TO CORRECT 81U/O INTLK STATE AEH 4/30/13

**WARNING 1**  
 NO MODIFICATIONS / ALTERATIONS OF ANY KIND ARE TO MADE TO THE WIRING WITHOUT CONSULTING ENGINEERING. FUNCTIONALITY OF THE PLC PROGRAM WILL BE COMPROMISED IF THE WIRING HAS BEEN ALTERED.

DFTR	D. ALLNUTT	DATE	12/7/12	THE INFORMATION ON THIS DOCUMENT WAS CREATED BY EATON CORPORATION. IT WAS DISCLOSED IN CONFIDENCE AND IS ONLY TO BE USED FOR THE PURPOSE WHICH IT WAS SUPPLIED.	
APPD		DATE		TITLE MAIN-TIE-MAIN AUTO THROVER	
APPD		DATE		TYPE	FREEDOM 2100 SCHEMATIC
FEDERAL ID NO	PRODUCT CODE	REVISION	DWG SIZE	G.O.	SHEET
	CF	10	B	PSC12420L	1 OF 5



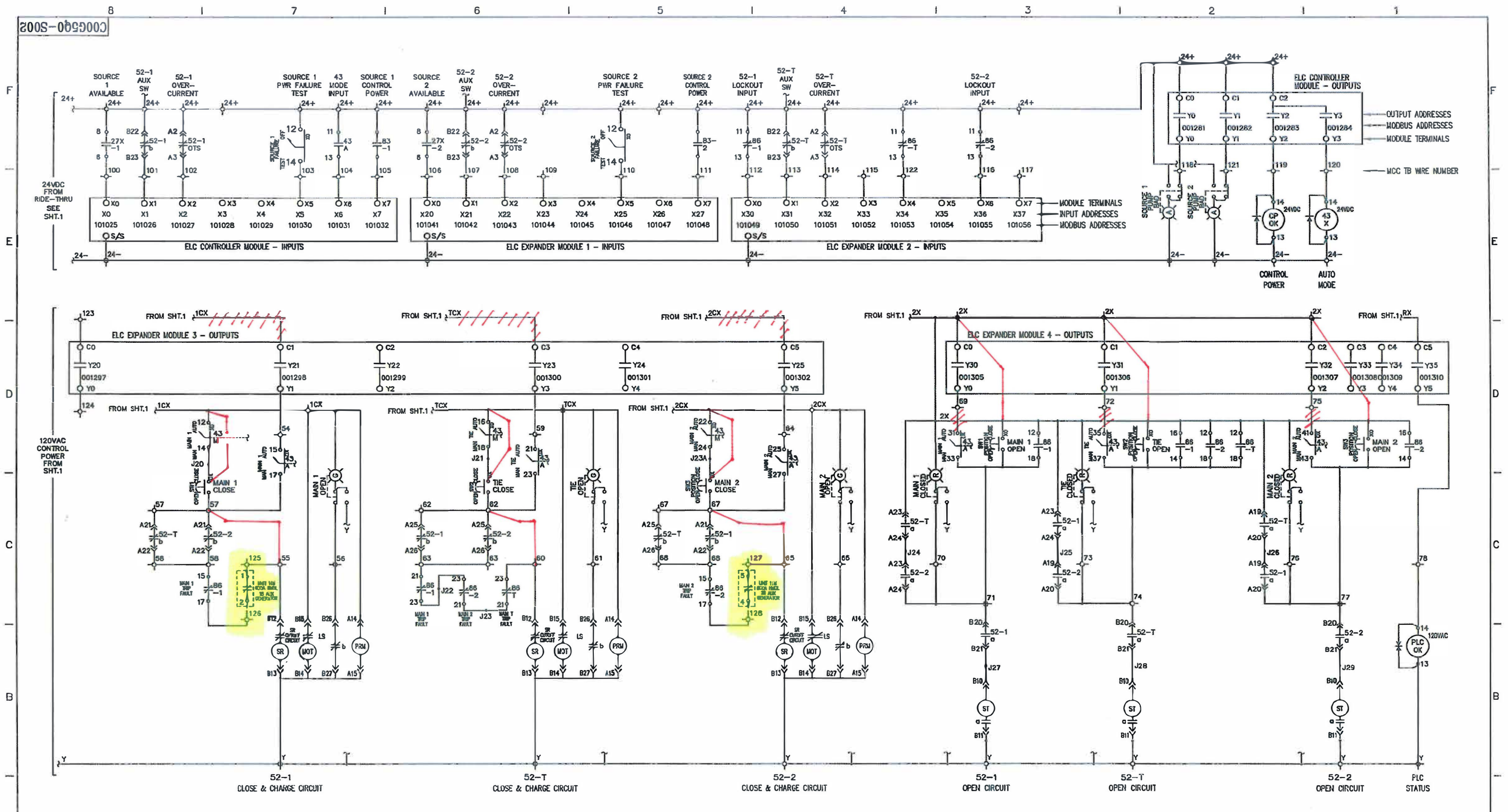

REVISION	DATE	BY
1		
2		
3		
4		
5		
6		
7		
8		
9		
10		

**WARNING 1**  
 NO MODIFICATIONS / ALTERATIONS  
 OF ANY KIND ARE TO BE MADE TO THE WIRING  
 WITHOUT CONSULTING ENGINEERING  
 FUNCTIONALITY OF THE PLC PROGRAM  
 WILL BE COMPROMISED IF THE WIRING  
 HAS BEEN ALTERED.

DFTR D. ALLNUTT	DATE 12/7/12	THE INFORMATION ON THIS DOCUMENT WAS CREATED BY EATON CORPORATION IT WAS DISCLOSED IN CONFIDENCE AND IS ONLY TO BE USED FOR THE PURPOSE WHICH IT WAS SUPPLIED.	
APPD	DATE	TITLE MAIN-TIE-MAIN AUTO THROWOVER	
APPD	DATE	TYPE FREEDOM 2100	SCHEMATIC
FEDERAL ID NO CF	PRODUCT CODE CF	REVISION 10	DWG SIZE B
G.O. PSC12420L	DWG C00G5Q0-S002	SHEET 2 OF 5	